



Pushing Performance

HARTING Connectors DIN 41 612



Type	Termination									
	Solder termination	Reflow soldering (SMC)	Solder lug connection	Press-in connection	Crimp connection	Wire wrap connection	IDC connection	Faston connection	Cage clamp connection	
DIN Signal	B	Page 01.11	Page 01.11							
		Pages 01.12 f	Pages 01.12 f	Pages 01.12 f	Pages 01.12 f	Page 01.15	Pages 01.12 f	Page 01.14		
	2B	Page 01.16	Page 01.16							
		Page 01.17	Page 01.17		Page 01.17		Page 01.17			
	3B	Page 01.18	Page 01.18							
		Page 01.19	Page 01.19		Page 01.19					
	C	Pages 01.20 f	Pages 01.20 f							
		Pages 01.22 f	Pages 01.22 f	Page 01.25	Page 01.24	Page 01.27	Page 01.25	Page 01.26		
	2C	Pages 01.28 f	Pages 01.28 f							
		Pages 01.30 f	Pages 01.30 f	Pages 01.30 f	Pages 01.30 f	Page 01.27	Pages 01.30 f			
	3C	Pages 01.32 f	Pages 01.32 f							
		Pages 01.34 f	Pages 01.34 f		Pages 01.34 f	Page 01.34				
	M	Page 01.41								
		Page 01.42			Page 01.42					
	M-flat	Page 01.43			Page 01.43					
	M invers	Pages 01.44 f			Pages 01.44 f		Pages 01.44 f			
	R	Pages 01.46 f	Pages 01.46 f		Pages 01.46 f		Pages 01.46 f			
		Page 01.49	Page 01.49							
	R (HE 11)	Page 01.50					Page 01.50			
		Page 01.51								
RM				Page 01.48						
Q	Page 01.52			Page 01.52		Page 01.52				
	Page 01.56									
2Q	Page 01.53			Page 01.53		Page 01.53				
	Page 01.56									
2R	Pages 01.54 f	Pages 01.54 f		Pages 01.54 f		Pages 01.54 f				
	Page 01.56									
2R	Page 02.11	Page 02.11								
	Page 02.14			Pages 02.12 f	Page 02.15					
D	Page 03.11	Page 03.11								
	Pages 03.12 f		Page 03.12		Pages 03.14, 03.23	Page 03.12				
E	Page 03.15	Page 03.15								
	Page 03.18		Page 03.18	Page 03.18	Pages 03.17, 03.23	Page 03.18				
I	Page 03.16									
F	Page 03.27	Page 03.27								
	Pages 03.32, 03.34 f		Page 03.33	Page 03.34	Page 03.31	Page 03.33				
U						Page 03.30				
I	Page 03.28				Page 03.29	Page 03.28				
					Page 03.37					
F9					Page 03.37					
FM	Page 03.38				Page 03.38					
	Page 03.39				Page 03.39	Page 03.39				
2F					Page 03.42					
U						Page 03.41				
I					Page 03.40					
	Page 04.11							Page 04.11		
H15	Page 04.14			Page 04.15				Page 04.12	Page 04.13	
	Page 04.16							Page 04.16		
H16										
H 3	Page 04.17									
	Page 04.17									
MH 24 + 7	Page 04.22							Page 04.22		
	Page 04.23				Page 04.23	Page 04.23				
MH 21 + 5	Page 04.24									
	Page 04.25									

■ male

□ female

■ Interface connector

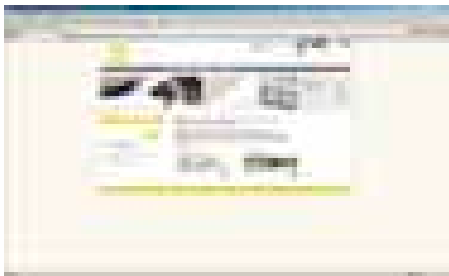

HARKIS® is the abbreviation for **HARTING-Katalog-Informationen-System** (HARTING catalogue information system).

HARKIS® is an electronic catalogue with a part configuration and 3D components library. Here you can choose a connector according to your requirements. Afterwards you are able to send your inquiry directly to a HARTING sales partner. The drawings to every single part are available in PDF-format. The parts are downloadable in 2D-format (DXF) and 3D-format (IGES, STEP). The 3D-models can be viewed with a VRML-viewer.

You can find **HARKIS®** at www.HARKIS.HARTING.com. It is also available on DVD.

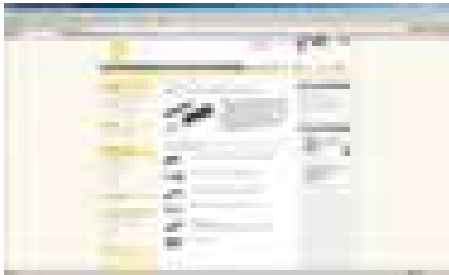

Piece part consulting

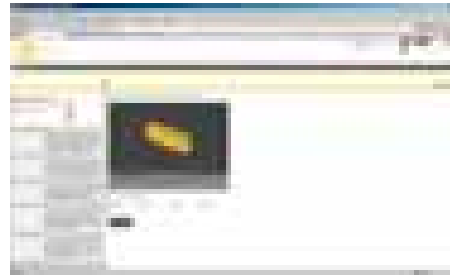

CAD library

Product samples: Fast-track delivery to your desk, free of charge

The new free express sample service in the HARTING catalogue information system (**HARKIS®**) allows customers to order samples immediately, easily and completely free of charge. A broad selection from the device connectivity product portfolio is now available. If a product is unavailable, the system offers alternative products with similar features that can be requested at a mouse click.

The free samples are shipped within 48 hours at no cost to you. This service enables tremendous flexibility, especially in the design phase of projects.

Identification

Part No.

HARKIS® DVD
Basic product catalogue
2D and 3D CAD files inclusive

98 40 000 0405



General information

It is the customer's responsibility to check whether the components illustrated in this catalogue also comply with different regulations from those stated in special fields of applications.

We reserve the right to modify designs or substance of content in order to improve quality, keep pace with technological advancement or meet particular requirements in production.

No part of this catalogue may be reproduced in any form (print, photocopy, microfilm or any other process) or processed, duplicated or distributed by means of electronic systems without the prior written consent of HARTING Electronics GmbH & Co. KG, Espelkamp. We are bound by the German version only.

Transforming customer wishes into concrete solutions



The HARTING Technology Group is skilled in the fields of electrical, electronic and optical connection, transmission and networking, as well as in manufacturing, mechatronics and software creation. The Group uses these skills to develop customized solutions and products such as connectors for energy and data transmission applications including, for example, mechanical engineering, rail technology, wind energy plants, factory automation and the telecommunications sector. In addition, HARTING also produces electro-magnetic components for the automobile industry and offers solutions in the field of Enclosures and Shop Systems.

The HARTING Group currently comprises 36 subsidiary companies and worldwide distributors employing a total of more than 3,450 staff.



HARTING Subsidiary company



HARTING Representatives

We aspire to top performance.

Connectors ensure functionality. As core elements of electrical and optical wiring, connection and infrastructure technologies, they are essential in enabling the modular construction of devices, machines and systems across a very wide range of industrial applications. Their reliability is a crucial factor guaranteeing smooth functioning in the manufacturing area, in telecommunications, applications in medical technology – in fact, connectors are at work in virtually every conceivable application area. Thanks to the consistent further development of our technologies, customers enjoy investment security and benefit from durable, long term functionality.

Always at hand, wherever our customers may be.

Increasing industrialization is creating growing markets characterized by widely diverging demands and requirements. The search for perfection, increasingly efficient processes and reliable technologies is a common factor in all sectors across the globe.

HARTING is providing these technologies – in Europe, America and Asia. The **HARTING** professionals at our international subsidiaries engage in close, partnership based interaction with our customers, right from the very early product development phases, in order to realize customer demands and requirements in the best possible manner.

Our people on location form the interface to the centrally coordinated development and production departments. In this way, our customers can rely on consistently high, superior product quality – worldwide.

Our claim: Pushing Performance.

HARTING provides more than optimally attuned components. In order to serve our customers with the best possible solutions, **HARTING** is able to contribute a great deal more and play a closely integrative role in the value creation process.

From ready assembled cables through to control racks or ready-to-go control desks: Our aim is to generate the maximum benefits for our customers – without compromise!

Quality creates reliability – and warrants trust.

The **HARTING** brand stands for superior quality and reliability – worldwide. The standards we set are the result of consistent, stringent quality management that is subject to regular certifications and audits.

EN ISO 9001, the EU Eco-Audit and ISO 14001:2004 are key elements here. We take a proactive stance to new requirements, which is why **HARTING** ranks among the first companies worldwide to have obtained the new IRIS quality certificate for rail vehicles.



HARTING technology creates added value for customers. Technologies by HARTING are at work worldwide. HARTING's presence stands for smoothly functioning systems, powered by intelligent connectors, smart infrastructure solutions and mature network systems. In the course of many years of close, trust-based cooperation with its customers, the HARTING Technology Group has advanced to one of the worldwide leading specialists for connector technology. Extending beyond the basic functionalities demanded, we offer individual customers specific and innovative solutions. These tailored solutions deliver sustained effects, provide investment security and enable customers to achieve strong added value.

Opting for HARTING opens up an innovative, complex world of concepts and ideas.

In order to develop connectivity and network solutions serving an exceptionally wide range of connector applications and task scopes in a professional and cost optimized manner, HARTING not only commands the full array of conventional tools and basic technologies. Over and beyond these capabilities, HARTING is constantly harnessing and refining its broad base of knowledge and experience to create new solutions that ensure continuity at the same time. In securing this know-how lead, HARTING draws on a wealth of sources from both in-house research and the world of applications alike.

Salient examples of these sources of innovative knowledge include microstructure technologies, 3D design and construction technology, as well as high temperature

or ultrahigh frequency applications that are finding use in telecommunications or automation networks, in the automotive industry, or in industrial sensor and actuator applications, RFID and wireless technologies, in addition to packaging and housing made of plastics, aluminum or stainless steel.

HARTING solutions extend across technology boundaries.

Drawing on the comprehensive resources of the group's technology pool, HARTING devises practical solutions for its customers. Whether this involves industrial networks for manufacturing automation, or hybrid interface solutions for wireless telecommunication infrastructures, 3D circuit carriers with microstructures, or cable assemblies for high-temperature applications in the automotive industry – HARTING technologies offer far more than components, and represent mature, comprehensive solutions attuned to individual customer requirements and wishes. The range covers ready-to-use cable configurations, completely assembled backplanes and board system carriers, as well as fully wired and tested control panels.

In order to ensure the future proof design of RF- and EMC-compatible interface solutions, the central HARTING laboratory (certified to EN 45001) provides simulation tools, as well as experimental, testing and diagnostics facilities all the way through to scanning electron microscopes. In the selection of materials and processes, lifecycle and environmental aspects play a key role, in addition to product and process capability considerations.



HARTING knowledge is practical know-how generating synergy effects.

HARTING commands decades of experience with regard to the applications conditions of connectors in telecommunications, computer and network technologies and medical technologies, as well as industrial automation technologies, such as the mechanical engineering and plant engineering areas, in addition to the power generation industry or the transportation sector. **HARTING** is highly conversant with the specific application areas in all of these technology fields.

The key focus is on applications in every solution approach. In this context, uncompromising, superior quality is our hallmark. Every new solution found will invariably flow back into the **HARTING** technology pool, thereby enriching our resources. And every new solution we go on to create will draw on this wealth of resources in order to optimize each and every individual solution. In this way, **HARTING** is synergy in action.

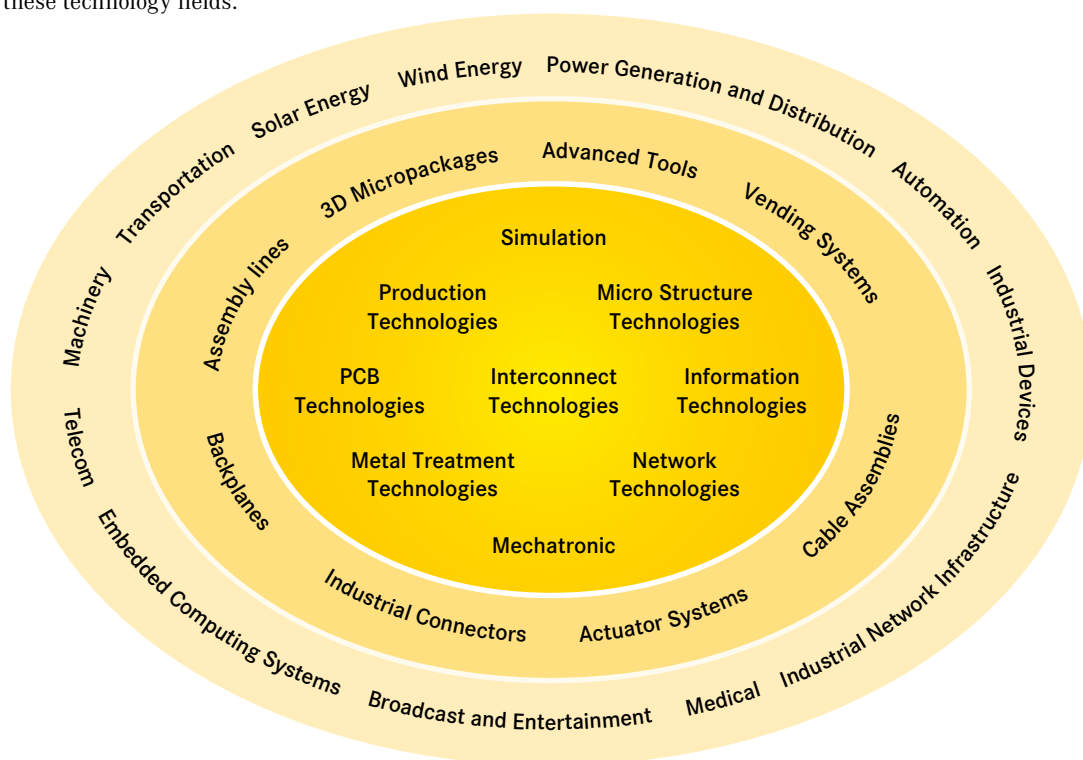

DIN 41 612 type 3C Crimp

Nowadays, many PCBs are smaller than the standard size 3HE. HARTING offers a new crimp connector with housing in order to assemble cables that require less space.

The well-known and reliable BC crimp contacts are used for this product.

For further details see page 20.08.



DIN 41 612 type 3C Crimp

Fixing brackets for full metal housings D20

The new metallized fixing brackets give a robust mechanical connection with reliable screws and additionally through our new screwless locking solution. Moreover a good electrical connection is guaranteed between the full metal housings D20, the fixing brackets and the rack systems.

The locking levers simplify the handling notably and can also be used for daughter cards mounting and removal.

For further details see page 20.31.

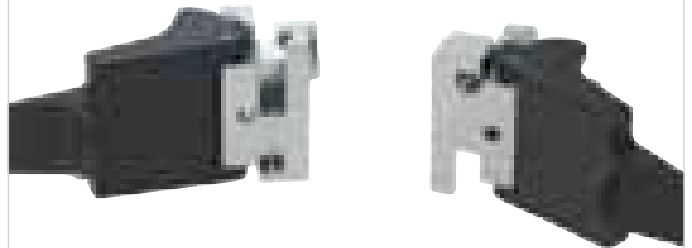

Fixing brackets

DIN 41612 Female connector H 15 with press-in pins

Type H15 is used successfully as power connector for many years. Now, HARTING offers a female connector type H15 with press-in pins. Press-in is already our fourth termination technology for female connector type H15 besides cage clamp, solder and faston.

The new portfolio includes two versions with 5.08 mm and 10.16 mm position separation on the termination side.

For further details see page 04.15.

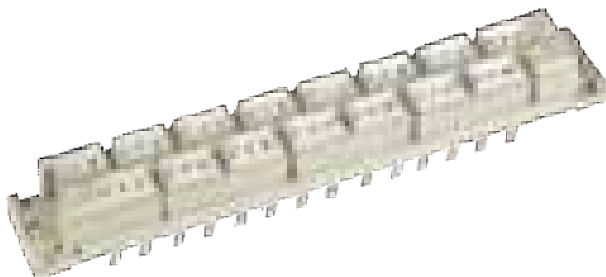

DIN 41 612 female connector H15 press-in

DIN 41612 new type H16 male- and female connectors

The new type H16 offers an additional contact compared to standard type H15. H16 can be used for specific applications, which require high density connectors.

For further details see page 04.16.



DIN 41 612 type H 16

Printed Board Connectors according to DIN 41 612 / IEC 60 603-2

Chapter

Printed Board Connectors – general information

00

DIN Signal (up to 2 A)
Types B, 2B, 3B, C, 2C, 3C, M,
M invers, Q, 2Q, R, 2R

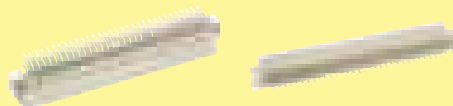

01

Busbars



02

DIN Power (up to 6 A)
Types D, E, F, FM, 2F, F9,
interface connectors I/U



03

DIN Power (up to 15 A)
Types H, H15, H16, H3, MH



04

Shell housings



20

Tooling



30

List of part numbers

40

Addresses

50



Economic and Reliable Connections

Connector system for use in 19" racks to DIN 41 494 (replaced by DIN EN 60297-3).

Connectors according to

IEC 60603-2
DIN 41 612
(replaced by IEC 60603-2)

UL-listed E 102079 (M)
CECC 75101-801
IEC 61076-4-113

Developed for economical assembly of electronic plant and equipment.

HARTING offers the most comprehensive range of highly versatile connectors complemented by many styles of shell housings for a complete interconnection and interface system.



UL-listed E 102079 (M)



The division Printed Board Connectors is certified according to EN ISO 9001



DIN 41 612 connectors are in conformity with the
Directive 2002/95/EG
EC Directive on the Restriction and Use
of Certain Hazardous Substances in Electrical
and Electronic Devices
RoHS

The advantages

- Indirect mating (male/female)
- Automated production processes
- Continuous quality assurance
- 3-160 contacts
- Complete interconnection system
- Numerous interface connectors
- A wide variety of hoods
- Many termination technologies provide for the lowest installed cost
- Contacts selectively gold-plated
- Tinned terminations for increased solderability

The terminations

- Wrap posts for automated wiring
- Straight and angled solder pins for printed circuits
- High temperature connectors for reflow soldering
- Solder lugs for discrete wiring
- Press-in technology for backplanes
- Crimp contacts for selective loading
- Insulation displacement contacts for mass production
- Faston blades for higher power discrete wiring
- Cage-clamp contacts provide low cost connection for solid or stranded wires

For "non standard applications" we can manufacture designs to match your requirements. Please discuss your requirements with us.

HARTING printed board connectors incorporate the latest design features and provide the assurance of high quality and reliability with economy.



Printed Board Connectors – general information

Page

Creepage and clearance distances, CTI	00.04
Specifications, assembly instructions	00.06
System description	00.08
Male and female connectors with pcb fixings	00.12
Coding systems	00.14
NFF classification	00.17
Terminations	00.18

**General
information**



Extract DIN VDE 0110-04.97*)

This standard is a technical adaptation of IEC Report 664/664A and specifies, in general, the minimum insulation distances for equipment. It can be used by committees to protect persons and property in the best possible way from the effects of electrical voltages or currents (e.g. fire hazard) or from functional failure of the equipment by providing adequate dimensioning of clearances and creepage distances in equipment.

Rated impulse withstand voltage

In allocation of the equipment to an installation category, the following factors shall be taken into account:

- Overvoltages which can enter the equipment from outside across the terminals.
- Overvoltages generated in the equipment itself and occurring at the terminals.

The following parameters apply to:

Installation category I

Equipment is intended for use only in appliances or installation parts, in which no overvoltages can occur.

Equipment in this installation category is normally operated at extra low voltage.

Installation category II

Equipment is intended for use in installations or parts of installations, in which lightning overvoltages need not be considered. Overvoltages caused by switching must be taken into account.

This includes for example domestic appliances.

Installation category III

Equipment is intended for use in installations or parts of installations, in which lightning overvoltages need not be considered, but which are subject to particular requirements with regard to the safety and availability of the equipment and its supply systems.

This includes equipment for fixed installation such as protective devices, relays, switches and sockets.

Installation category IV

Equipment is intended for use in installations or parts of installations, in which lightning overvoltages must be taken into account.

This includes equipment for connection to overhead lines such as omnidirectional control receivers and meters.

For circuits or parts of circuits inside the equipment, clearances may be dimensioned directly for the expected overvoltages. If the expected overvoltages are not impulse voltages but DC or AC voltages, the maximum value of these voltages shall be determined as the rated impulse withstand voltage for clearances both for homogeneous and inhomogeneous field.

Degree of pollution

Pollution degree 1: No pollution or only dry, non-conductive pollution occurs. The pollution has no influence.

Pollution degree 2: Only non-conductive pollution occurs. A temporary conductive caused by condensation must be expected occasionally.

The degrees of pollution 3 and 4 are in this case not considered, as they are not relevant for the connectors shown in this catalogue.

Clearance

The clearance is defined as shortest distance through the air between two conductive elements.



To identify the clearance distance

- Define the installation category
- Define the degree of pollution expected
- Select the rated impulse withstand voltage from table 00.01
- Select the minimum required clearance from table 00.02

Exemplary calculation

What voltage can be used, if the clearance, the installation category and the degree of pollution are known:

Clearance	Installation category	Degree of pollution	Voltage phase-to-earth
1.2 mm	II	2	150 V
3.0 mm	II	2	600 V
4.5 mm	II	2	600 V

Creepage

The creepage is defined as shortest distance on the surface of an insulating material between two conductive elements.



To identify the creepage distance

- Define the installation category
- Define the degree of pollution expected
- From the nominal voltage and the type of supply system select the rated voltage from table 00.03 a/b
- From the rated voltage and degree of pollution select the minimum creepage and CTI group of the connector required in table 00.04

For the dimensioning of the creepage distance the tracking formation of the insulating material has to be considered. If not indicated contrary, the CTI value of the insulating material is <400 and the isolation group is III a/b.

*) It is the users responsibility to ensure that the complete current issue of the specification is considered.



Exemplary calculation

What voltage can be used, if the creepage, the installation category and the degree of pollution are known:

Creepage	1.2 mm		3.0 mm		8.0 mm	
Installation category	II		II		II	
Degree of pollution	2		2		2	
CTI-Value	< 400	> 400	< 400	> 400	< 400	> 400
Isolation group	III a/b	II	III a/b	II	III a/b	II
Rated voltage	50 V	160 V	250V	400 V	800 V	1,000 V
Nominal voltage of supply system	50 V	150 V	220 V	380 V	720 V	1,000 V

How to identify the maximum voltage

1. Define the installation category
2. Define the degree of pollution expected
3. Select the rated impulse withstand voltage in kV from table 00.02
4. Select the voltage phase to earth derived from rated system voltages from table 00.01
5. Select the rated voltage from table 00.04
6. Define the number of phases and whether table 00.03 a or table 00.03 b is relevant for the application
7. Select the nominal voltage of supply system from table 00.03 a or 00.03 b
8. Select the lower voltage from point 4 and 7

Table 00.01

Voltages phase-to-earth derived from rated system voltages up to $U_{r.m.s.}$ and U_n	Rated impulse withstand voltages in kV for installation category (Voltage form: 1.2/50 μ s according to DIN IEC 60 060-1)			
	I	II	III	IV
50	0.33	0.50	0.80	1.5
100	0.50	0.80	1.5	2.5
150	0.80	1.5	2.5	4.0
300	1.5	2.5	4.0	6.0
600	2.5	4.0	6.0	8.0
1000	4.0	6.0	8.0	12.0

Table 00.02

Rated impulse withstand voltage in kV	Minimum clearances in mm up to 2000 m above sea level ¹⁾			
	Case A (Inhomogeneous field ³⁾)		Case B (Homogeneous field ²⁾)	
	Pollution degree		Pollution degree	
	1	2	1	2
0.33	0.01	0.2	0.01	0.2
0.50	0.04		0.04	
0.80	0.1		0.1	
1.5	0.5	0.5	0.3	0.3
2.5	1.5	1.5	0.6	0.6
4.0	3	3	1.2	1.2
6.0	5.5	5.5	2	2
8.0	8	8	3	3

¹⁾ For higher altitudes see table 2b from DIN VDE 0110 for multiplying factors.

²⁾ Verification by an impulse voltage test is required if the clearance is less than the value specified for case A.

³⁾ Point to plane.

Table 00.03 a. Single phase, three or two wire AC or DC systems

Nominal voltage of supply system ¹⁾	Rated voltage in V	
	Phase-to-phase All systems (between conductors of different polarity for U _n)	Phase-to-earth - -
$U_{r.m.s.}$ or U_n in V	$U_{r.m.s.}$ or U_n	$U_{r.m.s.}$ or U_n
12.5	12.5	-
24	25	-
25	25	-
30	32	-
42	50	-
48	50	-
50 ²⁾	50	-
60	63	-
60/30	63	32
100 ²⁾	100	-
110	125	-
120	125	-
150 ²⁾	160	-
220	250	-
220/110	250	125
240/120	250	125
300 ²⁾	320	-
440/220	500	250
600 ²⁾	630	-
480/960	1000	500
1000 ²⁾	1000	-

Table 00.03 b. Three phase, four or three wire AC systems

Nominal voltage of supply system ¹⁾	Rated voltage in V		
	Phase-to-phase All systems	Phase-to-earth	
$U_{r.m.s.}$ in V	$U_{r.m.s.}$	$U_{r.m.s.}$	$U_{r.m.s.}$
60	63	32	63
110	125	80	125
120	125	80	125
127	125	80	125
150 ²⁾	160	-	160
208	200	125	200
220	250	160	250
230	250	160	250
240	250	160	250
300 ²⁾	320	-	320
380	400	250	400
400	400	250	400
415	400	250	400
440	500	250	500
480	500	320	500
500	500	320	500
575	630	400	630
600 ²⁾	630	-	630
660	630	400	630
690	630	400	630
720	800	500	800
830	800	500	800
960	1000	630	1000
1000 ²⁾	1000	-	1000

¹⁾ This voltage can be the same as the rated voltage of the equipment.

²⁾ These values correspond to the values of table 00.01.

In countries where both star and delta, earthed and unearthed supply systems are used the values for delta systems only should be used. Systems earthed across impedances are treated as unearthed systems.

Table 00.04

Rated voltage (V) $U_{r.m.s.}$ or U_n	12.5	25	32	50	63	80	100	125	160	200	250	320	400	500	630	800	1000
Minimum creepage distance (mm)																	
Degree of pollution 1:																	
CTI group II + III a/b	0.09	0.125	0.14	0.18	0.2	0.22	0.25	0.28	0.32	0.42	0.56	0.75	1	1.3	1.8	2.4	3.2
Degree of pollution 2:																	
CTI group III a/b	0.42	0.5	0.53	1.2	1.25	1.3	1.4	1.5	1.6	2	2.5	3.2	4	5	6.3	8	10
CTI group II	0.42	0.5	0.53	0.85	0.9	0.95	1	1.05	1.1	1.4	1.8	2.2	2.8	3.5	4.5	5.6	7.1

Performance level 3 as per IEC 60 603-2

50 mating cycles then visual inspection.
No gas test.
No functional impairment.

Part No. explanation 09 7...

Performance level 2 as per IEC 60 603-2

400 mating cycles. then 4 days gas test using 10 ppm SO₂.
200 mating cycles. Measurement of contact resistance.
200 mating cycles. then visual inspection. No abrasion of the contact finish through to the base material.
No functional impairment.

Part No. explanation 09 6...

Performance level 1 as per IEC 60 603-2

500 mating cycles. then 10 days gas test using 10 ppm SO₂.
250 mating cycles. Measurement of contact resistance.
250 mating cycles. then visual inspection. No abrasion of the contact finish through to the base material.
No functional impairment.

Part No. explanation 09 2...

Performance level 2 as per IEC 61 076-4-113

250 mating cycles. then 4 days gas test using 10 ppm SO₂.
125 mating cycles. Measurement of contact resistance.
125 mating cycles. then visual inspection. No abrasion of the contact finish through to the base material.
No functional impairment.

Part No. explanation 02 2...

Performance level 1 as per IEC 61 076-4-113

500 mating cycles. then 10 days gas test using 10 ppm SO₂.
250 mating cycles. Measurement of contact resistance.
250 mating cycles. then visual inspection. No abrasion of the contact finish through to the base material.
No functional impairment.

Part No. explanation 02 1...

Other plating finishes available on request.

Mating conditions

To ensure reliable connections and prevent unnecessary damage, please refer to the application data diagrams.

These recommendations are set out in IEC 60 603-2.

The connectors should not be coupled and decoupled under electrical load.

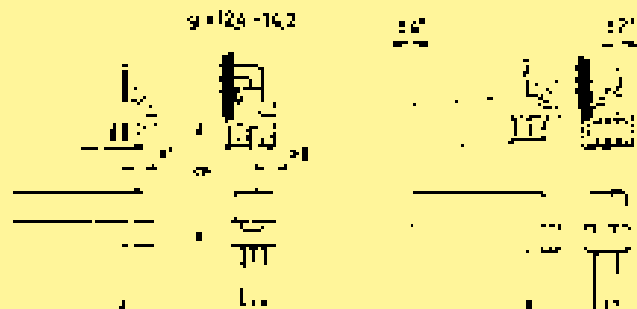

Soldering the male connectors into pcb's

Male connectors should be protected when being soldered in a dip, flow or film soldering baths. Otherwise, they might become contaminated as a result of soldering operations or deformed as a result of overheating.

- ① For prototypes and short runs protect the connectors with an industrial adhesive tape, e.g. Tesaband 4331 (www.tesa.de). Cover the underside of the connector moulding and the adjacent parts of the pcb as well as the open sides of the connector. This will prevent heat and gases of the soldering apparatus from damaging the connector. About 140 + 5 mm of the tape should suffice.
- ② For large series a jig is recommended. Its protective cover with a fast action mechanical locking device shields the connectors from gas and heat generated by the soldering apparatus. As an additional protection a foil can be used for covering the parts that should not be soldered.
- ③ For prototypes and short runs the protection described under point ① can be replaced by a solder protection cap. This cap can be ordered under the part no. 09 02 000 9935.

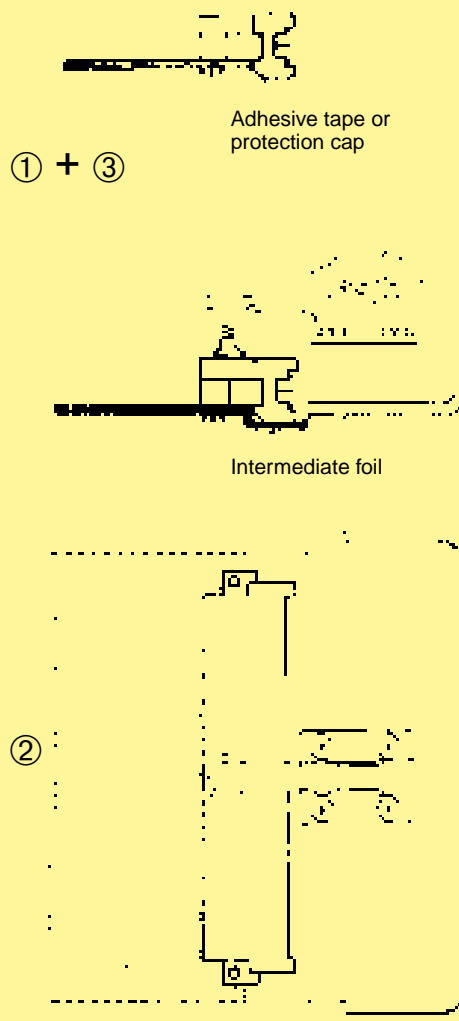

Design of connectors

- Standard fixing arrangement
- Standard positions for pcb's and connectors provide a modular system in the card frame and a standard front panel system.
- Standard wiring matrix on the connection side for female connectors built up on a 2.54 mm (0.1" centres) grid. (This facilitates automatic wiring).
- Printed circuit boards with standard dimensions 100 x 160 resp. 233.4 x 160 mm as set out in DIN EN 60 297-3 standard sizes 3 U and 6 U.

Building up card frame systems

In the basic frame unit according to DIN EN 60297-3 pcb's are inserted from the front and make contact with the connectors fitted to the back. This basic arrangement gives the following advantages:

- When using conventional connectors on the back of the card frames, space is left above, below and in the middle along the horizontal line of the frame which can be used to fit extra connectors for cross connection or making plug connections by means of flying lead connectors.
- Using the HARTING system one can also connect flying lead connectors onto the front of the frame or even onto the inside of the back of the frame. This means that external equipment can easily be monitored, controlled or tested from the card frame itself.

Complementary components

All connectors can be supplied with a complete range of accessories. These can be fitted above or below the wiring plane on the back of the card frame or on the front of the card frame. These connectors and accessories provide a complete connector system suitable for commonly used wiring techniques.

- The flying lead connector consists of a connector with crimp or solder contacts and a shell housing. The flying lead connector is latched or retained in position using screw fixings and is compatible with a corresponding male connector and interface connectors I and U.
- Fixing brackets prohibit the withdrawal of the pcb when a flying lead connector is used on the front side of the card frame.
- The interface connector I has blade contacts on the plug side and solder pins, wrap posts or crimp terminals on the termination side. It replaces the female connector type F fitted into the frame and allows interfacing to the internal wiring of the card frame with the help of the flying lead connector on the back of the card frame unit.
- On the one plane the interface connector U has male contacts that are compatible with the flying lead connector. On the other plane it has wrap posts for interfacing to the internal wiring of the card frame. It can be mounted on the back of the card frame above or below other connectors arranged upright. Its wrap posts follow the same pitch as other connectors therefore allowing automated wiring. By using the U connector with the flying lead connector plug-in connections between the card frame and the peripheral equipment/ outlying stations are made easy.

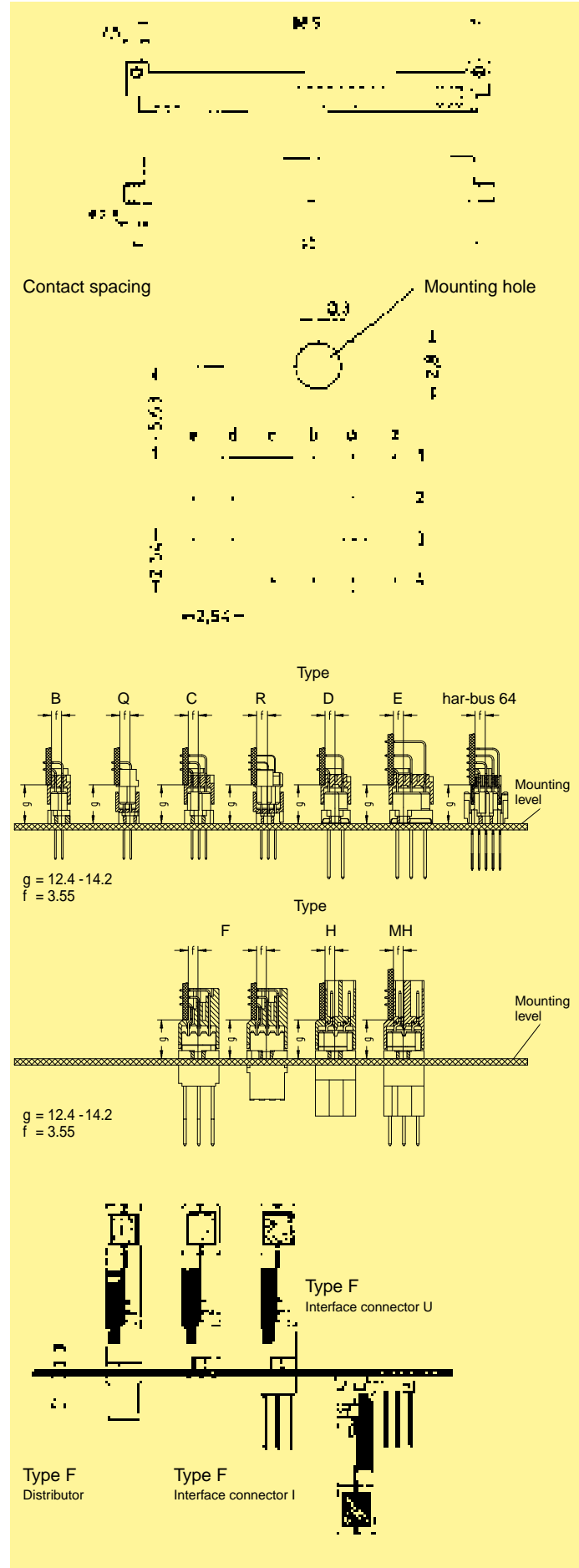

General information

Type	B, Q	C, R	D
Wiring side (Rear side)	Input access from the front side via a female connector	Input access via a female connector	Input access from the front side via a female connector Piggyback connector
Soldering technique for a flexible wiring			
Soldering technique for pcb Press-in technique for pcb			
Crimp connections			
Wrapped connections posts 0.6 x 0.6 mm 1 x 1 mm	 0.6 x 0.6 mm	 0.6 x 0.6 mm	 1 x 1 mm
Middle section 			
Front side 			











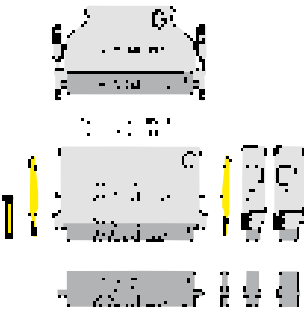
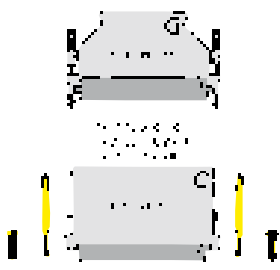



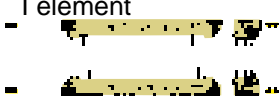



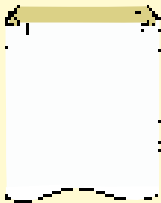
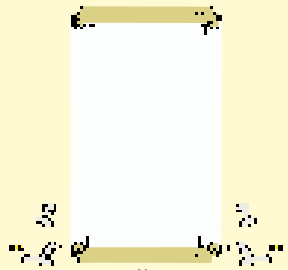
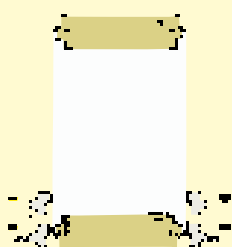
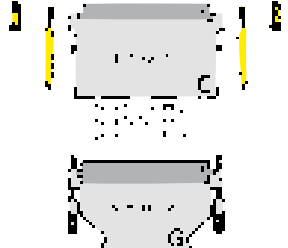
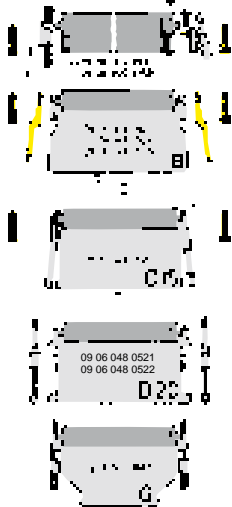

1) Screw fixing (cheesehead screw M 2.5 x 16 + nut) 09 02 000 9909

2) 2 x screw fixing
(cylindric screw M 2.5 x 25 DIN EN ISO 1207 + nut M 2.5 DIN EN ISO 4032)

3) Fixing brackets for latching and screw fixing







4) Screw length depends on the pcb thickness

f = female connector
m = male connector
R = right hand
L = left hand

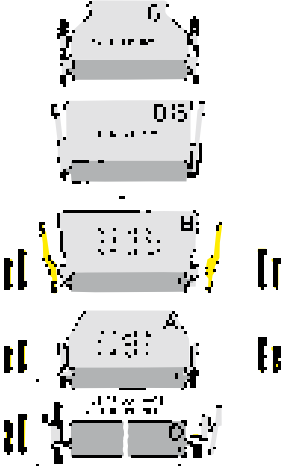
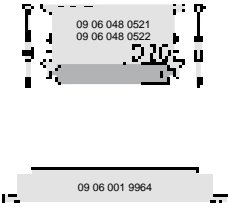
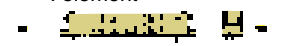
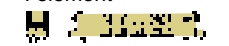
Kategorie 04	E		H																					
Input access from the front side via a female connector 	Input access via a female connector Piggyback connector 		Input access from the front side via a female connector 																					
																								
			I element 																					
																								
	 1 x 1 mm																							
																								
																								
Y =			<table border="1"> <thead> <tr> <th data-bbox="547 1865 646 2027">Combinations</th> <th colspan="2" data-bbox="646 1865 981 1915">Fixing bracket c for male connectors</th> <th data-bbox="981 1865 1069 1915">I element</th> <th data-bbox="1069 1865 1161 1915">U element</th> </tr> </thead> <tbody> <tr> <td data-bbox="547 1915 646 2027"></td> <td data-bbox="646 1915 790 2027"> Multiple fixing  </td> <td data-bbox="790 1915 981 2027"> Single fixing  </td> <td data-bbox="981 1915 1069 2027">  </td> <td data-bbox="1069 1915 1161 2027">  </td> </tr> <tr> <td data-bbox="547 2027 646 2098">Housing C</td> <td colspan="2" data-bbox="646 2027 981 2098">latchable</td> <td data-bbox="981 2027 1069 2098">latch and screw fixing (M 2.5 x 16)</td> <td data-bbox="1069 2027 1161 2098">latch and screw fixing</td> </tr> <tr> <td data-bbox="547 2098 646 2098">Housing G</td> <td colspan="2" data-bbox="646 2098 981 2098"></td> <td data-bbox="981 2098 1069 2098">screw fixing</td> <td data-bbox="1069 2098 1161 2098">screw fixing</td> </tr> </tbody> </table>		Combinations	Fixing bracket c for male connectors		I element	U element		Multiple fixing 	Single fixing 			Housing C	latchable		latch and screw fixing (M 2.5 x 16)	latch and screw fixing	Housing G			screw fixing	screw fixing
Combinations	Fixing bracket c for male connectors		I element	U element																				
	Multiple fixing 	Single fixing 																						
Housing C	latchable		latch and screw fixing (M 2.5 x 16)	latch and screw fixing																				
Housing G			screw fixing	screw fixing																				

General information

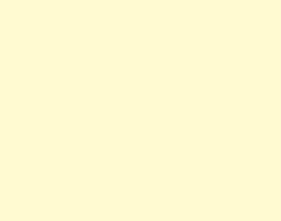
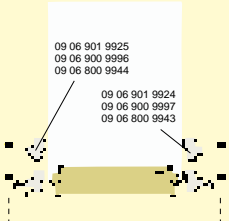
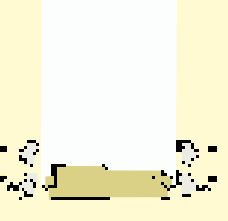
Type	F			
Wiring side (Rear side)	Input access via a female connector		Output from the front side via a male connector	
	Piggyback connector 		Piggyback connector 	
Soldering technique for a flexible wiring				
Soldering technique for pcb Press-in technique for pcb		Element 		
Crimp connections		Element 		
Wrapped connections posts 1 x 1 mm		Element 		
Middle section 				
Front side 				
	</			

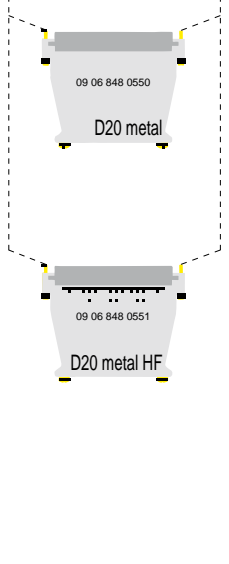
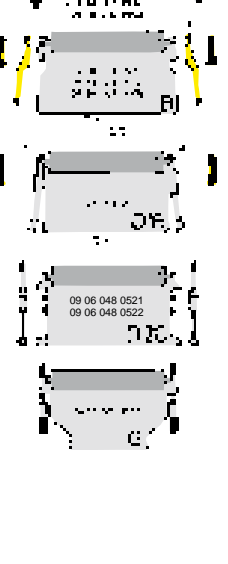
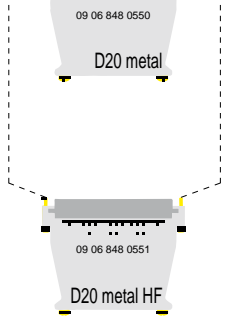
F	F, H, MH 24 + 7	MH 24 + 7																																																															
<p>Input access from the wiring side via a female connector</p> 		<p>Input access from the front side via a female connector</p>	<table border="1"> <thead> <tr> <th colspan="4" data-bbox="986 315 1511 349">Ia</th> </tr> <tr> <th data-bbox="986 349 1098 483">Combinations</th> <th colspan="2" data-bbox="1098 349 1305 483">Fixing bracket a for male connectors</th> <th colspan="2" data-bbox="1305 349 1511 483">Fixing bracket b for male connectors</th> </tr> <tr> <td></td> <th data-bbox="1098 383 1209 483">Multiple fixing</th> <th data-bbox="1209 383 1305 483">Single fixing</th> <th data-bbox="1305 383 1417 483">Multiple fixing</th> <th data-bbox="1417 383 1511 483">Single fixing</th> </tr> </thead> <tbody> <tr> <td>Housing A</td> <td colspan="2" data-bbox="1098 483 1305 517">latch (M 2.5 x 12) and screw fixing</td> <td colspan="2" data-bbox="1305 483 1511 517">latchable</td> </tr> <tr> <td>Housing B</td> <td colspan="2" data-bbox="1098 517 1305 551"></td> <td colspan="2" data-bbox="1305 517 1511 551">latch (M 2.5 x 20) and screw fixing</td> </tr> <tr> <td>Housing D15</td> <td colspan="2" data-bbox="1098 551 1305 584"></td> <td colspan="2" data-bbox="1305 551 1511 584">latch (M 2.5 x 20) and screw fixing</td> </tr> <tr> <td>Housing D20</td> <td colspan="2" data-bbox="1098 584 1305 618"></td> <td colspan="2" data-bbox="1305 584 1511 618">screw fixing</td> </tr> <tr> <td>Housing G</td> <td colspan="2" data-bbox="1098 618 1305 651"></td> <td colspan="2" data-bbox="1305 618 1511 651">screw fixing</td> </tr> <tr> <td>(...9930)</td> <td colspan="2" data-bbox="1098 651 1305 685"></td> <td colspan="2" data-bbox="1305 651 1511 685">latch (M 2.5 x 20) and screw fixing</td> </tr> <tr> <td>Comb. O (...9968)</td> <td colspan="2" data-bbox="1098 685 1305 719"></td> <td colspan="2" data-bbox="1305 685 1511 719">screw fixing</td> </tr> <tr> <td>(...9930)</td> <td colspan="2" data-bbox="1098 719 1305 752"></td> <td colspan="2" data-bbox="1305 719 1511 752">latch (M 2.5 x 20) and screw fixing</td> </tr> <tr> <td>Comb. L (...9968)</td> <td colspan="2" data-bbox="1098 752 1305 786"></td> <td colspan="2" data-bbox="1305 752 1511 786">screw fixing</td> </tr> </tbody> </table>				Ia				Combinations	Fixing bracket a for male connectors		Fixing bracket b for male connectors			Multiple fixing	Single fixing	Multiple fixing	Single fixing	Housing A	latch (M 2.5 x 12) and screw fixing		latchable		Housing B			latch (M 2.5 x 20) and screw fixing		Housing D15			latch (M 2.5 x 20) and screw fixing		Housing D20			screw fixing		Housing G			screw fixing		(...9930)			latch (M 2.5 x 20) and screw fixing		Comb. O (...9968)			screw fixing		(...9930)			latch (M 2.5 x 20) and screw fixing		Comb. L (...9968)			screw fixing	
Ia																																																																	
Combinations	Fixing bracket a for male connectors		Fixing bracket b for male connectors																																																														
	Multiple fixing	Single fixing	Multiple fixing	Single fixing																																																													
Housing A	latch (M 2.5 x 12) and screw fixing		latchable																																																														
Housing B			latch (M 2.5 x 20) and screw fixing																																																														
Housing D15			latch (M 2.5 x 20) and screw fixing																																																														
Housing D20			screw fixing																																																														
Housing G			screw fixing																																																														
(...9930)			latch (M 2.5 x 20) and screw fixing																																																														
Comb. O (...9968)			screw fixing																																																														
(...9930)			latch (M 2.5 x 20) and screw fixing																																																														
Comb. L (...9968)			screw fixing																																																														
<p>I element</p> 	<p>I element</p> 		<table border="1"> <thead> <tr> <th colspan="4" data-bbox="986 842 1511 875">Ib</th> </tr> <tr> <th data-bbox="986 875 1098 999">Combinations</th> <th data-bbox="1098 875 1305 999">Fixing bracket b for female connectors</th> <th data-bbox="1305 875 1417 999">I element</th> <th data-bbox="1417 875 1511 999">U element</th> </tr> </thead> <tbody> <tr> <td>Housing A</td> <td data-bbox="1098 931 1305 999" rowspan="2">latchable</td> <td colspan="2" data-bbox="1305 999 1511 1032">(M 2.5x22) latch and (M 2.5x16) screw fixing</td> </tr> <tr> <td>Housing B</td> <td colspan="2" data-bbox="1305 1032 1511 1066">(M 2.5x26) latch and (M 2.5x20) screw fixing</td> </tr> <tr> <td>Housing D15</td> <td data-bbox="1098 1066 1305 1099">latchable</td> <td colspan="2" data-bbox="1305 1066 1511 1099">latchable</td> </tr> <tr> <td>Housing G</td> <td data-bbox="1098 1099 1305 1133"></td> <td colspan="2" data-bbox="1305 1099 1511 1133">screw fixing</td> </tr> <tr> <td>(...9930)</td> <td data-bbox="1098 1133 1305 1167"></td> <td colspan="2" data-bbox="1305 1133 1511 1167">latchable</td> </tr> <tr> <td>Comb. O (...9968)</td> <td data-bbox="1098 1167 1305 1200"></td> <td colspan="2" data-bbox="1305 1167 1511 1200">(M 2.5x26) screw fixing (M 2.5x20)</td> </tr> <tr> <td>Comb. M</td> <td data-bbox="1098 1200 1305 1234">latchable</td> <td colspan="2" data-bbox="1305 1200 1511 1234"></td> </tr> </tbody> </table>				Ib				Combinations	Fixing bracket b for female connectors	I element	U element	Housing A	latchable	(M 2.5x22) latch and (M 2.5x16) screw fixing		Housing B	(M 2.5x26) latch and (M 2.5x20) screw fixing		Housing D15	latchable	latchable		Housing G		screw fixing		(...9930)		latchable		Comb. O (...9968)		(M 2.5x26) screw fixing (M 2.5x20)		Comb. M	latchable																										
Ib																																																																	
Combinations	Fixing bracket b for female connectors	I element	U element																																																														
Housing A	latchable	(M 2.5x22) latch and (M 2.5x16) screw fixing																																																															
Housing B		(M 2.5x26) latch and (M 2.5x20) screw fixing																																																															
Housing D15	latchable	latchable																																																															
Housing G		screw fixing																																																															
(...9930)		latchable																																																															
Comb. O (...9968)		(M 2.5x26) screw fixing (M 2.5x20)																																																															
Comb. M	latchable																																																																
<p>U element</p> 			<table border="1"> <thead> <tr> <th colspan="5" data-bbox="986 1290 1511 1323">II</th> </tr> <tr> <th data-bbox="986 1323 1126 1357">Housing B/D 15</th> <th colspan="2" data-bbox="1126 1323 1305 1357">II a</th> <th colspan="2" data-bbox="1305 1323 1511 1357">II b</th> </tr> </thead> <tbody> <tr> <td>09 06 048 0503</td> <td>2x</td> <td>09 06 000 9913</td> <td>and/or 2x</td> <td>09 06 000 9926</td> </tr> <tr> <td>09 06 048 0504</td> <td>1x</td> <td>{ 09 06 000 9913 09 06 000 9919</td> <td>and/or 2x</td> <td>09 06 000 9926</td> </tr> <tr> <td>09 06 048 0505</td> <td>1x</td> <td>{ 09 06 000 9913 09 06 000 9919</td> <td>and/or 2x</td> <td>09 06 000 9926</td> </tr> <tr> <td>09 06 048 0515</td> <td>-</td> <td>-</td> <td>and 2x</td> <td>09 06 000 9926</td> </tr> <tr> <td>Comb. O + L</td> <td>2x 2x</td> <td>09 06 000 9930 09 06 000 9968</td> <td>and 2x -</td> <td>09 06 000 9926 -</td> </tr> <tr> <td>Comb. M</td> <td>2x</td> <td>09 06 000 9930</td> <td>-</td> <td>-</td> </tr> </tbody> </table>				II					Housing B/D 15	II a		II b		09 06 048 0503	2x	09 06 000 9913	and/or 2x	09 06 000 9926	09 06 048 0504	1x	{ 09 06 000 9913 09 06 000 9919	and/or 2x	09 06 000 9926	09 06 048 0505	1x	{ 09 06 000 9913 09 06 000 9919	and/or 2x	09 06 000 9926	09 06 048 0515	-	-	and 2x	09 06 000 9926	Comb. O + L	2x 2x	09 06 000 9930 09 06 000 9968	and 2x -	09 06 000 9926 -	Comb. M	2x	09 06 000 9930	-	-																			
II																																																																	
Housing B/D 15	II a		II b																																																														
09 06 048 0503	2x	09 06 000 9913	and/or 2x	09 06 000 9926																																																													
09 06 048 0504	1x	{ 09 06 000 9913 09 06 000 9919	and/or 2x	09 06 000 9926																																																													
09 06 048 0505	1x	{ 09 06 000 9913 09 06 000 9919	and/or 2x	09 06 000 9926																																																													
09 06 048 0515	-	-	and 2x	09 06 000 9926																																																													
Comb. O + L	2x 2x	09 06 000 9930 09 06 000 9968	and 2x -	09 06 000 9926 -																																																													
Comb. M	2x	09 06 000 9930	-	-																																																													
			<ol style="list-style-type: none"> 1) Fixing brackets for latch and screw fixing 2) Screw M 2.5 x 22 belongs to supply of I elements, nut M 2.5 DIN EN ISO 4036 does not belong to scope of supply 3) Screw fixing (cheesehead screw M 2.5 x 20 + nut) 09 06 000 9926 4) Screw fixing (cheesehead screw M 2.5 x 16 + nut) 09 02 000 9909 5) Cheesehead screw (M 2.5 x 26) 09 06 000 9955, nut M 2.5 DIN EN ISO 4036 does not belong to scope of supply 6) Screw M 2.5 x 20 belongs to the junction element, hexagonal nut M 2.5 DIN EN ISO 4036 does not belong to scope of supply <p>Following items don't belong to scope of supply</p> <ol style="list-style-type: none"> 7) Screw M 2.5 x 12 and nut M 2.5 DIN EN ISO 4036 8) Screw M 2.5 x 8 9) Screw M 2.5 x 8 and nut M 2.5 DIN EN 4032 10) Screw M 2.5 x 25 and nut M 2.5 DIN EN 4032 <p>f = female connector m = male connector R = right hand L = left hand</p>																																																														
																																																																	

The automated insertion of components into pcb's is increasing.

To meet this market demand, HARTING has developed connectors which can be assembled and fixed to the pcb in one process.

To fix the connectors HARTING offers snap-in clips as well as kinked pins.

Snap-in clips

In the soldering process, all component terminations including the snap-in clips are soldered and therefore mechanically secured. This provides mechanical protection for the soldered contacts during mating and unmating of the connector.

Mouldings with snap-in clips offer the following advantages:

- Cost reduction when compared with the screw or rivet assembly methods due to the soldering of the clip along with other components in one process.
- The orientation of the clip after soldering in the plated through hole provides mechanical protection against the tensile forces arising from the mating and unmating of the connector.

It is possible to supply the majority of male and female connectors with solder termination with snap-in clips (existing articles see product pages).

For pcb thickness
 $1.6 \pm 0.2 \text{ mm}$
 $\varnothing = 2.8 + 0.1 \text{ mm}$

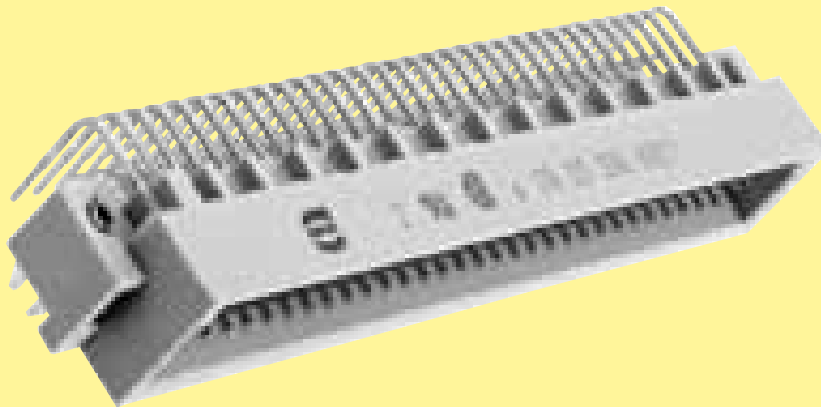

Mounting force
40 - 60 N

For pcb thickness
1.6 - 4.0 mm
 $\varnothing = 2.8 + 0.1 \text{ mm}$

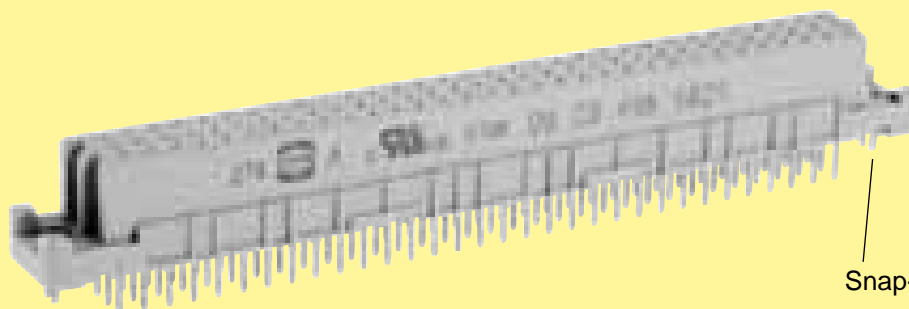

Snap-in clip



Kinked pins

Before and during soldering, the connectors are fixed onto the pcb with four kinked contacts located in the rows a and c, e.g. the positions a1, c1, a32 and c32 for a fully loaded connector.

Connectors with kinked pins are a reliable alternative for female connectors with straight terminations because no additional elements like screws, rivets or clips are necessary.

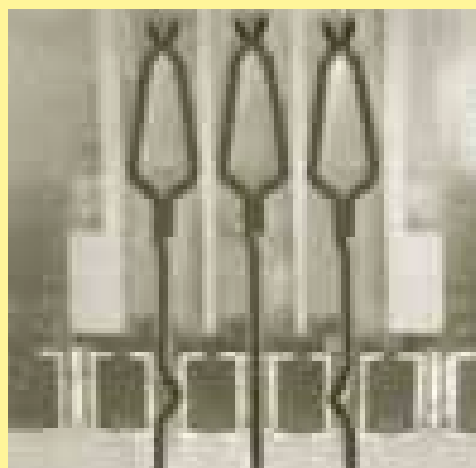
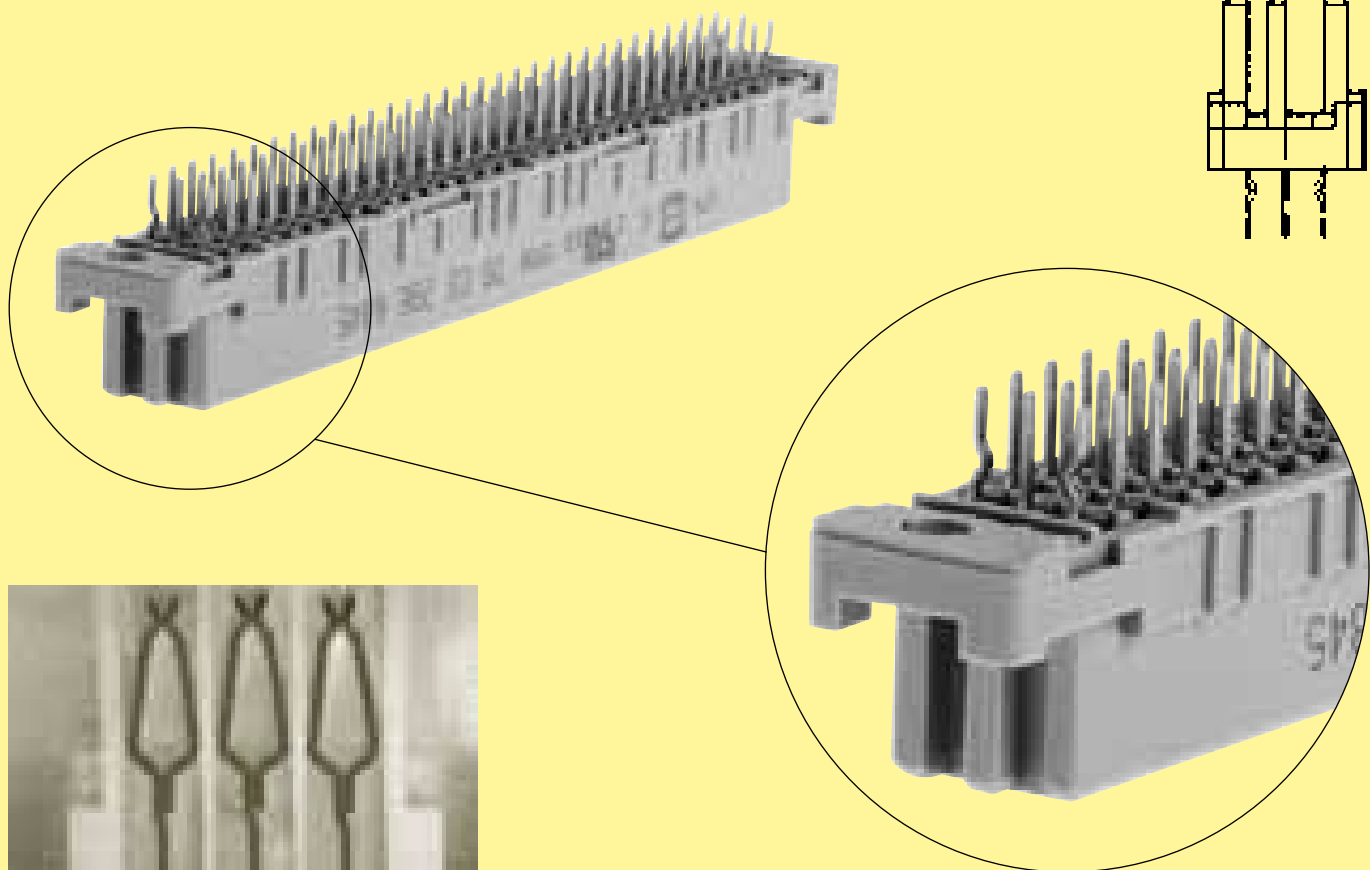

Connectors see chapter 01, type C.



Cross section of a connector with kinked contacts assembled to a pcb

Dimension of the plated through hole [mm]	Mounting force [N]	Retention force [N] before soldering
0.94	55	35
1.09	11	7

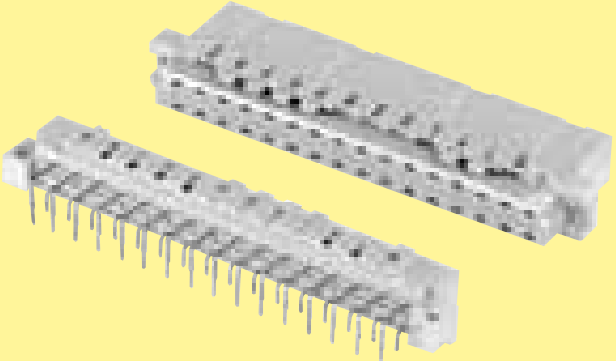
Typical measurements for a pcb of 2.4 mm thickness.

Identification	Part No.	Drawing
<p>Coding system <u>without</u> contact loss</p>	<p>Male and female connectors</p> <p>Types B, C, D and E</p> <p>see product pages or on request</p>	<p>To avoid accidental and incorrect mating of adjacent connectors a coding system is required. This coding system is an integral part of both male and female connectors. A comb with 12 coding pins, which is supplied under a single part number, allows over 900 coding variations. The pins are to be locked into the male and female connectors.</p> <p>The connectors with the integrated coding facility are supplied for types B, C, D and E and are available for all variants.</p> <p>Please contact us.</p> 
<p>Coding pins</p> <p>Mounting example</p>	<p>12 pins on a comb</p> <p>09 02 000 9928</p>	 <p>The drawing includes a perspective view of the 12 pins, a top view showing the pin arrangement, and a side view showing the comb's profile. Dimensions are provided for the comb's length and pin spacing. Labels B, C, D, Type D, E, and E are used to identify different pin configurations.</p>

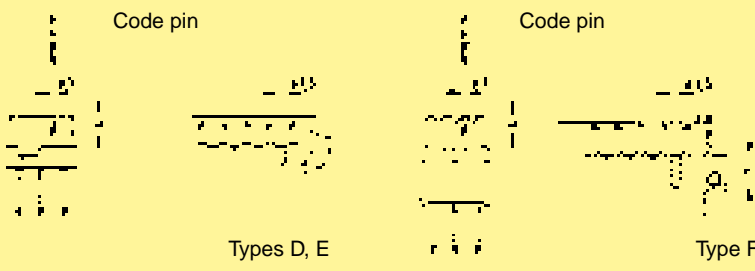
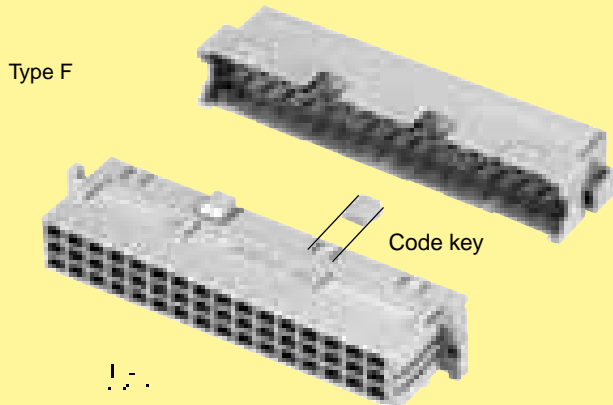
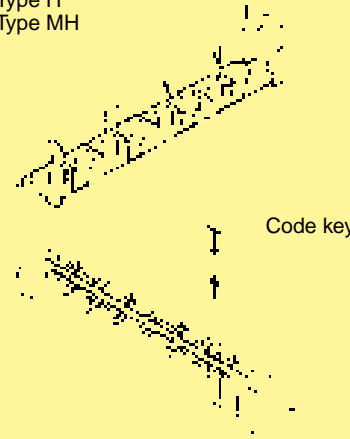
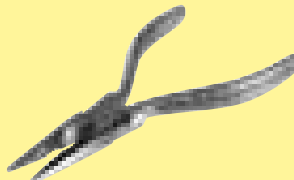
Identification	Part No.	Drawing	Dimensions in mm
<p>Coding system <u>without</u> contact loss</p> <p>with code pin</p>	<p>Code pin 09 06 000 9950</p> <p>Insertion tool 09 99 000 0103</p>	<p>With the aid of the marked indents between the contact rows of the male connector a hole has to be drilled at the desired position (also see drawing). The code pin can then be inserted into the corresponding cavity of the female connector by means of the insertion tool.</p> <p>This coding system is available only for the types D, E, F and interface connectors I.</p>  <p>Mounting example</p> 	
<p>shroud coding</p> <p>Type F</p>	<p>Code key 09 06 001 9919</p>	<p>Insert the code key into one of the keyways of the female connector as shown in the drawing. Break out the corresponding area of the male shroud.</p> <p>Connectors coded this way can only be applied in a minimum rack spacing of 20.32 mm.</p> 	
<p>shroud coding</p> <p>Types H, MH 24 + 7</p>	<p>Code key 09 06 001 9918</p>	<p>Type H Type MH</p> 	
<p>Tool for breaking out the coding area of the male shroud</p>	<p>09 99 000 0242</p>		

Identification	Part No.	Drawing	Dimensions in mm
<p>Coding system without contact loss</p> <p>flange coding</p> <p>Type MH 21 + 5</p> <p>colour red blue green orange</p> <p>colour red blue green orange</p>	<p>Code keys</p> <p>for male connectors</p> <p>09 06 001 9950 09 06 001 9951 09 06 001 9952 09 06 001 9953</p> <p>for female connectors</p> <p>09 06 001 9960 09 06 001 9961 09 06 001 9962 09 06 001 9963</p>	 <p>can be mounted with a screwdriver (max. width 3 mm)</p>	
<p>Coding system with contact loss</p>	<p>Code pin for types B, 2B, 3B, C, 2C, 3C, M, M-flat, Q, 2Q, R, R (HE 11), 2R, har-bus 64</p> <p>09 02 000 9901</p> <p>Removal tool for male contacts</p> <p>09 99 000 0133</p> <p>Code pin for types D, E, F, FM, 2F, MH</p> <p>09 04 000 9908</p> <p>Removal tool for male contacts</p> <p>09 99 000 0038</p>	<p>To avoid accidental and incorrect mating of adjacent connectors a coding system is required. The coding is achieved by means of a code pin which is inserted into the selected chamber of the female connector (the contact cavity must be filled with a female contact!). The opposite male contact must be removed with the help of the specially designed tool.</p> <p>It's recommended to use a number of code pins in relation to the total number of contacts per connector: 3 pins for 64 contacts, 7 pins for 160 contacts.</p> <p>Plastic</p> <p>Plastic</p> 	

In addition to the standard demands of connectors, as defined in IEC 60 603-2, for example, market and application specific demands and requirements are gaining increasing significance.

In the railway engineering area the demands made on reliability and safety are particularly high, in order to ensure utmost passenger safety in all instances. Especially in the case of routes involving a high share of tunnels that only offer limited escape route possibilities in the event of fire, the technical demands made on the materials employed are very stringent.

In addition to the fire load, and/or the flammability of a material, the so-called smoke gas density is a key characteristic, which is determined based on the opacity and toxicity of the smoke gas emissions. The risk posed by the two characteristics can not be defined in relationship to each other, which means that both minimal inflammability as well as minimal smoke gas density must be fulfilled. Materials that meet both requirements are very rare and in many instances it is only possible to fully meet one of the two criteria.

The French NFF 16-101 railway standard defines these requirements precisely and presents a structure of application groups by way of a matrix.

NFF 16-101 classifies non-metallic materials used in rail vehicles in terms of fire behavior, opacity and toxicity of smoke gas emissions in the event that the materials should burn.

In order to enable the classification with regard to the deployment of connectors, the following values must be applied:

1. Fire behavior class

Classification:

I0	for I.O. ≥ 70	and no inflammation at 960 °C
I1	for I.O. 45 - 69	and no inflammation at 960 °C
I2	for I.O. 32 - 44	and no inflammation at 850 °C
I3	for I.O. 28 - 31	and no afterburning at 850 °C
I4	for I.O. ≥ 20	
NC	not classified	

Note: The values are derived from specified test methods determining the oxygen value (I.O.) and testing inflammability by way of a filament.

2. Smoke development classification

Classification:

F0	for I.F. ≤ 5
F1	for I.F. 6 - 20
F2	for I.F. 21 - 40
F3	for I.F. 41 - 80
F4	for I.F. 81 - 120
F5	for I.F. > 120

Note: The values of the smoke index (I.F.) are derived from specified test methods by determining opacity (specific optical density, opacity values), toxicity (critical gas concentration of CO, CO₂, HCl, HBr, HCN, HF, SO₂ in smoke).

The matrix from NFF 16-102 shows how the combination of both characteristics results in a classification. This matrix is defined by the contractor in each project put up for bidding. The matrix is geared to the type of train and course of the route, whereby special attention is given to the number of tunnels. By complying with the high classifications I2 and F1, the designated standards supplementing connectors according to IEC 60603-2 can be used in all four defined groups and for all railway applications. According to NFF 16-102 the standard DIN connectors (I3, F3) are only permissible for Group 1.

Diagram: Classification from NFF 16-102, April 1992

The HARTING DIN Power and DIN Signal-Portfolio looks back on a highly successful track record in the railroad engineering industry. Typical application areas include – among many others - control, steering, monitoring components and modules on board trains, as well as signal technology components or the power supply of electronic components.

The extended range of connectors complying with the highest classification according to NFF 16-101 and 16-102 considerably reduce our customers' development times: as the selected connectors are suitable for every stipulated hazard or risk class, they are ideal for realizing product platforms, and therefore find use in every conceivable rail vehicle or railroad engineering project. This dispenses with the need for complex, product specific development work, at least in terms of selecting passive PCB interfaces, while the technical approval process is streamlined considerably.

In order to facilitate rapid identification the additional, railway specific articles are designated accordingly on the product pages.



THT soldering technology

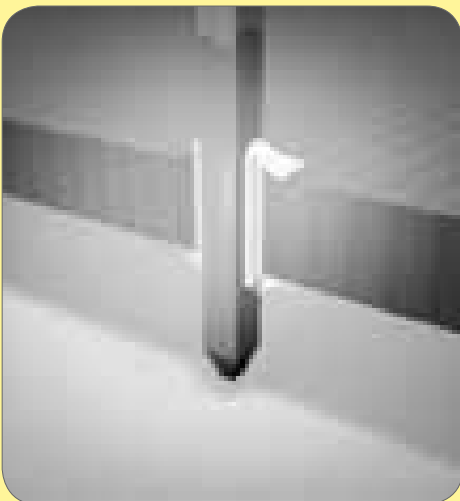

SMC soldering technology

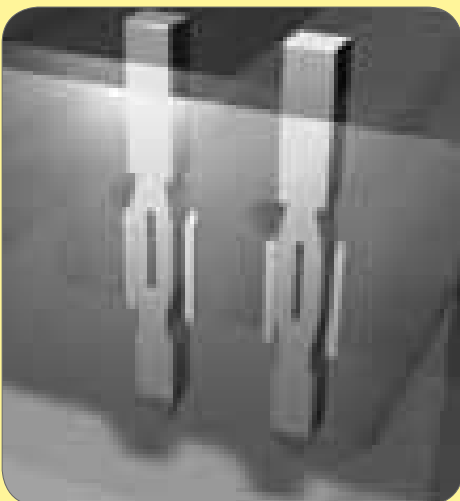

Press-in technology

THT soldering technology

Proven over decades, standard soldering technologies deliver maximum stability and process reliability. The soldering pins of the connectors are inserted into the through-plated PCB holes and can then be soldered simultaneously with other components in a wave soldering process.

SMC soldering technology

The connector is inserted into through-plated PCB holes similar to standard component assembly for processing with SMC (Surface Mount Compatible) soldering technology. Insertion of these SMT components can be automated by means of Pick & Place assembly in preparation for a reflow soldering process together with the surface-mounted component.

This connection technology is characterized by high mechanical strength and is facilitated by a design that is specially adapted to the reflow soldering process (high-temperature materials).

Press-in technology

This solder-free connection technology is based on press-in mounting of a pin in a throughplated PCB hole. The implementation of a state-of-the-art, flexible press-fit zone allows for the compensation of tolerances of PCB holes and meets high electrical and mechanical requirements for properties such as low press-in forces and high holding forces.

Press-in technology supports unlimited cost efficient processing, especially of pins with selective gold plating for backplane bus systems.

Wire wrap terminals

This solder-free connection technology is based on a wire, which is wrapped with several turns onto a rectangular post. When wires are correctly wrapped the connection performs with low resistance, mechanical strength and high reliability, unaffected by normal climatic or temperature change.

Crimp terminals

Gas-proof and the miniaturized contact technology are synonymous with crimp technology. The flexible conductor is inserted into the crimp contact and is retained by controlled deformation. This technology is similar to a cold welding process and provides maximum aging resistance and mechanical resistance to shock and vibration. Crimp machines facilitate the efficient, streamlined production of system cable assemblies, and crimp technology can also be deployed for field assemblies using the corresponding hand crimp tools. The technical requirements for crimp technology are standardized in IEC 60 352-2.



Crimp terminal

IDC insulation displacement terminals

IDC (insulation displacement contact) technology facilitates the simple and safe termination of solid and flexible conductors. With IDC technology, a blade cuts through the wire insulation and produces an elastic termination in a single pass. This gas-proof connection provides maximum safety even for the lowest currents and voltages. Technical requirements for IDC technology are standardized in IEC 60 352-3.



IDC insulation displacement terminals

Solder lug terminals

The solder lug termination is the optimized solution for production of small lot sizes and prototypes. Even without any special tooling a big variety of cables can be terminated to the cable connectors. The stripped wire is soldered individually by hand to the solder lug. This termination should however only be manufactured by experienced specialists.

Faston blades terminals

The faston blade termination is used for free wiring. Benefits are the high current carrying capacity (up to 15 A) and the easy possibility for variations.

Cage clamp terminals

The cage clamp terminal technology is used to terminate flexible and solid conductors by means of spring force. After the spring has been opened by an actuator element, the stripped conductor is simply inserted into the contact chamber. This connection technology requires minimum operating expense and is characterized by its high functional safety. The springloaded connection also allows the termination of more than one wire per contact and excels with high vibration and shock resistance.



Cage clamp terminals

THT soldering technology

The term "soldering" is defined in DIN 8505:

"Soldering is a method of connecting metallic materials using an additional melting metal, if necessary with the assistance of a flux and/or protective gas. The melting temperature of the solder must lie beneath the minimum melting temperature of the base metals being connected. These base metals shall be tinned without melting themselves."

Soft solders commonly used on electronic equipment are to DIN 1707-100. Today's lead free solders have a melting range between 217 °C and 227 °C depending on the composition of the alloy. For soldering metallic materials the flux is defined in DIN EN 29 454-1. Tests are explained in DIN 8526. For soldering male connectors into printed circuit boards, see recommendations for soldering on page 00.06.

SMC soldering technology

The continuing trend towards miniaturisation has revolutionised the assembly of electronic components. For the past 15 years, most components have been secured directly to the pcb surface by means of Surface Mount Technology (SMT). By dispensing with drilled holes on the pcb, a space saving of up to 70 percent is achieved.

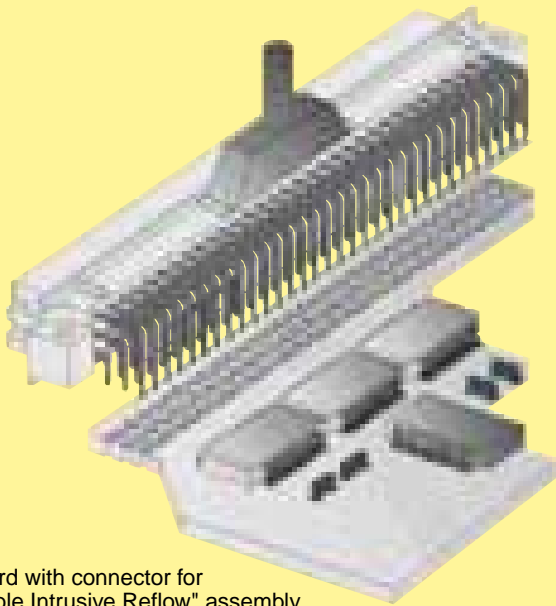

Fig. 1: SMT board with connector for "Pin in Hole Intrusive Reflow" assembly

Today, typical components such as resistors, ICs, capacitors, and connectors with straight terminal pins are almost exclusively fitted using SMD (Surface Mount Device) technology in mass production. In contrast, angled SMD connectors at the edge of the board have not been successful because of tolerance problems (co-planarity) and stresses during mating. Modified solder connectors for assembly with "Pin in Hole Intrusive Reflow" process offer a better solution. These can be mounted at low cost, utilising existing SMD production lines.

"Pin in Hole Intrusive Reflow"

In this process, the connector is inserted into plated through holes in a comparable way to conventional component mounting. All other components can be assembled on the pcb surface.

The components are positioned using pick-and-place machines. These automatic assembly machines differ according to whether the components are small, lightweight or bulky. Connectors are considered bulky (odd form) because of their comparatively heavy weight and large volume which makes them more difficult to grip. Furthermore, machines for odd form components must have higher insertion power to fit the components into pcb holes, which are filled with solder paste. As a rule, modern SMC production lines are equipped with both types of machine, therefore the "Pin in Hole Intrusive Reflow" process generally entails no extra investment costs for the user.

Conventional assembly process:

1. Application of solder paste
2. Positioning the components
3. Positioning odd form components
4. Reflow soldering
5. Pressing in or partially dip soldering the connector at the board edge
6. Quality inspection

"Pin in Hole Intrusive Reflow" assembly:

1. Application of solder paste
2. Positioning the components
3. Positioning odd form components
4. Reflow soldering
5. Pressing in or partially dip soldering the connector at the board edge
6. Quality inspection

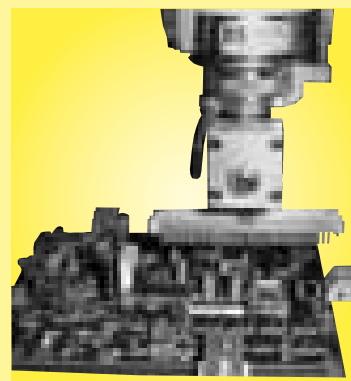

Fig. 2: Pick-and-place machine for odd form components (Courtesy of JOT Automation GmbH)

Solder requirements

Application of solder paste

Before the components are assembled, solder paste must be applied to all the solder pads (for connecting surface-mount components) and the plated through contacts (pcb holes for "Pin in Hole Intrusive Reflow" insertion). Usually a screen printing process is used for this purpose. A squeegee moves across the pcb, which is masked with screens and presses the solder paste into all unmasked areas. To ensure that the plated through holes are completely filled, significantly more solder paste must be applied than traditional solder pads on the pcb surface. The required quantity can be set exactly via several parameters.

As an alternative to screen printing, the solder paste can be applied by means of a dispenser. A high-precision robot moves the dispenser to all required positions on the pcb. The dispensing method is particularly suitable for small pcb's or applications which demand high precision and flexibility in dispensing volumes.



Fig. 3: Dispenser in operation

Requirements for the solder connection

There are numerous scientific studies dealing with calculation of the required quantity of solder paste. These studies use various parameters, e.g. the shrinking factor of the paste during soldering or the thickness of the screens used for masking the pcb. Since such calculation methods are complicated to apply, the following rule of thumb has proved valuable in practice:

$$V_{\text{Paste}} = 2(V_H - V_P)$$

in which:

V_{Paste} = Required volume of solder paste

V_H = Volume of the plated through hole

V_P = Volume of the connector termination in the hole

Comment: the multiplier "2" compensates for solder paste shrinkage during soldering. For this purpose, it was assumed that 50 % of the paste consists of the actual solder, the other 50 % being soldering aids.

At the beginning of a new production batch, the process parameters, such as quantity of solder paste and soldering temperature, can be set by interpreting simple cross-sections of the soldered connection. A reliable measure for achieving optimum parameters is the quantity of solder required to fill the hole. In soldered connections of high quality, the holes are filled to between 75 % and 100 %.

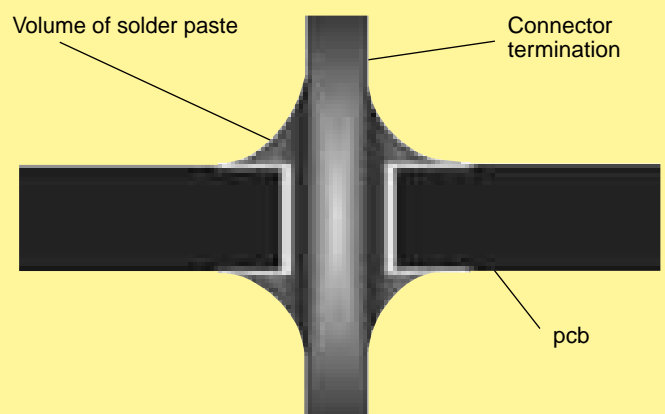

Fig. 4: Plated through hole with connector termination

Requirements for SMC connectors

SMC (Surface Mount Compatible) connectors have to withstand temperatures of up to 240 °C in the reflow oven for 10 to 15 seconds. Therefore, the moulding must be made from a dimensionally stable plastic which expands at the same rate as the pcb material when subjected to heat.

The length of the connector contacts should be such that they protrude by no more than 1.5 millimetres after insertion to the pcb. Each contact collects solder on its tip as it penetrates the solder paste in the hole. So if the contact was too long, this solder would no longer be able to reflow back into the plated through hole by capillary action during the soldering process, therefore the quality of the soldered connection would suffer as a result.

Connector design must permit both automatic assembly with pick-and-place machines and manual positioning for test and pre-production batches. It is also important for the packaging of the connectors to be suitable for automated assembly. Experience shows that deep-drawn film and reel packaging fed into the pick-and-place machines with the aid of a conveyor system is particularly suitable.

HARTING SMC technology

HARTING offers its customers a complete system concept for integrating SMC technology into existing production lines. We manufacture a wide range of SMC connectors (3 and 5 row) in compliance with IEC 60603-2, D-Sub connectors in compliance with IEC 60807 and connectors from the har-mik® series with contact spacing of 1.27 millimetres. In addition, HARTING supports the market with packaging and processing concepts, which have been developed in collaboration with renowned manufacturers of SMC soldering and assembly plants.

Advantages of the “Pin in Hole Intrusive Reflow” process:

- Partial dip soldering or press fitting is no longer required
- Complete compatibility with Surface Mount Technology
- Complete integration into the automated assembly process
- Reduced floor space in the production plant
- As a rule, no additional investment costs



Fig. 5: HARTING connector mounted in a tape ready for placement using an odd form assembly station.

harpress Press-in technology

Solderless termination for connectors has proven to be reliable for decades. Today the use of press-in connectors encompasses all fields of electrical and electronical applications.

Pressing of electrical components, mainly connectors, is characterised through the matching of the connector pin and the plated through hole of the pcb. Whereas the desired electrical characteristics can be attained relatively independent of the design of the press-in zone, the mechanical characteristics of the press-in zone are crucial for the reliable assembly of connectors where pcb's have different surfaces.

Although the scope of requirements at the press-in process is generally defined in time-tested specifications, the novel press-in zones should offer an optimal handling and a reliable termination. Essentially, this is guaranteed through the design of the press-in zone and the meticulous observance of tolerances. HARTING has been using FEM simulations for the calculation and optimisation of press-in zones for a long period of time. This expertise allows us to simulate various pcb configurations very accurate.

Benefits of the press-in technology

- Thermal shocks associated with the soldering process and the risk of the board malfunction are avoided.
- No need for the subsequent cleaning of the assembled pcb's
- Additional wrap connections are made possible by using connectors with long pins
- Unlimited and efficient processing of partially gold-plated pins for rear I/O - manual soldering is no longer necessary!

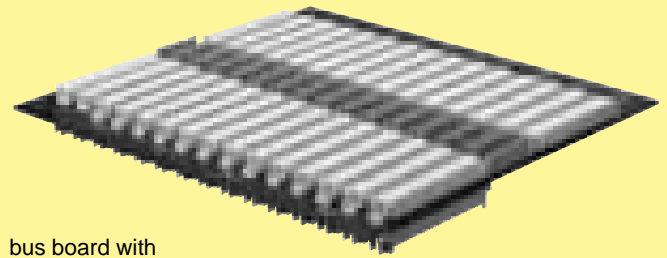

bus board with press-in connectors

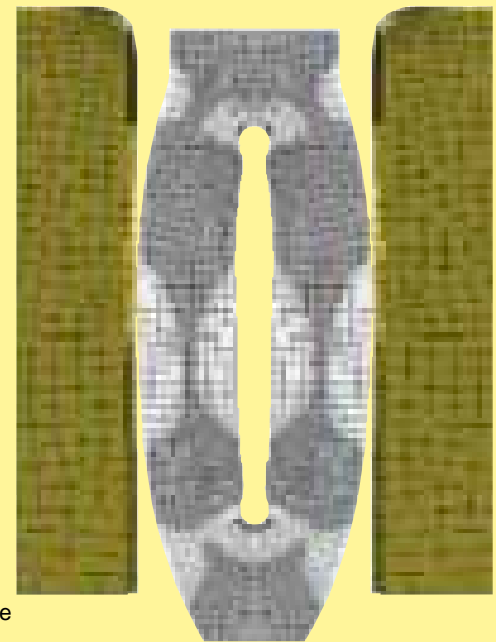

FEM simulation of the needle eye press-in zone

harpress Press-in technology

The processing of press-in connectors can be divided into 3 phases, containing both mechanical and metallurgical operations:

1. Centering and placing of the termination pins

The centering of connectors before pressing is important in order to prevent damage to the pcb and the termination pins. Centering can be omitted when connectors are pressed using a flat rock die.

HARTING offers insert blocks for male connectors to make the centering of connectors unnecessary.

2. Pressing in the pins

In the press-in process the insertion force is continuously transformed into compression force. The resulting friction frees the contacting bars of insulating films. Superfluous plating (tin) is transferred within the plated through hole. A gas-tight connection of fresh non-oxidised metal surfaces is obtained.

3. Obtaining the final position

The press-in operation should be terminated as soon as the connector obtains its final position on the pcb to avoid unnecessary compressive stress. The press-in machines of HARTING feature automatic termination of the press-in operation independent of pcb thickness and surface properties.

The entire dynamic press-in process is characterised through changes of the press-in force that can be statistically evaluated. HARTING records the changes of force with the help of special software. This is an important step towards permanent process control and documented manufacturing data.

The **harpress**-zone is based on the industry renowned needle eye technology. Its special design allows for compensation of tolerances of pcb surface properties (eg. superfluous tin plating). The excessive material is displaced within the plated through hole, whereby a gas-tight and corrosion resistant electrical connection is assured.

Phase 1

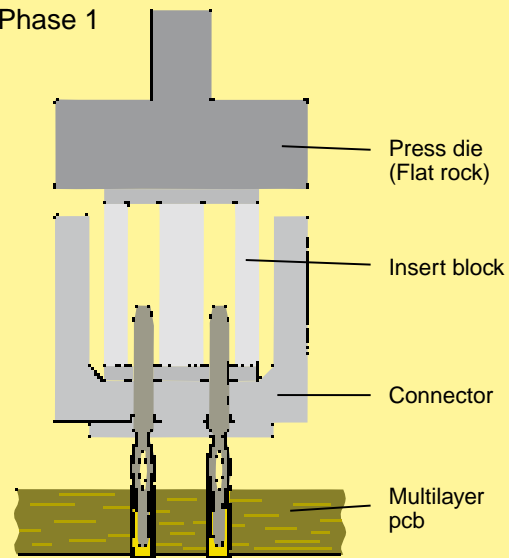

Phase 2

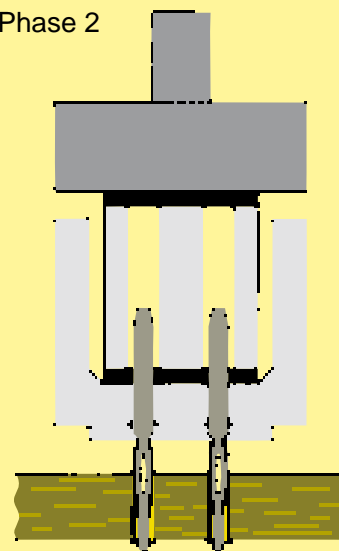

Phase 3

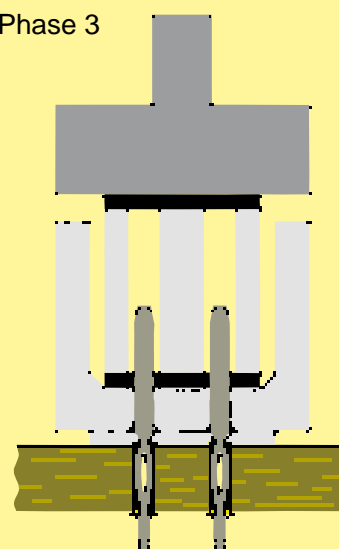

Recommended configuration of plated through holes

Due to the high deformation resistance and resilience of **press** contacts, they can be easily and repeatedly removed in case of repairs without impairment to their functioning.

press is extremely versatile and offers a reliable electrical contact, therefore it is especially well suited for applications with these surfaces.

Please contact us for detailed test reports.

In addition to the hot-air-level (HAL) other pcb surfaces are getting more important. Due to their different properties, such as mechanical strength and coefficient of friction we recommend the following configuration of pcb through holes.

<i>Tin-lead plated PCB (HAL) acc. EN 60 352-5</i>	Hole-Ø	1.15±0.025 mm
	Cu	min. 25 µm
	Sn	max. 15 µm
	Plated hole-Ø	0.94-1.09 mm

<i>Chemical tin-plated PCB</i>	Hole-Ø	1.15±0.025 mm
	Cu	min. 25 µm
	Sn	min. 0.8 µm
	Plated hole-Ø	1.00-1.10 mm

<i>Au / Ni plated PCB</i>	Hole-Ø	1.15±0.025 mm
	Cu	min. 25 µm
	Ni	3-7 µm
	Au	0.05-0.12 µm
	Plated hole-Ø	1.00-1.10 mm

<i>Silver plated PCB</i>	Hole-Ø	1.15±0.025 mm
	Cu	min. 25 µm
	Ag	0.1-0.3 µm
	Plated hole-Ø	1.00-1.10 mm

<i>OSP copper plated PCB</i>	Hole-Ø	1.15±0.025 mm
	Cu	min. 25 µm
	Plated hole-Ø	1.00-1.10 mm

PCB board thickness: ≥ 1.6 mm

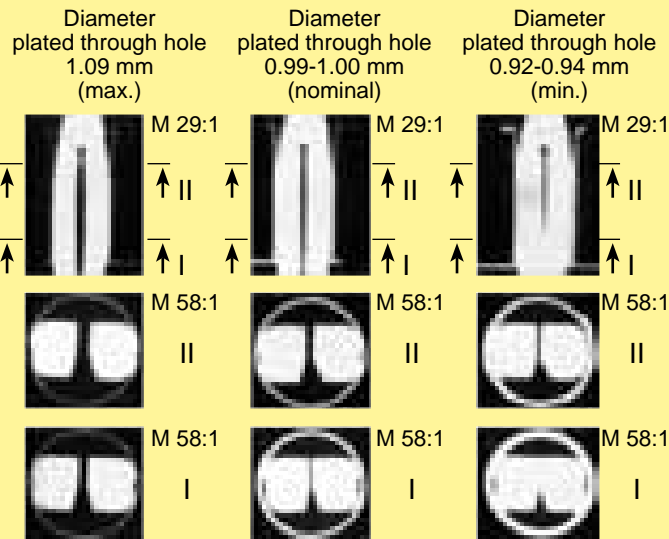

Cross section of a pcb 2.4 mm thick with various hole diameters

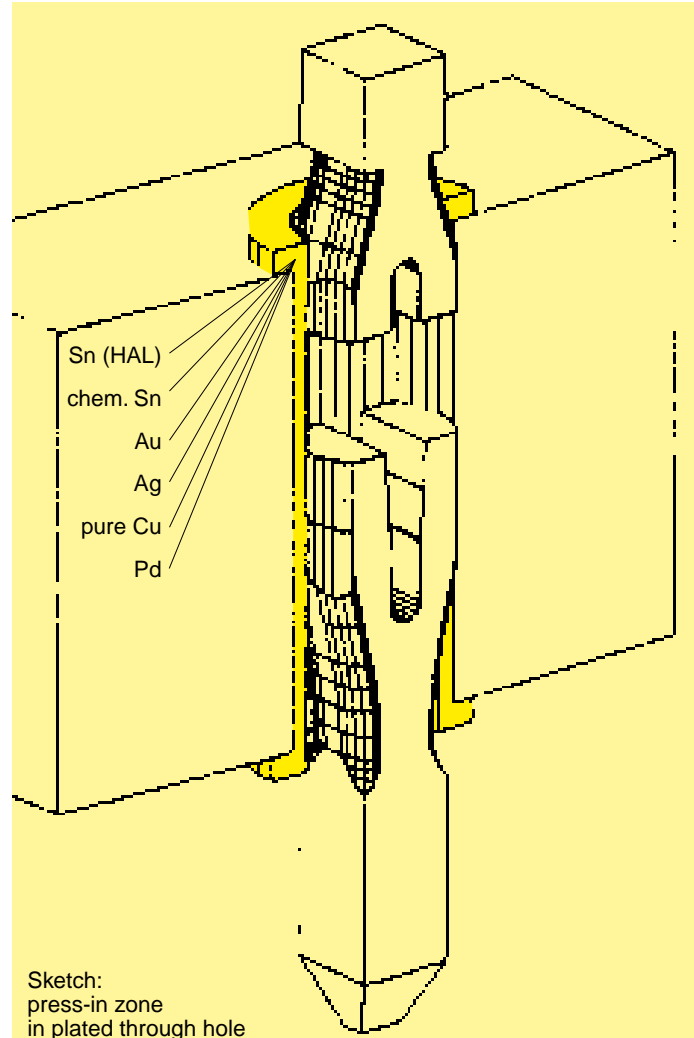

Sketch: press-in zone in plated through hole

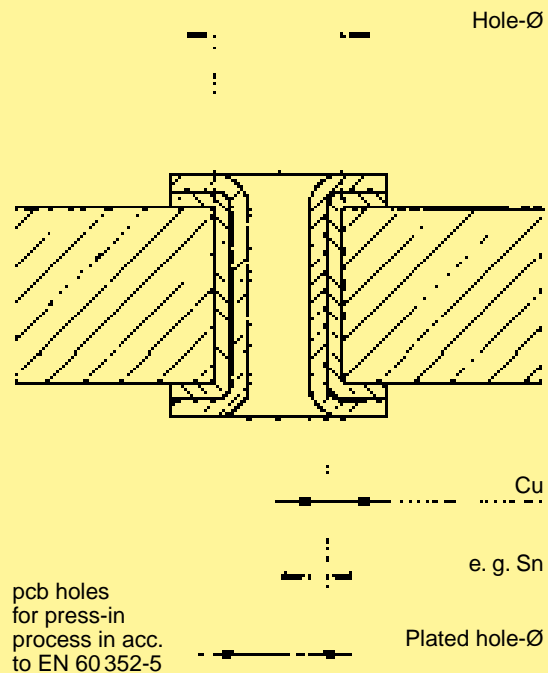

pcb holes for press-in process in acc. to EN 60 352-5

Crimp terminals

A perfect crimp connection is gastight and therefore corrosion free. It is equivalent to a cold weld of the connected parts. For this reason, major features in achieving high quality crimp connections are the design of the crimping areas of the contact and of course the crimping tool itself. Wires to be connected must be carefully matched to the correct size of crimp contacts. If these basic requirements are met, users will be assured of highly reliable connections with a low contact resistance and a high resistance against corrosion.

The economical and technical advantages are:

- Constant contact resistance as a result of an unvariable crimp connection quality
- Corrosion free connections as a result of cold weld action
- Preparation of harnessing with crimp contacts already fitted
- More economic cable connection

Requirements for crimp connections are set out in DIN IEC 60352-2.

Pull out force of stranded wire

The main criterion by which to judge the quality of a crimp connection is the retention force achieved by the wire conductor in the terminal section of the contact. DIN IEC 60352, part 2, defines the extraction force in relation to the cross-section of the conductor. When fitted using HARTING crimping tools and subject to their utilization in an approved manner, our crimp connectors comply with the required extraction forces.

Crimping tools

Crimping tools (hand operated or automatic) are carefully designed to guarantee a symmetrical deformation of the crimping area of the contact and the wire through the high pressure forming parts of the tool. The locator automatically engages the crimp contact and the wire at the correct point in the tool. The wire insulation can also be included as a secondary feature of some crimp contacts to care for additional mechanical strength.

The ratchet in the tool performs 2 functions:

- ① It prevents insertion of the crimp into the tool for crimping before the jaws are fully open
- ② It prevents the tool from being opened before the crimping action is completed

A quality crimp connection can be achieved with this crimping system. The adjacent sketches show important features of the HARTING hand crimping tool.

The HARTING automatic crimping tool uses bandoliered contacts.

The machine strips insulation from the wire and then crimps the contact. Both the crimping area and the insulation support are independently adjustable to facilitate the use of any wire type with dimensions within the stated crimp capacity.



Crimp cross-section

Tensile strength of crimped connections

Conductor cross-section		Tensile strength
mm ²	AWG	N
0.05	30	6
0.08	28	11
0.12	26	15
0.14		18
0.22	24	28
0.25		32
0.32	22	40
0.5	20	60
0.75		85
0.82	18	90
1.0		108
1.3	16	135
1.5		150
2.1	14	200
2.5		230
3.3	12	275
4.0		310
5.3	10	355
6.0		360
8.4	8	370
10.0		380

Extract from DIN IEC 60 352-2, Amend. 2, table IV

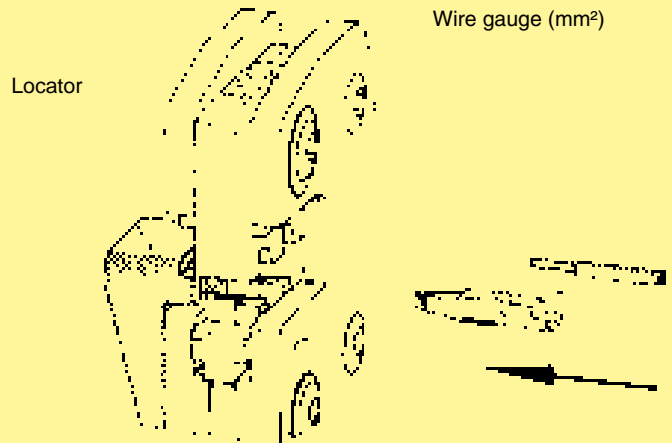

Wire wrap terminals

This technique permits high wiring density and takes over where other techniques would take up too much real estate. As a result of this process, there is a great time saving factor and cost per connection is relatively low when large numbers of connections are to be made.

When wires are correctly wrapped onto a precision manufactured rectangular post produced to the recommended specifications, one can state the following:

A low resistance, mechanically strong and highly reliable connection is made which is unaffected by normal climatic or temperature changes.

Production of wrapped connections and associated material are defined in DIN EN 60352-1.

Wrapping techniques

Standard wrap

Only the non-insulated part of the wire is wrapped around the post. This means that the size of the wrapped connection is kept to the very minimum.

Modified wrap

The top part of the wrapped connection is made using the cable conductor as stated above but an extra turn is made at the bottom. For this turn insulation is also wrapped around the post to give a great mechanical strength to the joint and also to provide insulation between adjacent posts.

Wrapping tools

To produce quality wrapped connections one must use a special wrapping tool, which can be pneumatic, electric or hand operated. Such tools have interchangeable wrapping heads and sleeves to suit the particular size of the wrap post being used.

The choice of accessories for these wrapping tools depends from the wrapping technique, the size of the wrap post itself and the conductor and insulation diameters of the wire.

The adjacent tables show the maximum amount of wrapped connections that can be placed on the wire wrap post (in acc. to IEC 60352-1).

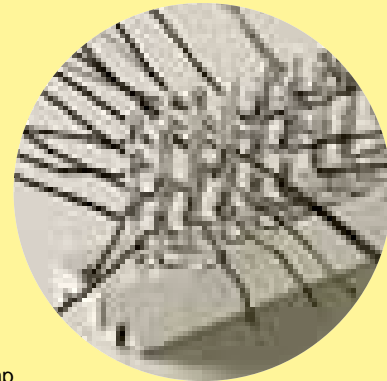

Standard wrap

		Wire diameter [mm]							
		0.25	0.32	0.4	0.5	0.65	0.8	1.0	
		max. allowed wire Ø incl. wire insulation [mm]							
		0.7	0.9	1.17	1.27	1.32	1.5	1.78	
		min. necessary turns per wrap connection (for non-insulated wire)							
		7	7	6	5	4	4	4	
Valid for standard wrap	Dimension of wire wrap post [mm]	possible wrap connections per wrap post							
	Length of wire wrap post [mm]								
	0.6 x 0.6	13	6	5	4	4	4	3	2
	0.6 x 0.6	17	8	6	6	5	5	4	3
	1 x 1	20	10	7	7	6	6	5	4
	1 x 1	22	11	8	7	7	6	5	4

Table 00.05



Modified wrap

		Wire diameter [mm]							
		0.25	0.32	0.4	0.5	0.65	0.8	1.0	
		max. allowed wire Ø incl. wire insulation [mm]							
		0.7	0.9	1.17	1.27	1.32	1.5	1.78	
		min. necessary turns per wrap connection (for non-insulated wire)							
		7	7	6	5	4	4	4	
Valid for modified wrap	Dimension of wire wrap post [mm]	possible wrap connections per wrap post							
	Length of wire wrap post [mm]								
	0.6 x 0.6	13	4	3	2	2	2	2	1
	0.6 x 0.6	17	5	4	3	3	3	2	2
	1 x 1	20	6	4	4	3	3	3	2
	1 x 1	22	6	5	4	4	4	3	2

Table 00.06





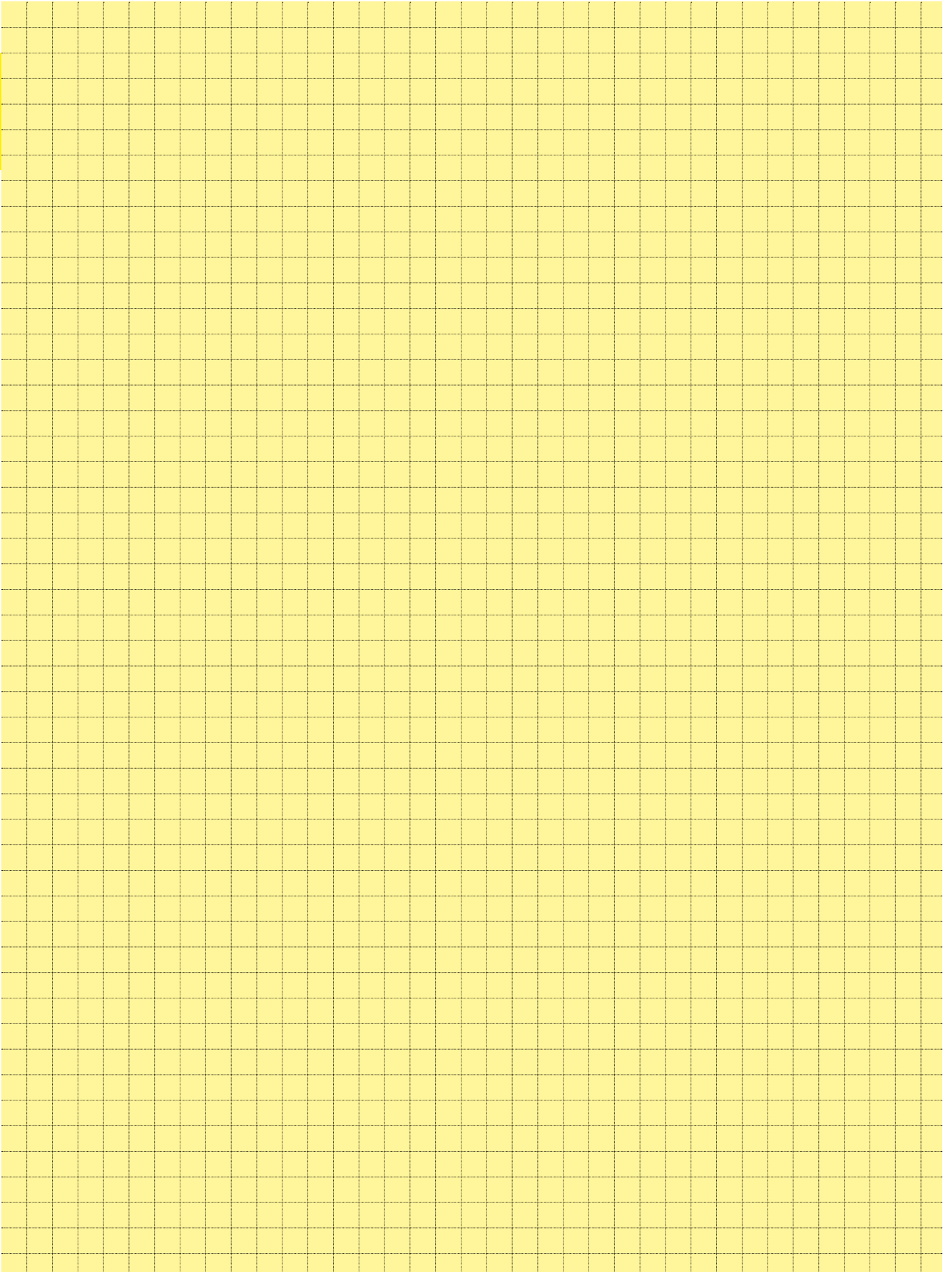







General
information

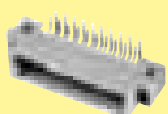
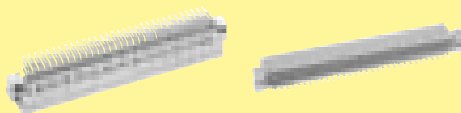

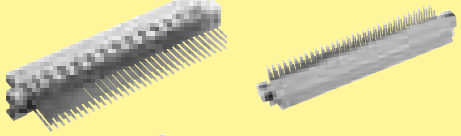
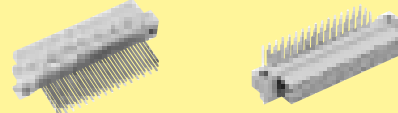

Types B, 2B, 3B, C, 2C, 3C, M, M invers, Q, 2Q, R, 2R

Page

Technical characteristics		01.10
Type B connectors		01.11
Type 2B connectors		01.16
Type 3B connectors		01.18
Type C connectors		01.20
Type 2C connectors		01.27
Type 3C connectors		01.32
Special contacts type M		01.36
Type M connectors		01.41
Type M-flat connectors		01.43
Type M invers connectors		01.44
Type R, RM, R (HE 11) connectors		01.46
Type Q, 2Q and 2R connectors		01.52
Pin shroud, adapter		01.57
Application examples		01.60

DIN Signal
up to 2 A



Number of contacts	16-96
Contact spacing (mm)	2.54
Working current see current carrying capacity chart	2 A max. 1 A with insulation displacement 40 A max. type M
Clearance	≥ 1.2 mm
Creepage	≥ 1.2 mm
Working voltage The working voltage also depends on the clearance and creepage dimensions of the pcb itself, and the associated wiring	according to the safety regulations of the equipment Explanations see chapter 00
Test voltage $U_{r.m.s.}$	1 kV
Contact resistance	≤ 20 mΩ
Insulation resistance	≥ 10 ¹² Ω for standard articles ≥ 10 ¹¹ Ω for special NFF articles (with part-no. ending 222)
Temperature range The higher temperature limit includes the local ambient and heating effects of the contacts under load During reflow soldering	- 55 °C ... + 125 °C - 40 °C ... + 105 °C for press-in connector max. + 240 °C for 15 s for SMC connectors
Degree of protection for crimp terminal	IP 20 according to DIN 40 050
Electrical termination Male and female connector	Solder pins for pcb connections Ø 1.0 ± 0.1 mm according to IEC 60 326-3 wrap posts 0.6 x 0.6 mm diagonal 0.79-0.86 mm Crimp terminal 0.09-0.5 mm ² Insulation displacement connection AWG 28/7
Compliant press-in terminations PCB thickness Recommended PCB holes for press-in technology	≥ 1.6 mm See recommendation page 00.25 in acc. to EN 60 352-5
Insertion and withdrawal force	16way ≤ 15 N 20way ≤ 20 N 30way ≤ 30 N 32way ≤ 30 N 48way ≤ 45 N 64way ≤ 60 N 96way ≤ 90 N
Materials Mouldings	Thermoplastic resin, glass-fibre filled, UL 94-V0
Contacts	Copper alloy
Contact surface Contact zone	Selectively plated according to performance level ¹⁾
¹⁾ Explanation performance levels see chapter 00	
Mating conditions see chapter 00	

Current carrying capacity

The current carrying capacity is limited by maximum temperature of materials for inserts and contacts including terminals. The current capacity curve is valid for continuous, non interrupted current loaded contacts of connectors when simultaneous power on all contacts is given, without exceeding the maximum temperature.

Control and test procedures according to DIN IEC 60 512

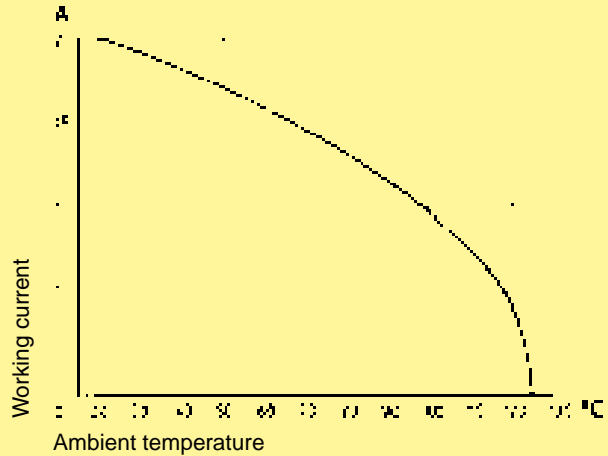

Pin shroud for male and female connectors with 0.6 x 0.6 mm pins

A secure interfacing system for signals from the rear of 19" racks to connectors with wrap posts 0.6 x 0.6 mm is possible with the use of a pin shroud.

The pin shroud protects the wrap posts on the rear side of the rack and can be screwed to the printed circuit board (screw fixing) or can be pressed onto the pins (press-in fixing).

After assembly the rear ends of the wire wrap posts become the mating areas of a type C resp. type 2C male connector.

This system can now accept:

- female connectors type C
- female connectors type 2C
- female connectors type R
- female connectors type 2R

The locking levers provide security for the mated connectors. Fast and simple disconnection is possible (see application examples, pages 01.60 ff).

Fitting and removing crimp contacts

see technical characteristics chapter 02

Number of contacts

64, 32

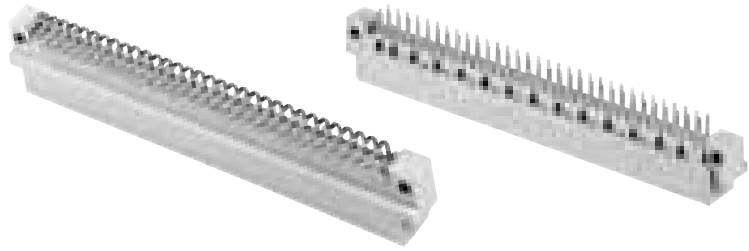

Male connectors

DIN Signal
up to 2 A

Identification	Number of contacts	Contact arrangement	Part No. Performance levels according to IEC 60603-2. Explanation chapter 00		
			3	2	1
Male connector with angled solder pins	64		09 02 164 7921	09 02 164 6921 09 02 164 6921 222 ^{f)} 09 02 364 6921 ^{b)} 09 02 664 6921 ^{c)}	09 02 164 2921
	32		09 02 132 7921	09 02 132 6921 09 02 632 6921 ^{c)}	09 02 132 2921
	32		09 02 132 7931	09 02 132 6931 09 02 332 6931 ^{b)}	09 02 132 2931
	62 + 2 [▲]			09 02 164 6951	
	SMC 64			09 02 164 7919 ^{d)}	09 02 164 6919 ^{d)}
Male connector with straight solder pins	64		09 02 164 7922	09 02 164 6922	09 02 164 2922
	32		09 02 132 7922	09 02 132 6922	
	32			09 02 132 6932	
	62 + 2 [▲]			09 02 164 6952	09 02 164 2952
	SMC 64			09 02 164 6920 ^{d)}	
Dimensions	<p>Angled solder pins Straight solder pins</p>				
Board drillings Mounting side	<p>Cross section of solder terminations</p> <p>Cross area (A) of contacts row a, b: A = 0.25 - 0.33 mm²</p> <p>Dimensions in mm</p>				

▲ Male connectors with 2 leading contacts [(0.8 mm) pos. a1 and a32]. Lagging pins on request.
Other contact arrangements on request
b) Connectors with snap-in clips see chapter 00

c) Connectors with coding see chapter 00
d) CTI > 400
f) Railway classification NFF 16-101, Smoke index: F1, Flammability class: I2

Number of contacts

64

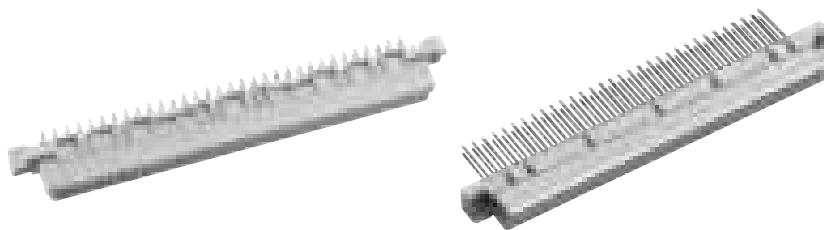

Female connectors

DIN Signal
up to 2 A

Identification	Number of contacts	Contact arrangement	Part No.	Performance levels according to IEC 60603-2. Explanation chapter 00	
			3	2 1	
Female connector with solder pins 2.9 mm	64		Performance level 3 on request	09 02 264 6824 09 02 464 6824 ^{b)} 09 02 764 6824 ^{c)}	09 02 264 2824
	SMC 64			09 02 264 6841 ^{d)}	
Female connector with solder pins 4.5 mm	64			09 02 264 6825 09 02 264 6825 222 ^{f)} 09 02 464 6825 ^{b)} 09 02 764 6825 ^{c)}	09 02 264 2825
	SMC 64			09 02 264 6829 ^{d)}	
Female connector with solder pins 13 mm	64			09 02 264 6421	
Female connector with press-in pins 4.5 mm	64			09 02 264 6850 09 02 264 6850 222 ^{f)}	09 02 264 2850
Female connector with press-in pins without flange 5.3 mm	64			09 02 264 6870	
Female connector with press-in pins 13.2 mm	64			09 02 264 6861 ^{a)}	
Female connector with wrap posts ¹⁾ 13 mm	64			09 02 264 6821	
Female connector with solder lugs 5.2 mm	64		09 02 264 6823		

01
12

1) To be used only for wire wrap termination
 a) Wrap posts selectively gold plated (performance level 3)
 b) Connectors with snap-in clips see chapter 00
 c) Connectors with coding see chapter 00

d) CTI > 400
 f) Railway classification NFF 16-101, Smoke index: F1, Flammability class: I2
 Other contact arrangements on request

Number of contacts

64

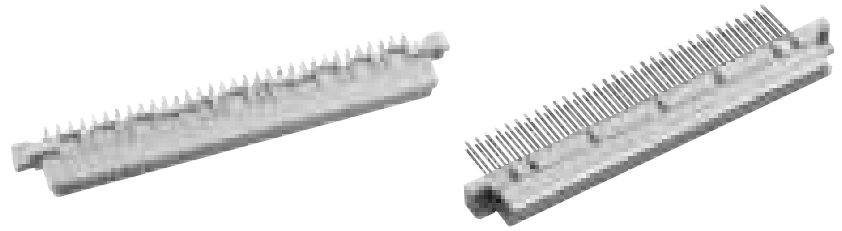

Female connectors

Identification

Drawing

Dimensions in mm

Dimensions

a	
2.9	Solder pins
4.5	
13	Press-in pins
4.5	
5.3	Wrap posts
13.2	
13	Solder lugs
5.2	

Panel cut out

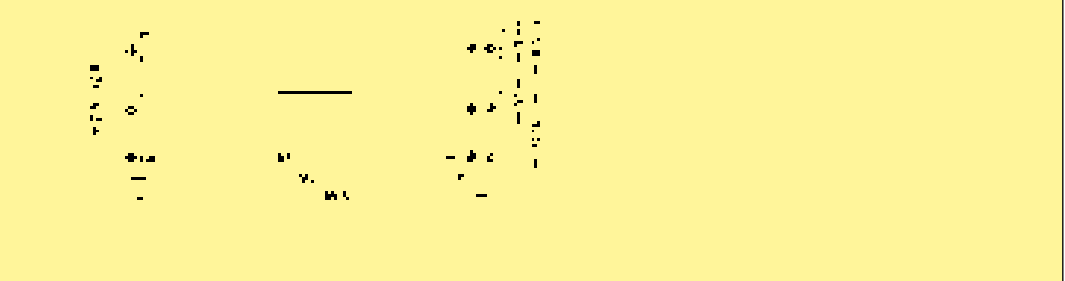

Board drillings
Mounting side

	Y
Solder	1 ± 0.1
Press-in	see recommendation page 00.25

Identification strips for female connectors with wrap posts 09 02 000 9939

Cross section of solder terminations

a	P	Q	A
2.9	0.75 _{-0.05}	0.30 _{±0.01}	0.20 - 0.23 mm ²
4.5	0.75 _{-0.05}	0.30 _{±0.01}	0.20 - 0.23 mm ²
13	0.60 _{-0.02}	0.60 _{-0.02}	0.33 - 0.38 mm ²

Cross area (A) of contacts

DIN Signal up to 2 A

Number of contacts

64

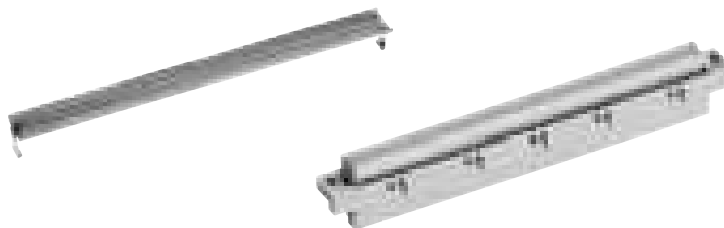

Female connectors

DIN Signal up to 2 A

Identification	Number of contacts	Part No.	Drawing	Dimensions in mm
Female connector for insulation displacement	64	Performance level 2 ¹⁾ 09 02 264 6828 Performance level 3 ¹⁾ 09 02 264 7828	 Cable 1 Cable 1 Cable 1 to contact 1 b Contact arrangement View from termination side	
Strain relief (metal)		09 03 000 9940		
Panel cut out				
Flat cable AWG 28/7 grey 30.48 m grey 100.00 m colour coded 30.48 m twisted pair ²⁾ 30.48 m	64 64 64 64	09 18 064 7001 09 18 064 7004 09 18 064 7005 09 18 064 7006	 grey 1 27 12 02 C 53 10 02 17 - 1 - 127 -	²⁾ Termination area spacing = 508 mm Important: always store reels vertically Wire (tinned) Cu Gauge AWG 28/7 0.089 mm ² Insulation material as per UL style PVC
Round flat cable ³⁾ with screening 30.48 m 100.00 m without screening 30.48 m 100.00 m	64 64 64 64	09 18 064 7007 09 18 064 7010 09 18 064 7008 09 18 064 7011	 Edge mark on first conductor AWG 28/7 grey	³⁾ Termination area spacing = 100 mm
Bench press Base plate		09 99 000 0114 09 99 000 0150		
Cable cutter		09 99 000 0116		
Spare parts Blade Cutting plate		09 99 000 0179 09 99 000 0180		

Number of contacts

max. 64

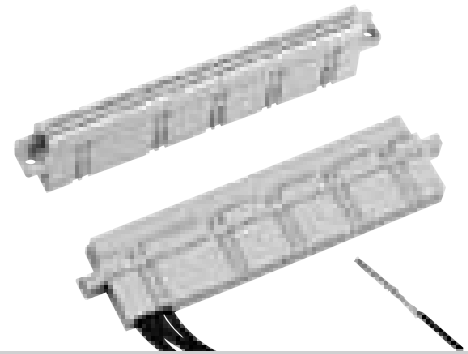

Female connectors

DIN Signal up to 2 A

Identification	Number of contacts	Part No.	Drawing	Dimensions in mm
Female connector for crimp contacts Order contacts separately	64	09 02 064 3214 ¹⁾	<p>Contact arrangement View from termination side</p>	
Shell housing 09 02 064 0501 / 09 02 064 0502 see chapter 20				

Identification	Part No.	Performance levels according to IEC 60603-2. Explanation chapter 00	
		2	1
Female crimp contacts BC			
Bandoliered contacts (approx. 5,000 pieces)	09 02 000 6484		09 02 000 6474
Bandoliered contacts (approx. 500 pieces)	09 02 000 8434		09 02 000 8444
Individual contacts ¹⁾	09 02 000 8484		09 02 000 8474
	Wire gauge mm ² AWG Insulation ø mm 0.09 - 0.5 28 - 20 0.7 - 1.5		<p>Bandoliered contacts</p>
	3.5 + 0.5 mm of insulation is stripped from the wires to be crimped For the fabrication in line with the specification please use exclusively crimp tools approved by HARTING (see DIN EN 60352-2) Insertion, removal and crimping tools see chapter 30		<p>Individual contacts</p>

¹⁾ Packaging unit 1,000 pieces

¹⁾ Railway classification NFF 16-101, Smoke index: F1, Flammability class: I2



Number of contacts

32, 16

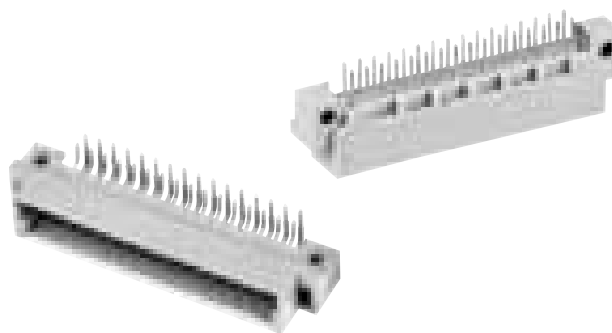

Male connectors

DIN Signal up to 2 A

Identification	Number of contacts	Contact arrangement	Part No.	Performance levels according to IEC 60603-2. Explanation chapter 00		
				3	2	1
Male connector with angled solder pins SMC	32		09 22 132 7921	09 22 132 6921 09 22 132 6921 222 ^{f)} 09 22 332 6921 ^{b)}	09 22 132 2921	
	32			09 22 132 6919 ^{d)} 09 22 332 6919 ^{b)d)}		
	16			09 22 116 6921		
	16		09 22 116 7931	09 22 116 6931		
	30 + 2 [▲]			09 22 132 6951		
Male connector with straight solder pins SMC	32		09 22 132 7922	09 22 132 6922	09 22 132 2922	
	32			09 22 132 6920 ^{d)}		

Dimensions

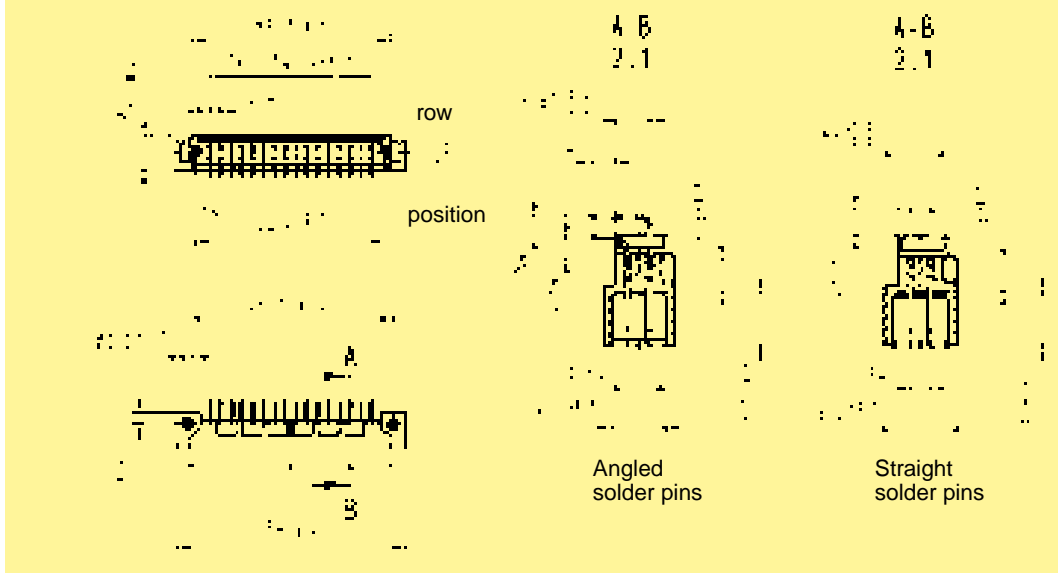

Board drillings
Mounting side

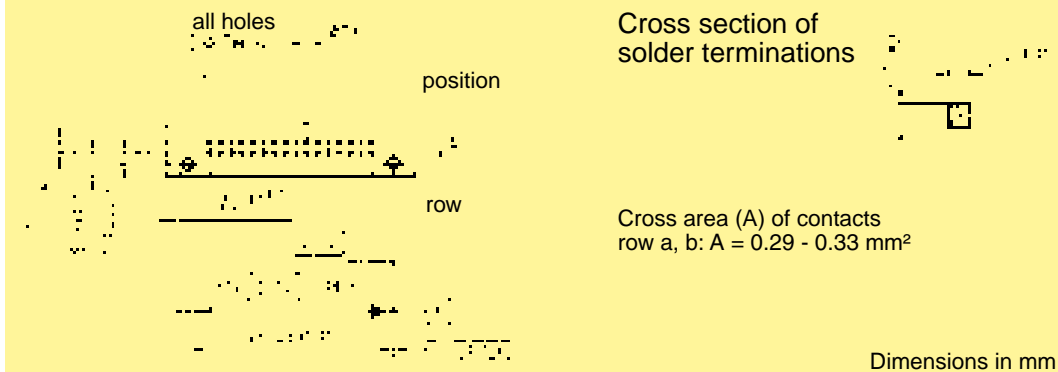

01
16

[▲] Male connectors with 2 leading contacts [(0.8 mm) pos. a1 and a16]. Lagging pins on request.

^{b)} Connectors with snap-in clips see chapter 00

^{d)} CTI > 400

^{f)} Railway classification NFF 16-101, Smoke index: F1, Flammability class: I2

Other contact arrangements on request

Number of contacts

32

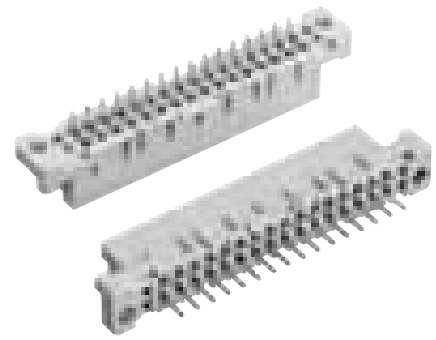

Female connectors

Identification	Number of contacts	Contact arrangement	Part No.	Performance levels according to IEC 60603-2. Explanation chapter 00		
				3	2	1
Female connector with solder pins 2.9 mm SMC	32		Performance level 3 on request	09 22 232 6824	Performance level 1 on request	
	32			09 22 432 6824 ^{b)}		
	32			09 22 232 6841 ^{d)}		
4.5 mm SMC	32			09 22 232 6825		
	32			09 22 232 6825 222 ^{f)}		
13 mm	32		09 22 432 6825 ^{b)}			
Female connector with wrap posts ¹⁾ 13 mm	32		09 22 232 6829 ^{d)}	09 22 232 6421		
	32		09 22 232 6821			
Female connector with press-in pins 4.5 mm	32		09 22 232 6850			

DIN Signal up to 2 A

Dimensions

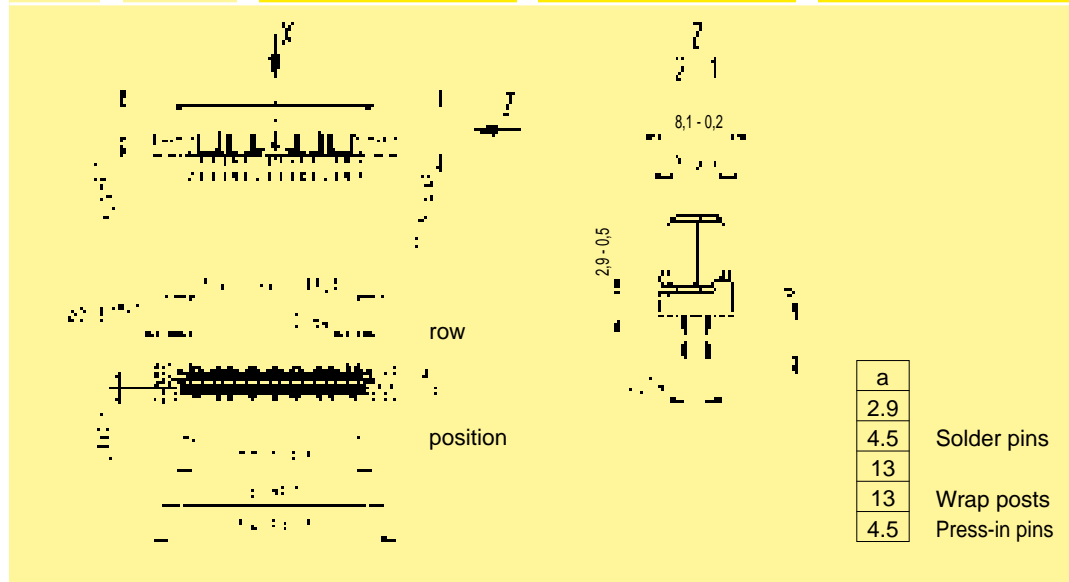

Board drillings
Mounting side

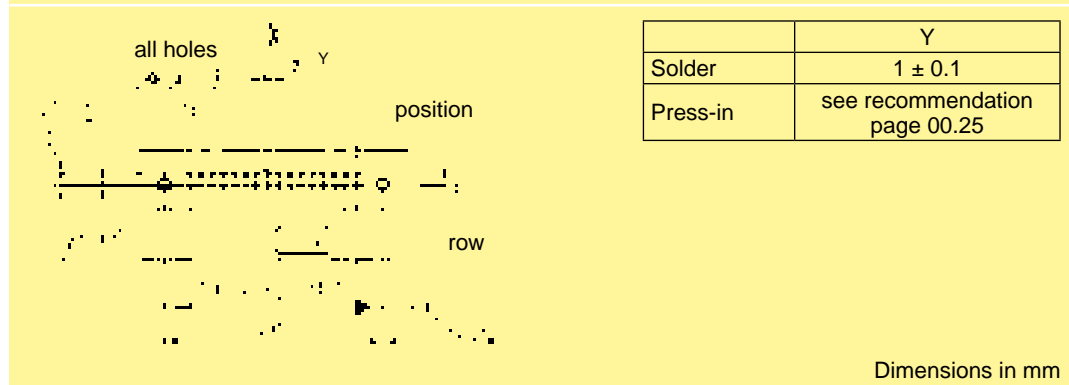

Cross section of solder terminations
see page 01.13

Dimensions in mm

¹⁾ To be used only for wire wrap termination
^{b)} Connectors with snap-in clips see chapter 00
^{d)} CTI > 400

^{f)} Railway classification NFF 16-101, Smoke index: F1, Flammability class: I2
 Other contact arrangements on request

Number of contacts

20

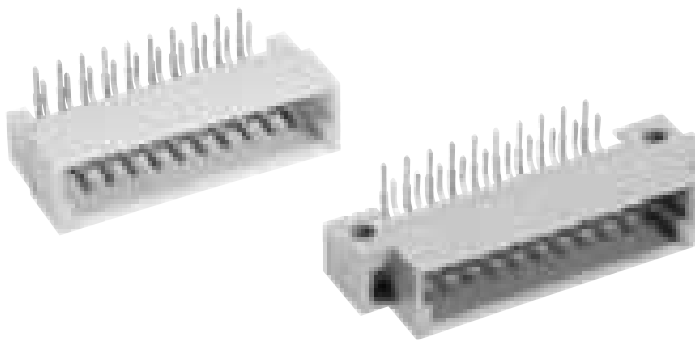

Male connectors

DIN Signal up to 2 A

Identification	Number of contacts	Contact arrangement	Part No.	Performance levels according to IEC 60 603-2.		
			3	2	1	
Male connector with angled solder pins with fixing flange	20		Performance level 3 on request	09 24 120 6921		
with fixing flange, SMC	20			09 24 120 6919 ^{d)}		
without fixing flange	20			09 24 120 6571		Performance level 1 on request
without fixing flange, SMC	20			09 24 120 6579 ^{d)}		
Male connector with straight solder pins with fixing flange	20			09 24 120 6922		

Dimensions

with fixing flange without fixing flange

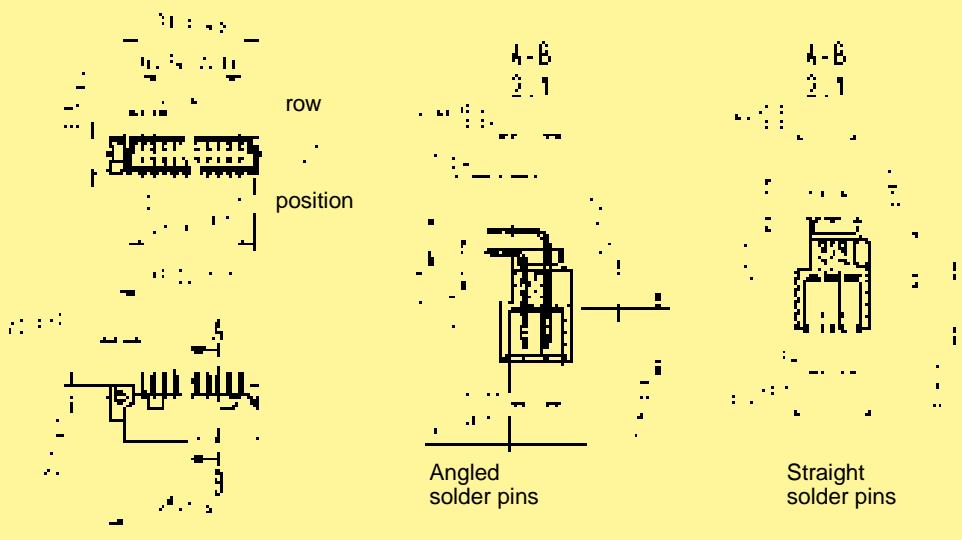

Board drillings

Mounting side

all holes

Cross section of solder terminations

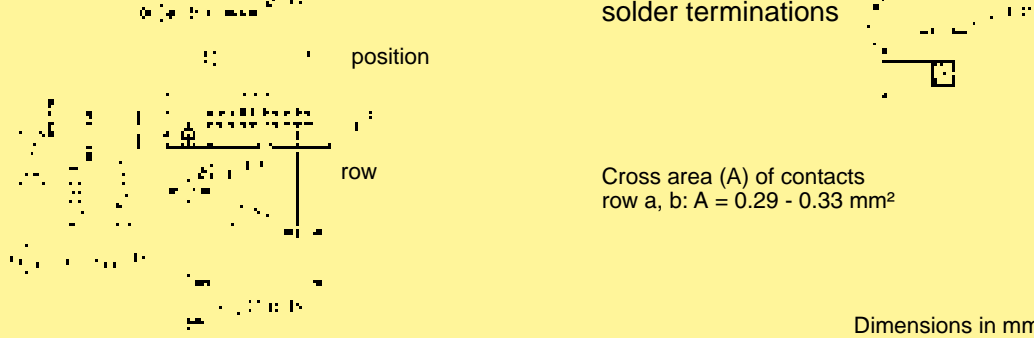

Dimensions in mm

Number of contacts

20

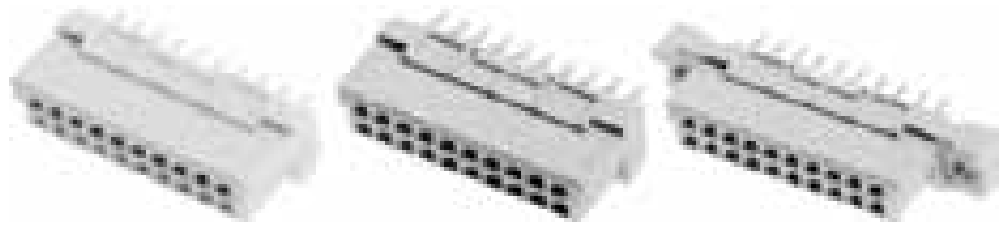

Female connectors

Identification	Number of contacts	Contact arrangement	Part No.	Performance levels according to IEC 60 603-2.		
				3	2	1
Female connector with solder pins 2.9 mm	20		Performance level 3 on request	09 24 220 6824	Performance level 1 on request	
with fixing flange, SMC				09 24 220 6841 ^{d)}		
without fixing flange, SMC				09 24 220 6414 ^{d)}		
Female connector with solder pins 4.5 mm	20		Performance level 3 on request	09 24 220 6825	Performance level 1 on request	
with fixing flange						
Female connector with press-in pins 4.5 mm	20		Performance level 3 on request	09 24 220 6850	Performance level 1 on request	
with fixing flange						
without fixing flange	20			09 24 220 6870		

DIN Signal up to 2 A

Dimensions

with fixing flange without fixing flange

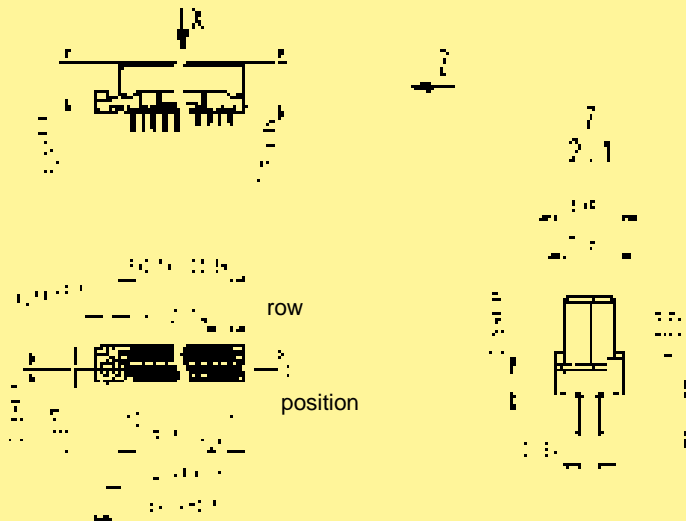

a	
2.9	solder pins
4.5	press-in pins

Board drillings

Mounting side

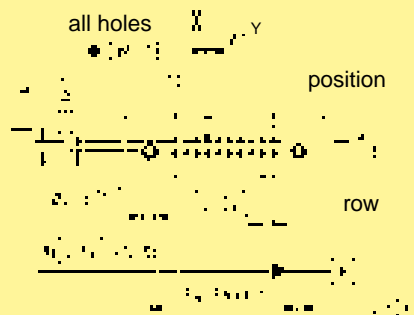

	Y
Solder	1 ± 0.1
Press-in	see recommendation page 00.25

Cross section of solder terminations



Cross area (A) of contacts row a, b, c: A = 0.20 - 0.23 mm²

Dimensions in mm

^{d)} CTI > 400



Number of contacts

96, 64, 32

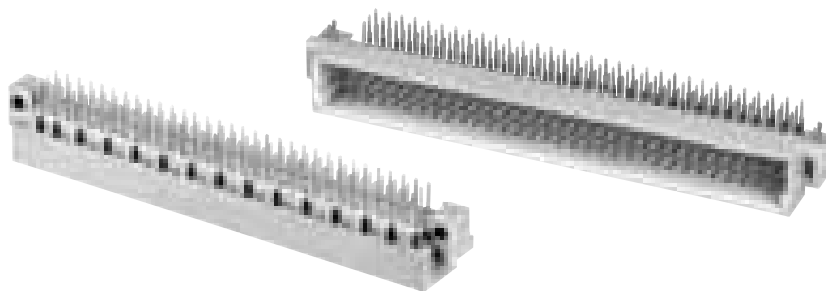

Male connectors

DIN Signal up to 2 A

Identification	Number of contacts	Contact arrangement	Part No.	Performance levels according to IEC 60603-2. Explanation chapter 00		
				3	2	1
Male connector with angled solder pins	96		09 03 196 7921	09 03 196 6921	09 03 196 2921	
			09 03 396 7921 ^{b)}	09 03 196 6921 222 ^{f)} 09 03 396 6921 ^{b)} 09 03 696 6921 ^{c)} 09 03 696 6921 222 ^{c)f)}	09 03 196 2921 222 ^{f)} 09 03 396 2921 ^{b)} 09 03 696 2921 ^{c)}	
		SMC			09 03 196 6919 ^{d)} 09 03 396 6919 ^{b)d)} 09 03 696 6919 ^{c)d)}	09 03 196 2919 ^{d)} 09 03 396 2919 ^{b)d)}
		64		09 03 164 7921	09 03 164 6921	09 03 164 2921
				09 03 364 7921 ^{b)}	09 03 164 6921 222 ^{f)} 09 03 364 6921 ^{b)} 09 03 664 6921 ^{c)}	09 03 164 2921 222 ^{f)} 09 03 364 2921 ^{b)} 09 03 664 2921 ^{c)}
	SMC				09 03 164 6919 ^{d)} 09 03 364 6919 ^{b)d)}	09 03 164 2919 ^{d)}
	32			09 03 132 7921	09 03 132 6921	09 03 132 2921
				09 03 332 7921 ^{b)}	09 03 332 6921 ^{b)}	09 03 332 2921 ^{b)}
	SMC	94 + 2 [▲]		09 03 196 7951	09 03 196 6951 09 03 396 6951 ^{b)}	09 03 196 2951
		94 + 2 [▲]			09 03 396 6918 ^{b)d)}	
62 + 2 [▲]			09 03 164 7951	09 03 164 6951	09 03 164 2951	
62 + 2 [▲]				09 03 164 6918 ^{d)}		
Male connector with straight solder pins	96		09 03 196 7922	09 03 196 6922	09 03 196 2922	
			SMC		09 03 196 6920 ^{d)}	
	64		09 03 164 7922	09 03 164 6922	09 03 164 2922	

[▲] Male connectors with 2 leading contacts [(0.8 mm) pos. a1 and a32]. Lagging pins on request.

^{b)} Connectors with snap-in clips see chapter 00

^{c)} Connectors with coding see chapter 00

^{d)} CTI > 400

^{f)} Railway classification NFF 16-101, Smoke index: F1, Flammability class: I2

Number of contacts

96, 64, 32

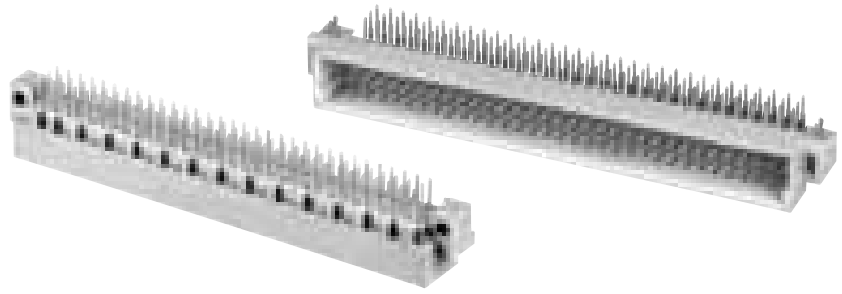

Male connectors

Identification

Drawing

Dimensions in mm

Dimensions

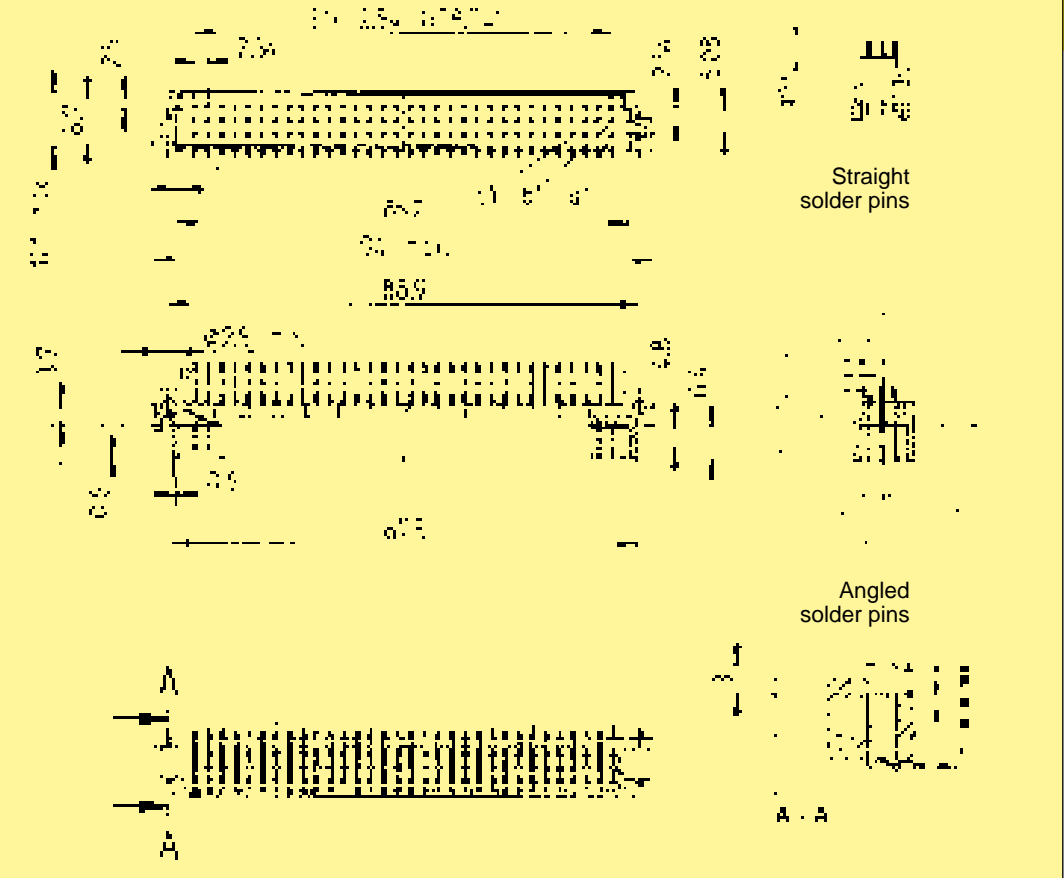

Board drillings
Mounting side

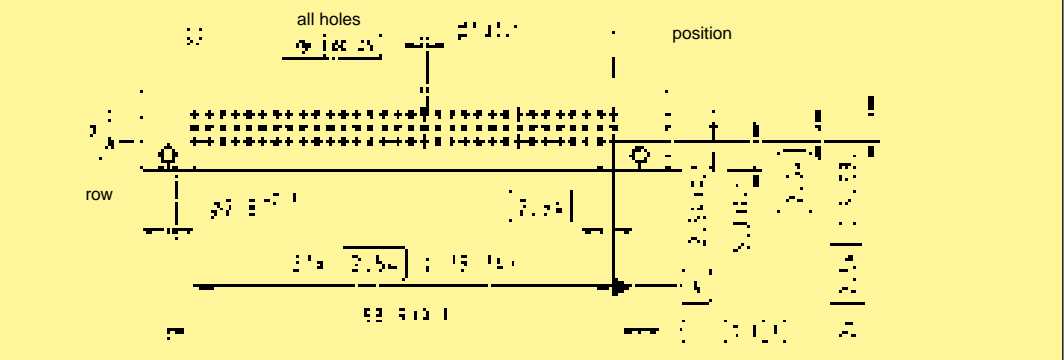

Cross section of solder terminations

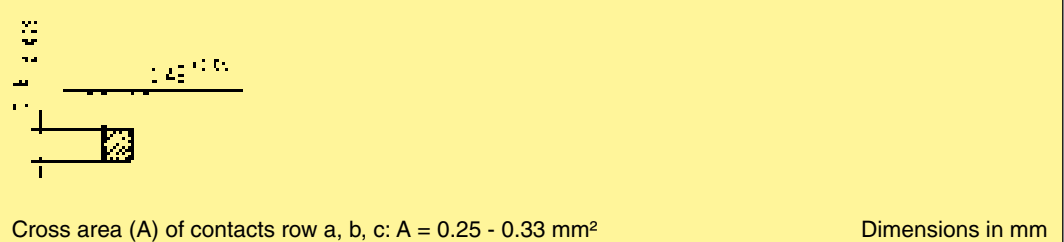

¹⁾ Recommendation for variants with clip: Drillings can be enlarged up to 3.1 mm \varnothing to reduce standard mounting force



Number of contacts

96, 64, 32

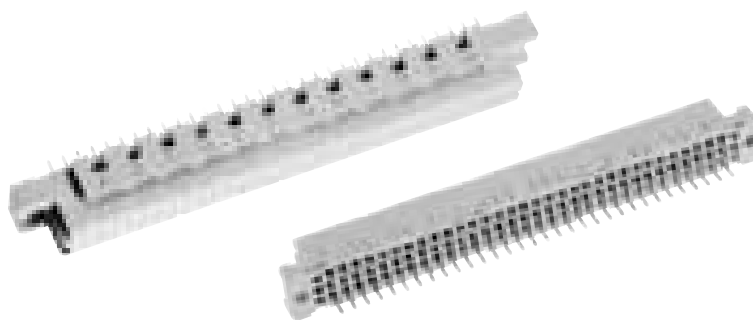

Female connectors

DIN Signal
up to 2 A

Identification	Number of contacts	Contact arrangement	Part No.	Performance levels according to IEC 60603-2. Explanation chapter 00		
				3	2	1
Female connector with solder pins 2.9 mm	96		09 03 296 7824	09 03 296 6824 09 03 296 6824 222 ^{f)} 09 03 496 6824 ^{b)} 09 03 796 6824 ^{c)}	09 03 296 2824 09 03 296 2824 222 ^{f)} 09 03 496 2824 ^{b)}	
				09 03 296 6841 ^{d)}		
	64		09 03 264 7824	09 03 264 6824 09 03 264 6824 222 ^{f)} 09 03 464 6824 ^{b)} 09 03 764 6824 ^{c)}	09 03 264 2824 09 03 264 2824 222 ^{f)} 09 03 464 2824 ^{b)}	
				09 03 264 6841 ^{d)}		
	32		09 03 232 7824	09 03 232 6824	09 03 232 2824	
	Female connector with kinked solder pins ¹⁾ 2.9 mm	96		09 03 296 7855	09 03 296 6855	09 03 296 2855
64			09 03 264 7855	09 03 264 6855		
32			09 03 232 7855	09 03 232 6855	09 03 232 2855	
Female connector with solder pins 4.5 mm	96		09 03 296 7825	09 03 296 6825 09 03 296 6825 222 ^{f)} 09 03 496 6825 ^{b)} 09 03 796 6825 ^{c)} 09 03 796 6825 222 ^{c)f)}	09 03 296 2825 09 03 296 2825 222 ^{f)}	
				09 03 296 6829 ^{d)}		
	64		09 03 264 7825 09 03 464 7825 ^{b)}	09 03 264 6825 09 03 464 6825 ^{b)} 09 03 764 6825 ^{c)}	09 03 264 2825	
				09 03 264 6829 ^{d)}		
	32		09 03 232 7825	09 03 232 6825	09 03 232 2825	
	Female connector with kinked solder pins ¹⁾ 4.5 mm	96		09 03 296 7845	09 03 296 6845	09 03 296 2845
64			09 03 264 7845	09 03 264 6845	09 03 264 2845	
32			09 03 232 7845	09 03 232 6845	09 03 232 2845	
Female connector with solder pins 13 mm	96			09 03 296 6421 09 03 796 6421 ^{c)}		
	64			09 03 264 6421 09 03 764 6421 ^{c)}		
	32			09 03 232 6421 09 03 732 6421 ^{c)}		

¹⁾ Kinked pins for fixing the connector onto the pcb see chapter 00
^{b)} Connectors with snap-in clips see chapter 00
^{c)} Connectors with coding see chapter 00

^{d)} CTI > 400
^{f)} Railway classification NFF 16-101, Smoke index: F1, Flammability class: I2

Number of contacts

96, 64, 32

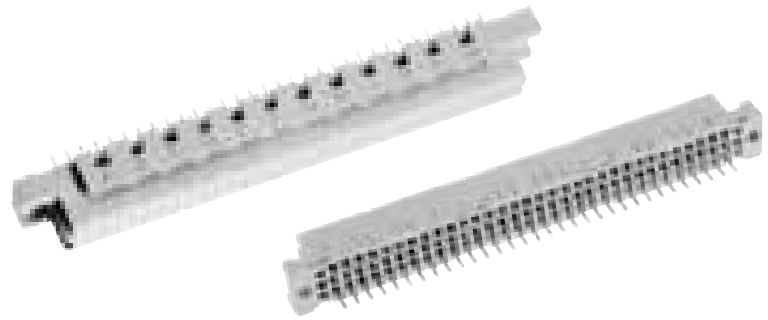

Female connectors

DIN Signal
up to 2 A

Identification

Drawing

Dimensions in mm

Dimensions

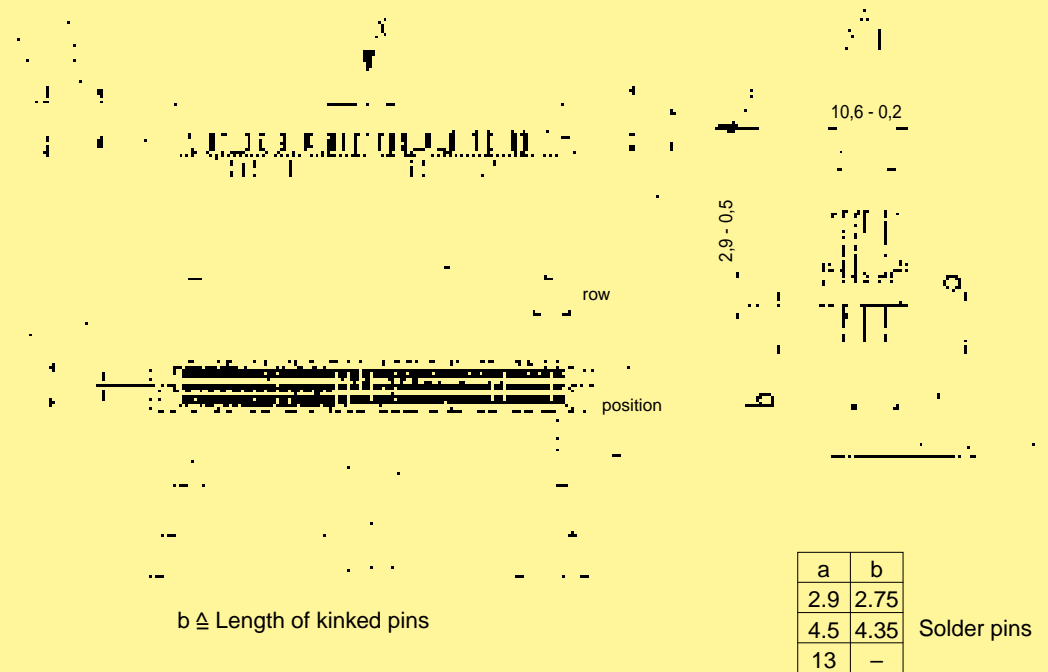

Board drillings

Mounting side



Cross section of solder terminations

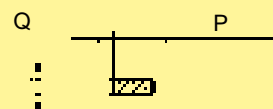

Cross area (A) of contacts

a	P	Q	A
2.9	0.75 _{-0.05}	0.30 _{±0.01}	0.20 - 0.23 mm ²
4.5	0.75 _{-0.05}	0.30 _{±0.01}	0.20 - 0.23 mm ²
13	0.60 _{-0.02}	0.60 _{-0.02}	0.33 - 0.38 mm ²

Dimensions in mm



Number of contacts

96, 64, 32

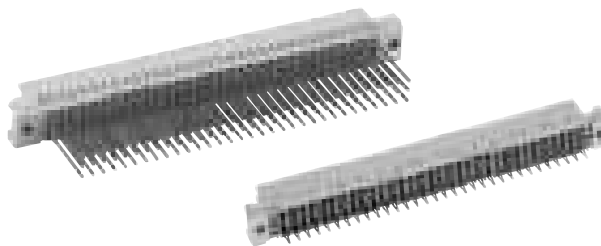

Female connectors

DIN Signal up to 2 A

Identification	Number of contacts	Contact arrangement	Part No.	Performance levels according to IEC 60 603-2. Explanation chapter 00		
				3	2	1
Female connector Type C with press-in terminations	4.5 mm	96	09 03 296 7850	09 03 296 6850 09 03 296 6850 222 ^{f)} 09 03 796 6850 ^{e)} 09 03 796 6850 222 ^{e)f)}	09 03 296 2850 09 03 296 2850 222 ^{f)}	
		64	09 03 264 7850	09 03 264 6850 09 03 264 6850 222 ^{f)}	09 03 264 2850	
		32		09 03 232 6850	09 03 232 2850	
	13.2 mm	96		09 03 296 6851 09 03 296 6861*		
		64		09 03 264 6851 09 03 264 6861*		
	17 mm	96		09 03 296 6852 09 03 296 6862*		

Dimensions

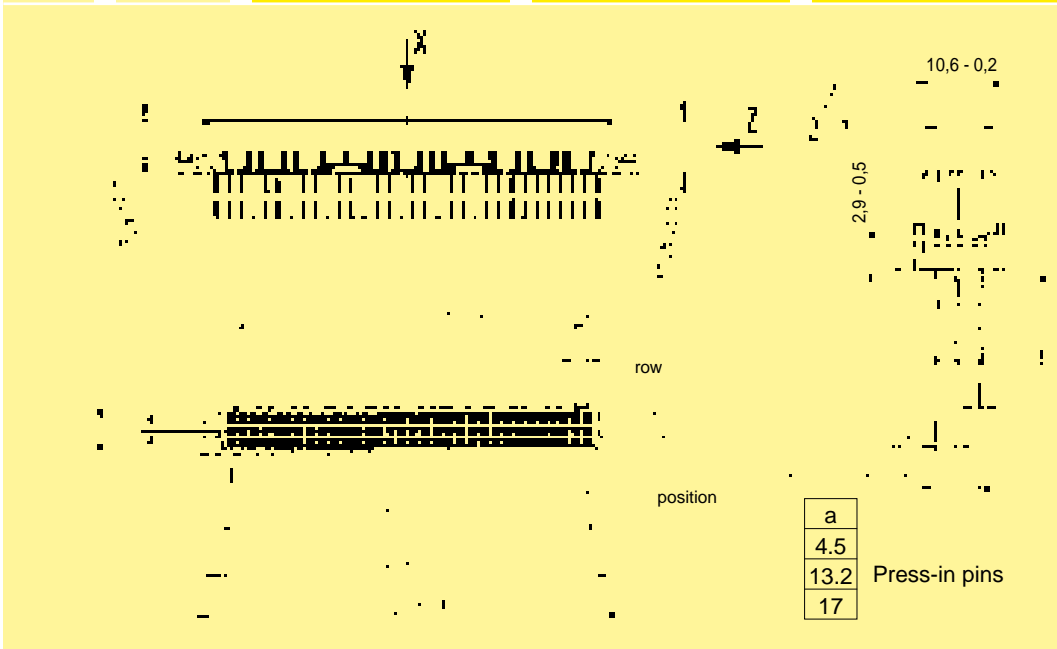

Board drillings

Mounting side

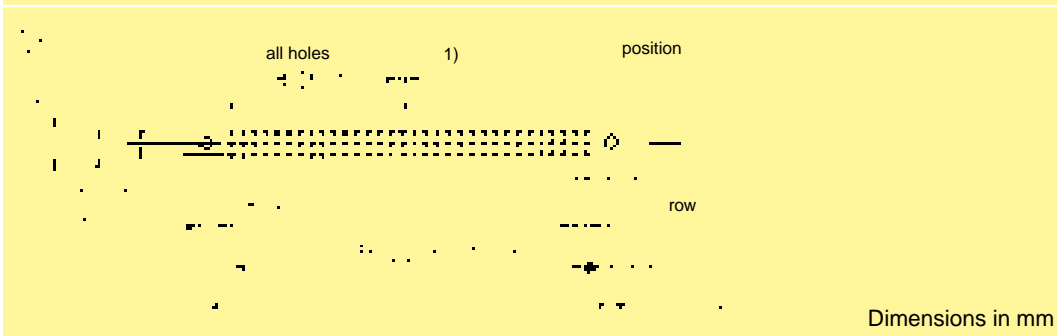

Dimensions in mm

* Wrap posts for interfacing selectively gold plated (performance level 3)

Other contact arrangements on request

¹⁾ refer to recommended configuration of pcb holes, see page 00.25

^{e)} Connectors with coding see chapter 00

^{f)} Railway classification NFF 16-101, Smoke index: F1, Flammability class: I2

Number of contacts

96, 64

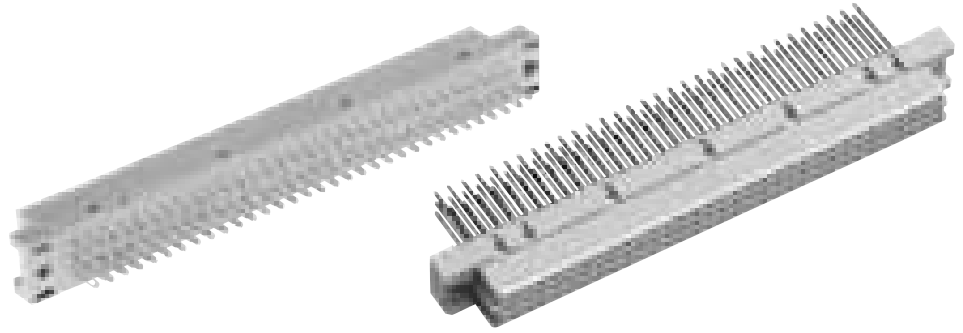

Female connectors

Identification	Number of contacts	Contact arrangement	Part No.	Performance levels according to IEC 60603-2. Explanation chapter 00 2
Female connector with wrap posts ²⁾ 13 mm	96			09 03 296 6821 09 03 796 6821 ^{c)} 09 03 296 6878 ¹⁾
	64			09 03 264 6821 09 03 764 6821 ^{c)} 09 03 264 6878 ¹⁾
Female connector with solder lugs a + c 5.2 mm b 7.7 mm	96			09 03 296 6823 09 03 796 6823 ^{c)}
	64			09 03 264 6823 09 03 764 6823 ^{c)}

Dimensions

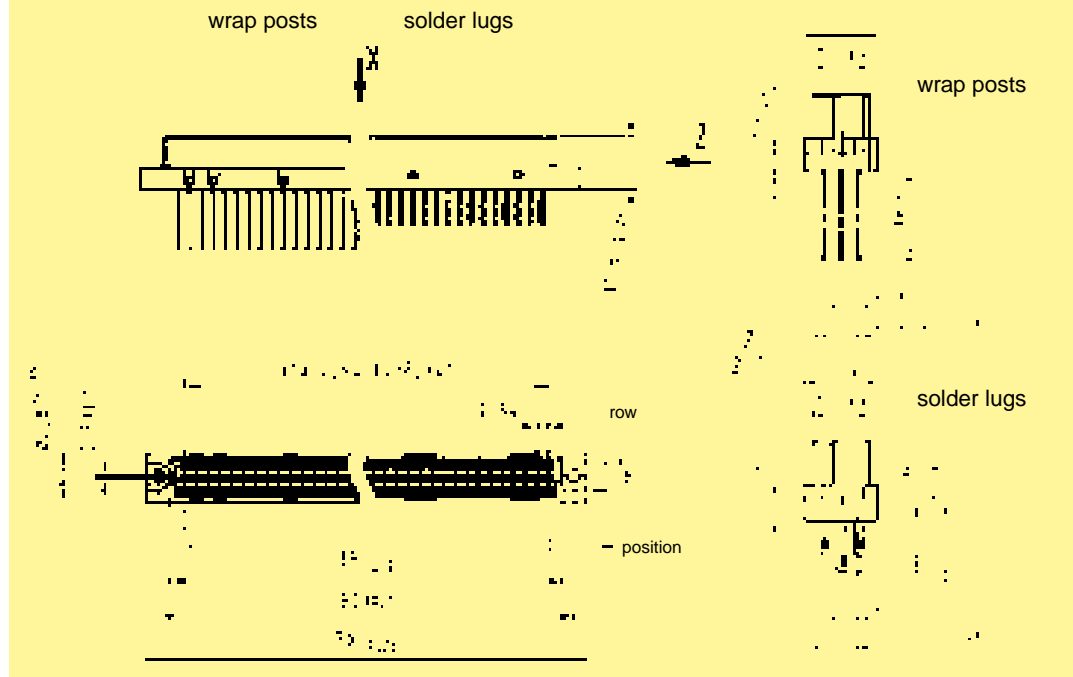

Panel cut out

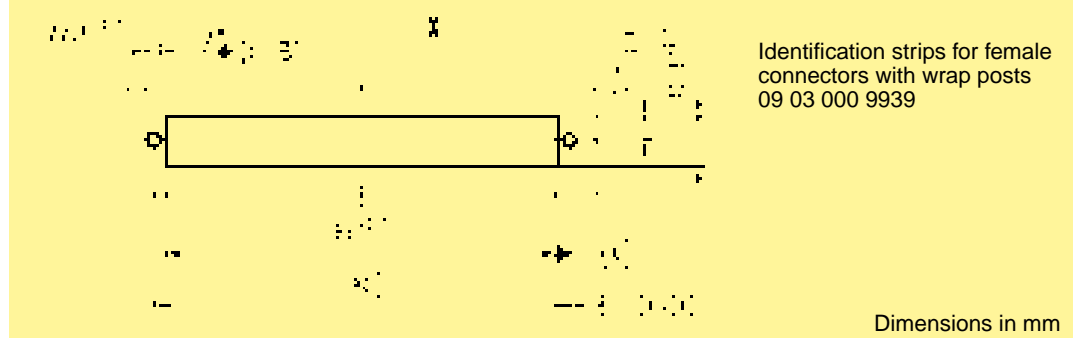

Dimensions in mm

DIN Signal up to 2 A

¹⁾ Wrap posts for interfacing, selectively gold-plated (performance level 3)
²⁾ To be used only for wire wrap termination. Solder versions see page 01.22
^{c)} Connectors with coding see chapter 00

Number of contacts

64

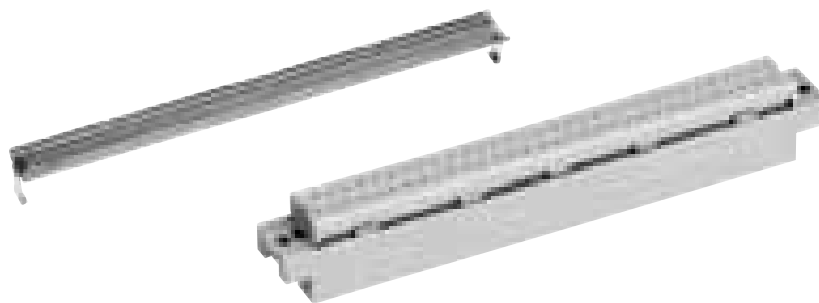

Female connectors

DIN Signal up to 2 A

Identification	Number of contacts	Part No.	Drawing	Dimensions in mm
Female connector for insulation displacement	64	Performance level 2 ¹⁾ 09 03 264 6828 09 03 764 6828 ^{c)} Performance level 3 ¹⁾ 09 03 264 7828	<p>Cable 1 to contact 1 c Contact arrangement View from termination side</p>	
Strain relief (metal)		09 03 000 9940		
Panel cut out			<p>Mateable with 3 row male connector type C, no female contacts in the middle row</p>	
Flat cable AWG 28/7 grey 30.48 m grey 100.00 m colour coded 30.48 m twisted pair ²⁾ 30.48 m	64	09 18 064 7001 09 18 064 7004 09 18 064 7005 09 18 064 7006	<p>Wire (tinned) Cu Gauge AWG 28/7 0.089 mm² Insulation material as per UL style PVC</p>	²⁾ Termination area spacing = 508 mm Important: always store reels vertically
Round flat cable ³⁾ with screening 30.48 m 100.00 m without screening 30.48 m 100.00 m	64	09 18 064 7007 09 18 064 7010 09 18 064 7008 09 18 064 7011	<p>Edge mark on first conductor AWG 28/7 grey</p>	³⁾ Termination area spacing = 100 mm
Bench press		09 99 000 0114		
Base plate		09 99 000 0150		
Cable cutter		09 99 000 0116		
Spare parts				
Blade		09 99 000 0179		
Cutting plate		09 99 000 0180		

Number of contacts

max. 96, 48



Female connectors

DIN Signal up to 2 A

Identification	Number of contacts	Part No.	Drawing	Dimensions in mm																		
Female connector for crimp contacts Order contacts separately																						
Type C	96	09 03 096 3214 ^{d)} 09 03 596 3214 ^{e)}		<table border="1"> <thead> <tr> <th></th> <th>a</th> <th>b</th> <th>c</th> <th>d</th> <th>e</th> </tr> </thead> <tbody> <tr> <td>C</td> <td>84.93 ±0.07</td> <td>83.95 ±0.05</td> <td>31 x 2.54 (= 78.74)</td> <td>90.00 ±0.1</td> <td>94.80 ±0.1</td> </tr> <tr> <td>2C</td> <td>44.35 ±0.05</td> <td>43.85 ±0.05</td> <td>15 x 2.54 (= 38.1)</td> <td>49.68 ±0.1</td> <td>54.80 ±0.1</td> </tr> </tbody> </table>		a	b	c	d	e	C	84.93 ±0.07	83.95 ±0.05	31 x 2.54 (= 78.74)	90.00 ±0.1	94.80 ±0.1	2C	44.35 ±0.05	43.85 ±0.05	15 x 2.54 (= 38.1)	49.68 ±0.1	54.80 ±0.1
	a	b			c	d	e															
C	84.93 ±0.07	83.95 ±0.05			31 x 2.54 (= 78.74)	90.00 ±0.1	94.80 ±0.1															
2C	44.35 ±0.05	43.85 ±0.05			15 x 2.54 (= 38.1)	49.68 ±0.1	54.80 ±0.1															
Type C	96	09 03 096 3217 ^{f)}																				
Position marking turned for mating type R male																						
Type 2C	48	09 23 048 3214 ^{d)}																				
Type 2C	48	09 23 048 3217 ^{f)}																				
Position marking turned for mating type 2R male																						

Shell housing see chapter 20

Identification	Part No.	Performance levels according to IEC 60603-2. Explanation chapter 00
	2	1
Female crimp contacts BC		
Bandoliered contacts (approx. 5,000 pieces)	09 02 000 6484	09 02 000 6474
Bandoliered contacts (approx. 500 pieces)	09 02 000 8434	09 02 000 8444
Individual contacts ¹⁾	09 02 000 8484	09 02 000 8474
	Wire gauge mm ² AWG Insulation ø mm 0.09 - 0.5 28 - 20 0.7 - 1.5	
	3.5 + 0.5 mm of insulation is stripped from the wires to be crimped For the fabrication in line with the specification please use exclusively crimp tools approved by HARTING (see DIN EN 60352-2) Insertion, removal and crimping tools see chapter 30	

^{d)} Connectors with coding see chapter 00

¹⁾ Packaging unit 1,000 pieces

^{f)} Railway classification NFF 16-101, Smoke index: F1, Flammability class: I2



Number of contacts

48, 32, 16

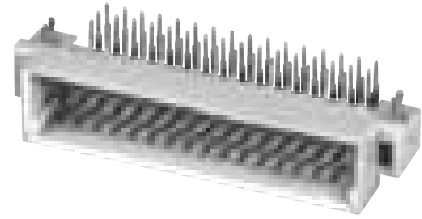
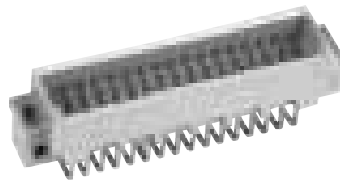

Male connectors

DIN Signal
up to 2 A

Identification	Number of contacts	Contact arrangement	Part No.	Performance levels according to IEC 60603-2. Explanation chapter 00		
				3	2	1
Male connector with angled solder pins	48		09 23 148 7921	09 23 148 6921	09 23 148 2921	
			09 23 348 7921 ^{b)}	09 23 148 6921 222 ^{f)}	09 23 348 6921 ^{b)}	
	SMC	48		09 23 148 7919	09 23 148 6919 ^{d)}	09 23 348 6919 ^{b)d)}
	SMC	32		09 23 132 7921	09 23 132 6921	09 23 132 2921
				09 23 332 7921 ^{b)}	09 23 332 6921 ^{b)}	
	SMC	32			09 23 132 6919 ^{d)}	09 23 332 6919 ^{b)d)}
	16			09 23 116 6931	09 23 116 2931	
				09 23 316 6931 ^{b)}		
	46 + 2 [▲]		09 23 148 7951	09 23 148 6951	09 23 348 6951 ^{b)}	
Male connector with straight solder pins	48		09 23 148 7922	09 23 148 6922	09 23 148 2922	
	SMC	48			09 23 148 6920 ^{d)}	
	SMC	32		09 23 132 7922	09 23 132 6922	09 23 132 2922
	32			09 23 132 6920 ^{d)}		

▲ Male connectors with 2 leading contacts [(0.8 mm) pos. a1 and a16]. Lagging pins on request.

Other contact arrangements on request

^{b)} Connectors with snap-in clips see chapter 00

^{d)} CTI > 400

^{f)} Railway classification NFF 16-101, Smoke index: F1, Flammability class: I2

Number of contacts

48, 32, 16

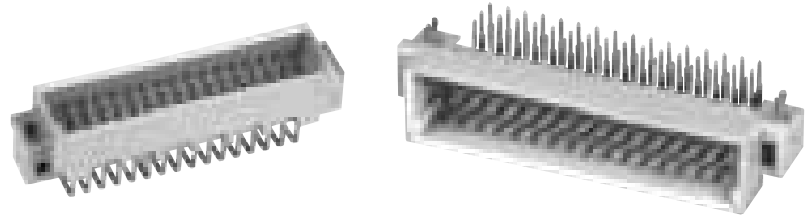

Male connectors

Identification

Drawing

Dimensions in mm

Dimensions

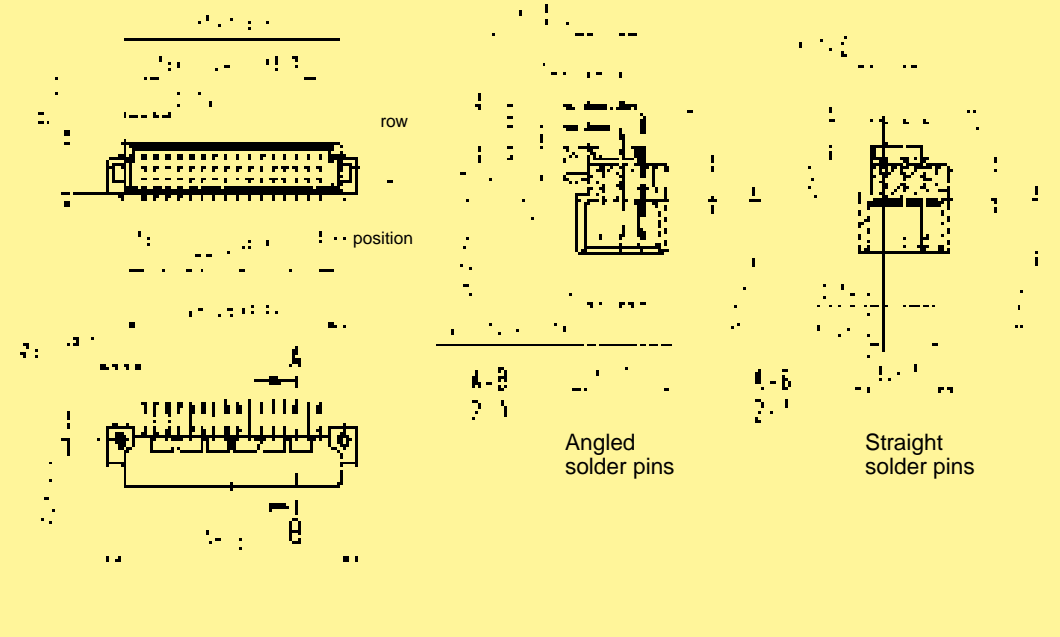

Board drillings

Mounting side

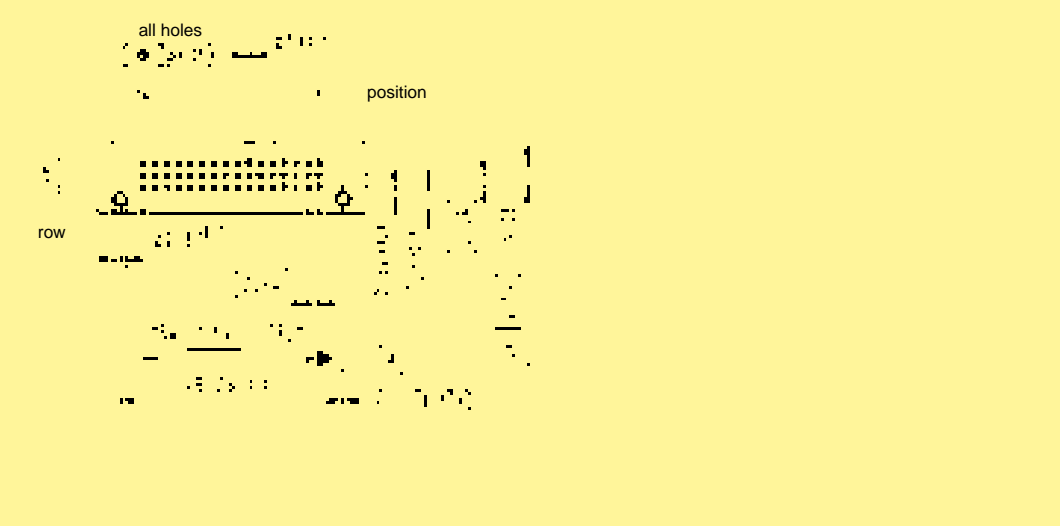

Cross section of solder terminations

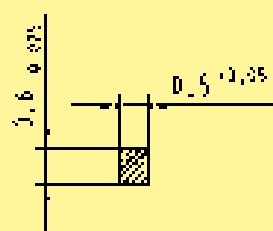

Cross area (A) of contacts row a, b, c: $A = 0.29 - 0.33 \text{ mm}^2$

DIN Signal
up to 2 A

¹⁾ Recommendation for variants with clip: Drillings can be enlarged up to 3.1 mm ϕ to reduce standard mounting force



Number of contacts

48, 32

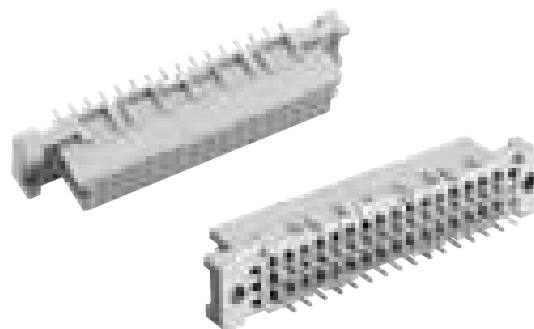

Female connectors

DIN Signal
up to 2 A

Identification	Number of contacts	Contact arrangement	Part No.	Performance levels according to IEC 60603-2. Explanation chapter 00		
				3	2	1
Female connector with solder pins 2.9 mm	48			09 23 248 6824	09 23 248 2824	
				09 23 248 6824 222 ^{f)} 09 23 448 6824 ^{b)}		
	SMC	48			09 23 248 6841 ^{d)}	
		32			09 23 232 6824 09 23 432 6824 ^{b)}	
SMC	32			09 23 232 6841 ^{d)}		
Female connector with solder pins 4.5 mm	48			09 23 248 6825	09 23 248 2825	
				09 23 248 6825 222 ^{f)} 09 23 448 6825 ^{b)}		
	SMC	48			09 23 248 6829 ^{d)}	
		32		09 23 232 7825	09 23 232 6825	
SMC	32			09 23 232 6829 ^{d)}		
Female connector with solder pins 13 mm	48			09 23 248 6421		
Female connector with press-in pins 3.7 mm	48			09 23 248 6866		
Female connector with press-in pins 4.5 mm	48			09 23 248 6850	09 23 248 2850	
	32			09 23 232 6850		
Female connector with wrap posts ¹⁾ 13 mm	48			09 23 248 6821		
Female connector with solder lugs 5.2 mm	32			09 23 232 6823		
Female connector with crimp contacts	48		Part numbers and variants see page 01.27			

01
30

Other contact arrangements on request

¹⁾ To be used only for wire wrap termination

^{b)} Connectors with snap-in clips see chapter 00

^{d)} CTI > 400

^{f)} Railway classification NFF 16-101, Smoke index: F1, Flammability class: I2



Number of contacts

48, 32

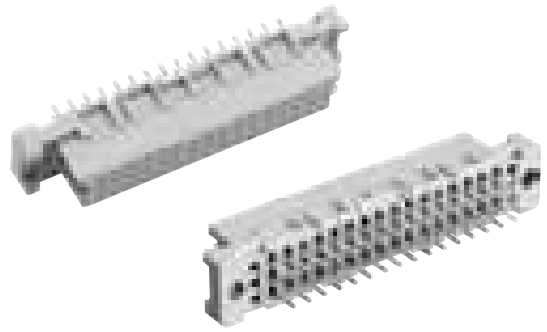

Female connectors

Identification Number of contacts Contact arrangement Part No. Performance levels according to IEC 60603-2. Explanation chapter 00

Dimensions

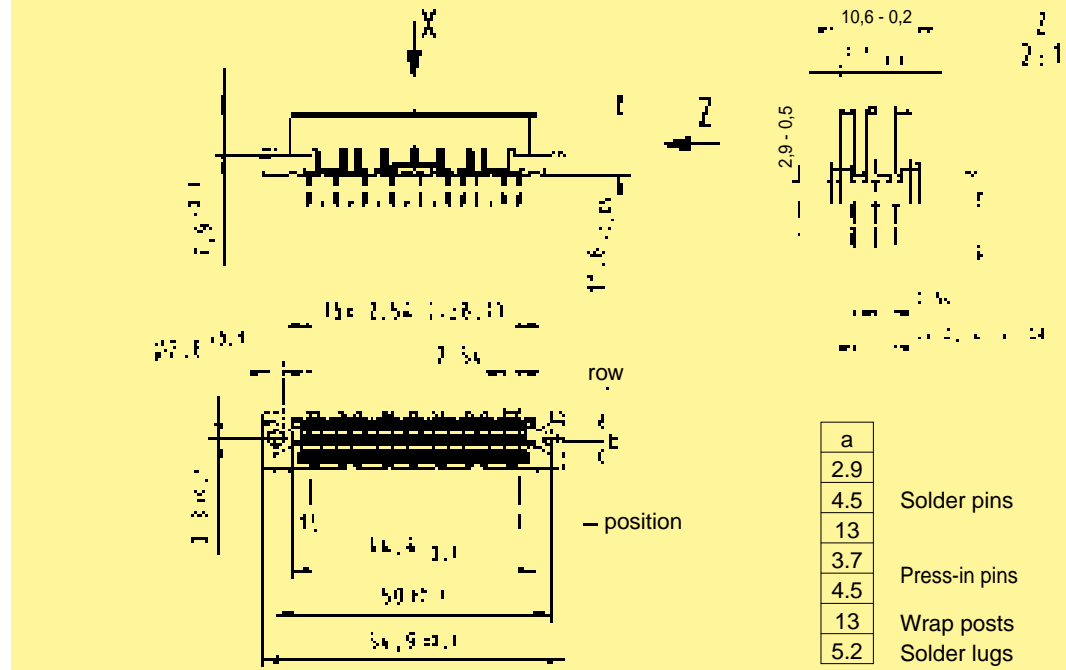

Board drillings
Mounting side

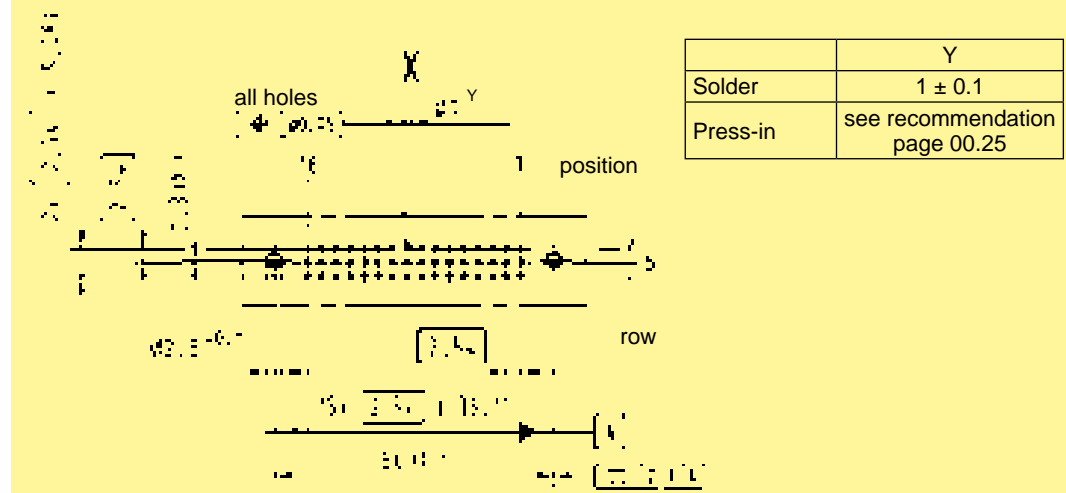

Cross section of solder terminations

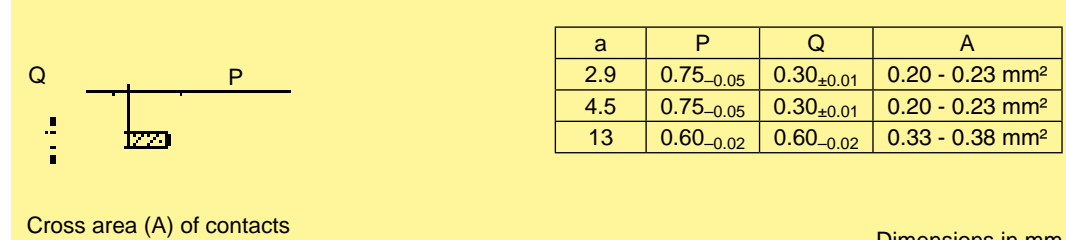

Cross area (A) of contacts

Dimensions in mm

DIN Signal up to 2 A

DIN 41 612 · complementary type 3C



Number of contacts

30, 20

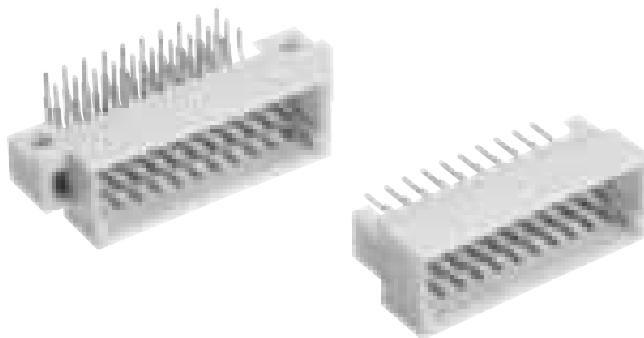

Male connectors

DIN Signal
up to 2 A

Identification	Number of contacts	Contact arrangement	Part No.	Performance levels according to IEC 60 603-2.	
			3	2	1
Male connector with angled solder pins					
with fixing flange	30		Performance level 3 on request	09 25 130 6921	Performance level 1 on request
	20			09 25 120 6921	
with fixing flange, SMC	30			09 25 130 6919 ^{d)}	
without fixing flange	30			09 25 130 6571	
without fixing flange, SMC	30			09 25 130 6579 ^{d)}	
Male connector with straight solder pins					
with fixing flange	30		Performance level 3 on request	09 25 130 6922	Performance level 1 on request
	20			09 25 120 6922	
without fixing flange	30			09 25 130 6572	
without fixing flange, SMC	30			09 25 130 6590 ^{d)}	

Other contact arrangements on request
^{d)} CTI > 400

Number of contacts

30, 20

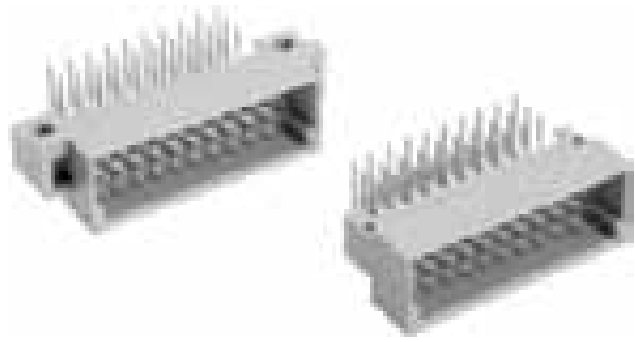

Male connectors

Identification

Drawing

Dimensions in mm

Dimensions

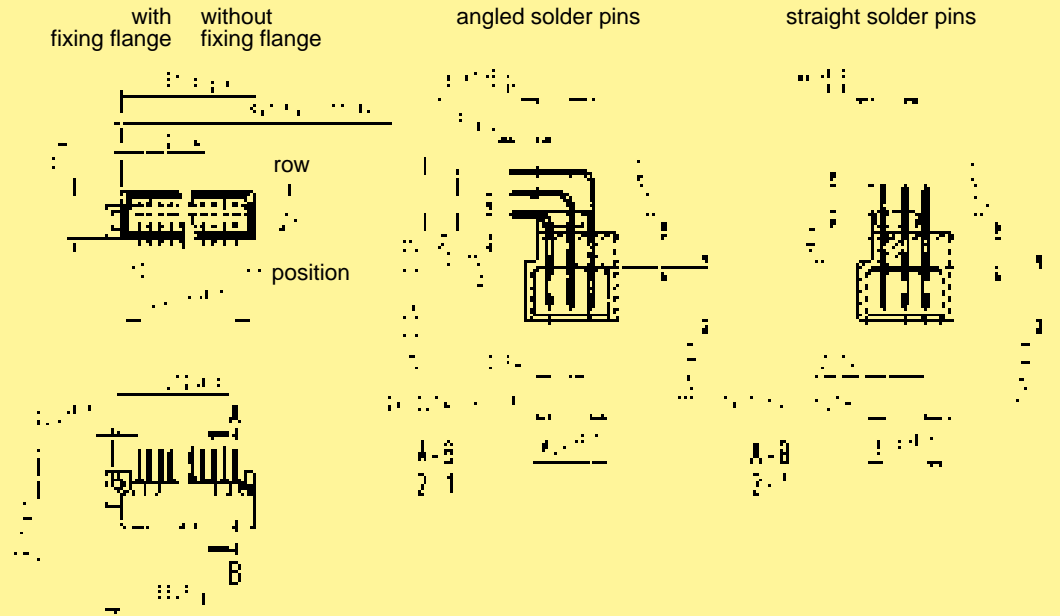

Board drillings
Mounting side



Cross section of solder terminations

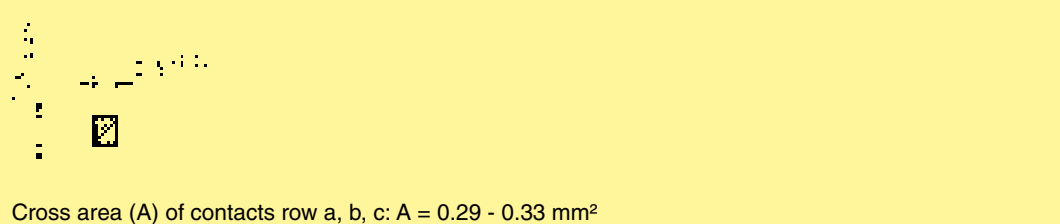

DIN Signal
up to 2 A

DIN 41 612 · complementary type 3C



Number of contacts

30, 20

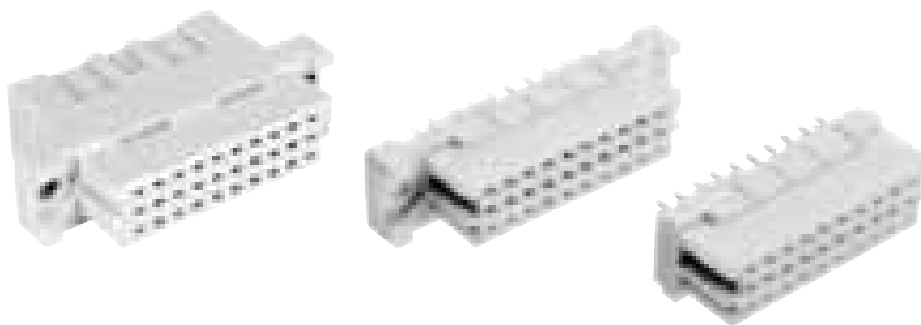

Female connectors

DIN Signal up to 2 A

Identification	Number of contacts	Contact arrangement	Part No.	Performance levels according to IEC 60 603-2.					
			3	2	1				
Female connector with solder pins 2.9 mm	with fixing flange		Performance level 3 on request	Performance level 2	Performance level 1	09 25 230 6824			
		20					09 25 220 6824		
	with fixing flange, SMC	30					09 25 230 6841 ^{d)}		
	without fixing flange, SMC	30					09 25 230 6414 ^{d)}		
Female connector with solder pins 4.5 mm	with fixing flange					Performance level 3 on request	Performance level 2	Performance level 1	09 25 230 6825
		20							
Female connector with press-in pins 4.5 mm	with fixing flange		Performance level 3 on request	Performance level 2	Performance level 1				09 25 230 6850
	without fixing flange	30							

Identification	Number of contacts	Part No.	Drawing	Dimensions in mm
Female connector for crimp contacts Order contacts separately see page 01.27				
Type 3C	30	09 25 030 3214 ^{f)}		

^{d)} CTI > 400

^{f)} Railway classification NFF 16-101, Smoke index: F1, Flammability class: I2

Number of contacts

30, 20

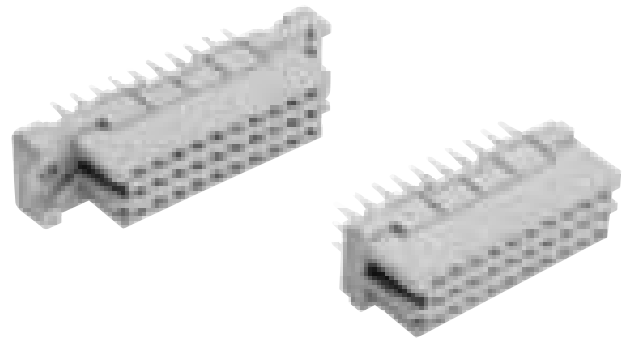

Female connectors

Identification

Drawing

Dimensions in mm

Dimensions

with fixing flange without fixing flange

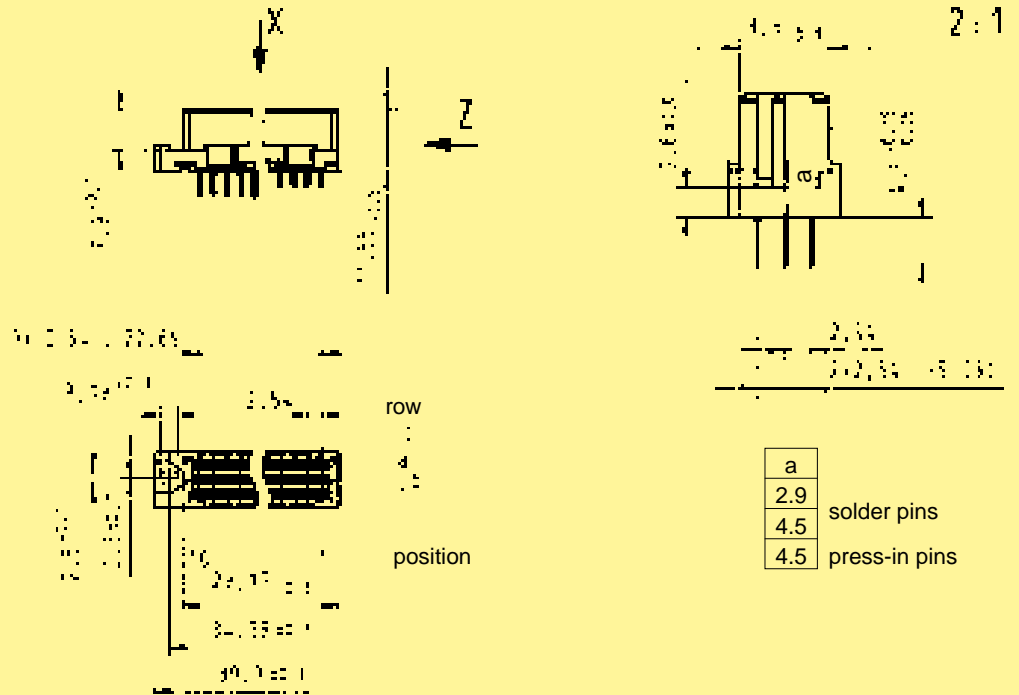

Board drillings

Mounting side

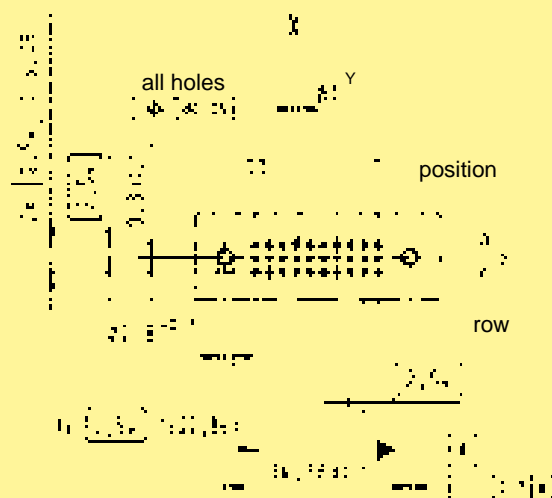

	Y
Solder	1 ± 0.1
Press-in	see recommendation page 00.25

Cross section of solder terminations

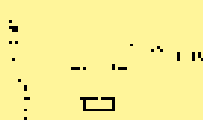

Cross area (A) of contacts row a, b, c: A = 0.20 - 0.23 mm²



DIN Signal up to 2 A

Application matrix				Board to Backplane			Mezzanine		
				1.	2.	3.	4.	5.	
<ul style="list-style-type: none"> • Coax Contacts • High Voltage Contacts • FOC- Contacts 				M male & M female	M male & M flat female	MH 21+ 5 male & MH 21+ 5 female	M invers male & M female	M invers male & M flat female	
Connector	Part number								
Male connector type M angled	09 03 1XX X901			○	○				
Female connector type M straight	09 03 2XX 6804			◇	◇		◇		
Female connector type M straight	09 03 2XX 6805			◇	◇		◇		
Female connector type M straight	09 03 2XX 6850			◇	◇		◇		
Female connector type M flat	09 03 2XX 6864				◇			◇	
Female connector type M flat	09 03 2XX 6865				◇			◇	
Female connector type M flat	09 03 2XX 6830				◇			◇	
Male connector type MH 21+5	09 06 X21 6883					○			
Female connector type MH 21+5	09 06 121 6981					◇			
Male connector type M invers	09 73 1XX 6902						○	○	
Male connector type M invers	09 73 1XX 6903						○	○	
Male connector type M invers	09 73 1XX 6904						○	○	
Male connector type M invers	09 73 1XX 6907						○	○	
Male connector type M invers	09 73 1XX 6974						○	○	
Male connector type M invers	09 73 1XX 6985						○	○	
Impedance				Termination			Part number		
50 Ω	cable	solder/crimp	09 03 000 6160	◆		◆	◆		
50 Ω	cable	solder/crimp	09 03 000 6161	◆		◆	◆		
50 Ω	pcb	solder	09 03 000 6165	◆		◆	◆		
50 Ω	cable	solder	09 03 000 6167	◆		◆	◆		
75 Ω	cable	solder/crimp	09 03 000 6181	◆	◆	◆	◆		
50 Ω	pcb	solder	09 03 000 6182	◆	◆	◆	◆	◆	
50 Ω	cable	solder/crimp	09 03 000 6260	●	●	●	●	●	
50 Ω	cable	solder/crimp	09 03 000 6261	●	●	●	●	●	
50 Ω	pcb	solder	09 03 000 6262	●	●	●	●	●	
50 Ω	pcb	solder	09 03 000 6263	●	●	●	●	●	
75 Ω	pcb	solder	09 03 000 6269	●	●	●	●	●	
50 Ω	cable	solder/crimp	09 03 000 6274	●	●	●	●	●	
75 Ω	cable	solder/crimp	09 03 000 6281	●	●	●	●	●	
High voltage 1.5 KV				09 03 000 6140			●	●	
				09 03 000 6240			◆	◆	
FOC ceramic ferrule*				20 10 125 4212			●	●	
				20 10 125 4222			◆	◆	
FOC for SI-fibre (HCS)*				20 10 230 4211			●	●	
				20 10 230 4221			◆	◆	
FOC for 1 mm (POF)*				20 10 001 4211			●	●	
				20 10 001 4221			◆	◆	

● = can be used in ○ male connector

○ = male connector for ● contacts

* details see catalogue Industrial Connectors Han®

◆ = can be used in ◇ female connector

◇ = female connector for ◆ contacts



Application matrix • High Power Contacts					Board to Backplane			Mezzanine	
					1.	2.	3.	4.	5.
					M male & M female	M male & M flat female	MH 21+ 5 male & MH 21+ 5 female	M invers male & M female	M invers male & M flat female
Connector	Part number								
Male connector type M angled	09 03 1XX X901				○	○			
Female connector type M straight	09 03 2XX 6804				◇			◇	
Female connector type M straight	09 03 2XX 6805				◇			◇	
Female connector type M straight	09 03 2XX 6850				◇			◇	
Female connector type M flat	09 03 2XX 6864					◇			◇
Female connector type M flat	09 03 2XX 6865					◇			◇
Female connector type M flat	09 03 2XX 6830					◇			◇
Male connector type MH 21+5	09 06 X21 6883						○		
Female connector type MH 21+5	09 06 121 6981						◇		
Male connector type M invers	09 73 1XX 6902							○	○
Male connector type M invers	09 73 1XX 6903							○	○
Male connector type M invers	09 73 1XX 6904							○	○
Male connector type M invers	09 73 1XX 6907							○	○
Male connector type M invers	09 73 1XX 6974							○	○
Male connector type M invers	09 73 1XX 6985							○	○
Currency	Termination	Preleading	Part number						
10 A	cable	solder	–	09 03 000 6101	●	●	●	●	●
20 A	cable	solder	–	09 03 000 6102	●	●	●	●	●
40 A	cable	solder	–	09 03 000 6103	●	●	●	●	●
40 A	pcb	solder	–	09 03 000 6104	●	●	●	●	●
40 A	pcb	solder	–	09 03 000 6110	●	●	●	●	●
10 A	cable	solder	0.8	09 03 000 6111	●	●	●	●	●
10 A	cable	crimp	–	09 03 000 6113	●	●	●	●	●
20 A	cable	crimp	–	09 03 000 6114	●	●	●	●	●
40 A	cable	crimp	–	09 03 000 6115	●	●	●	●	●
20 A	cable	solder	0.8	09 03 000 6122	●	●	●	●	●
40 A	pcb	solder	–	09 03 000 6127*	●	●	●	●	●
40 A	pcb	solder	1.8	09 03 000 6128*	●	●	●	●	●
40 A	cable	solder	0.8	09 03 000 6133	●	●	●	●	●
40 A	pcb	solder	0.6	09 03 000 6134	●	●	●	●	●
10 A	cable	solder	–	09 03 000 6201	◆			◆	
20 A	cable	solder	–	09 03 000 6202	◆			◆	
40 A	cable	solder	–	09 03 000 6203	◆			◆	
10 A	cable	crimp	–	09 03 000 6213	◆			◆	
20 A	cable	crimp	–	09 03 000 6214	◆			◆	
40 A	cable	crimp	–	09 03 000 6215	◆			◆	
20 A	cable	crimp	–	09 03 000 6220*	◆			◆	
40 A	pcb	solder	–	09 03 000 6225		◆			◆
40 A	busbar	screw	–	09 03 000 6245		◆	◆	◆	◆
40 A	pcb	press-in	–	09 03 000 6250		◆			◆

DIN Signal up to 2 A

● = can be used in ○ male connector
 ○ = male connector for ● contacts
 * see also chapter 04

◆ = can be used in ◇ female connector
 ◇ = female connector for ◆ contacts

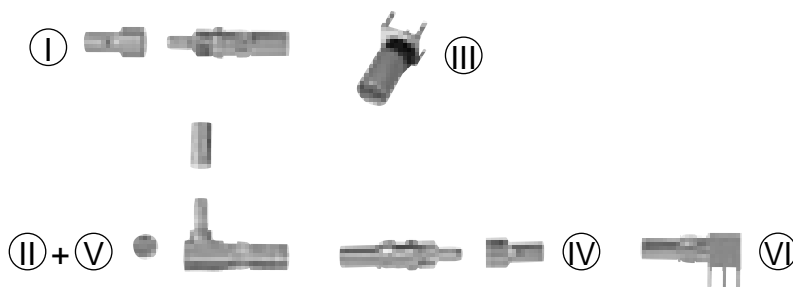

Coaxial contacts

DIN Signal up to 2 A

Identification Part No. Performance level 1 Drawing Dimensions in mm

Male coaxial contacts for female connectors

acc. to DIN 41 626

Ⓘ for straight solder and/or crimp termination

09 03 000 6160
09 03 000 6181¹⁾

Ⓜ for angled solder and/or crimp termination

09 03 000 6161

ⓂⓂ for straight pcb termination for type M-flat

09 03 000 6182

for type M

09 03 000 6165

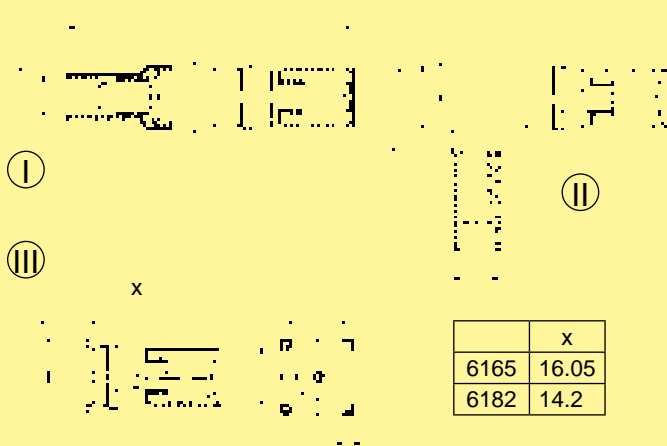

Female coaxial contacts for male connectors

Ⓧ for straight solder and/or crimp termination

09 03 000 6260
09 03 000 6281¹⁾
09 03 000 6274²⁾

Ⓧ for angled solder and/or crimp termination

09 03 000 6261

ⓍⓍ angled for pcb termination

09 03 000 6262
09 03 000 6269¹⁾
09 03 000 6263²⁾

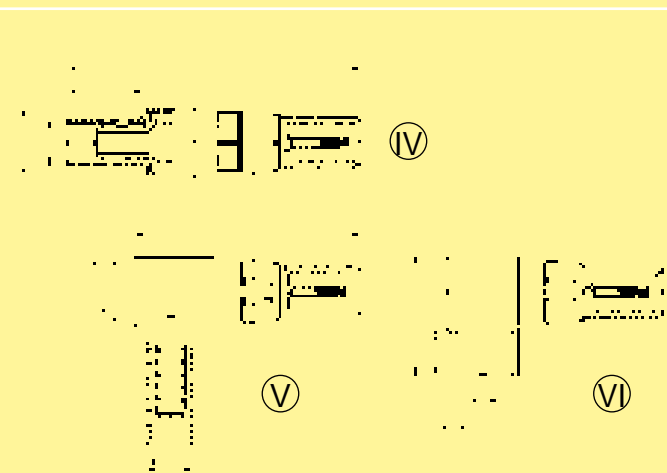

Assembly instruction for contacts

Ⓘ and Ⓧ



for contacts

Ⓜ and Ⓧ

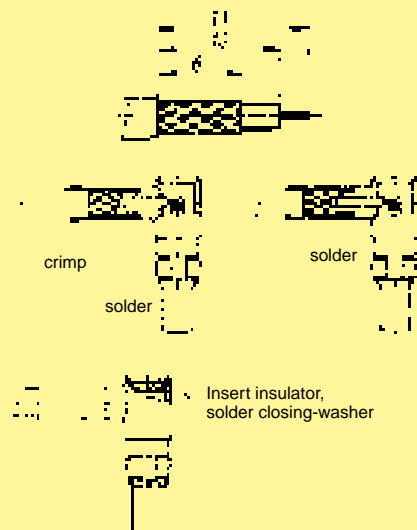

¹⁾ Coaxial contact 75 Ω
²⁾ With knurled area for permanent fixing, not removable
Fibre optic contacts on request

DIN 41 612 · Special contacts type M



High voltage contacts

Identification	Part No. Performance level 1	Drawing	Dimensions in mm
High voltage male contact for male connectors²⁾ I for straight solder termination 2.8 kV acc. to DIN 41 626 09 03 000 6140			
High voltage female contact for female connectors²⁾ II for straight solder termination 2.8 kV 09 03 000 6240			
Crimping tool for coaxial contacts 09 99 000 0194			
Crimping tool for high current contacts 09 99 000 0196			
Removal tool incl. removal jacket for contact replacement in male and female connectors III 09 99 000 0174			
Replacement removal jacket 09 99 000 0243			
Removal tool for contact replacement in male connectors IV 09 99 000 0328			

Electrical characteristics of coaxial contacts and wires

	50 Ω	75 Ω
Impedance	50 Ω	75 Ω
Max. working frequency	0 up to 10 GHz	0 up to 1.5 GHz
Return loss	≥ 20 dB up to 6 GHz	≥ 20 dB
RF-leakage	≥ 80 dB up to 0.5 GHz ≥ 68 dB up to 1.5 GHz	
Test voltage	750 V _{rms}	
Working voltage	250 V _{max.}	
Insulation resistance	≥ 1 GΩ	≥ 200 MΩ
Contacts resistance – Center contact	≤ 10 mΩ	
– Outer contact	≤ 3 mΩ	
Contact current max.	1.5 A	
Admissible power (depends on: frequency, application, return loss, environmental characteristics)	Data on request	

Cable group 2 flexible wires	Impedance	Shell ø	Screening ø	Dielectric ø	Internal wire ø	Hexagonal crimp Spanner width
RG 174 A/U	50 Ω	2.5	2.0	1.5	0.48	3.25
RG 188 A/U	50 Ω	2.6	2.0	1.5	0.54	3.25
RG 316 U	50 Ω	2.5	2.0	1.5	0.54	3.25
RG 179 B/U	75 Ω	2.54	2.0	1.6	0.3	3.25

¹⁾ Contact resistance max. 1.5 mΩ

²⁾ Contact resistance internal wire max. 3 mΩ

DIN 41 612 · Special contacts type M

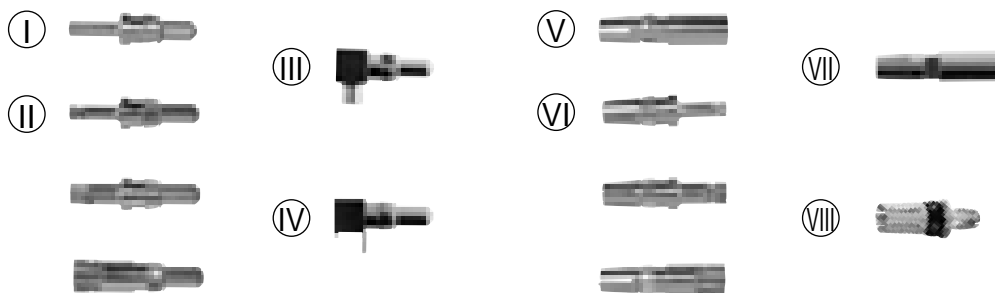

High current contacts

DIN Signal up to 2 A

Identification Part No. Performance level 1 Drawing Dimensions in mm

High current male contacts for male connectors¹⁾

Identification	Current	Part No.
I for straight crimp termination	10 A	09 03 000 6113
	20 A	09 03 000 6114
	40 A	09 03 000 6115
II for straight solder termination	10 A	09 03 000 6101
	20 A	09 03 000 6102
	40 A	09 03 000 6103
Leading contact	10 A	09 03 000 6111
	20 A	09 03 000 6122
	40 A	09 03 000 6133
III for angled pcb termination	max. 40 A*	09 03 000 6110
IV Leading contact	max. 40 A*	09 03 000 6104
	max. 40 A*	09 03 000 6134

acc. to DIN 41 626

	ø A	ø B	wire gauge [mm ²]	AWG
10 A	1.85	2.55	1.5	16
20 A	2.85	3.70	4	12
40 A	4.40	5.60	10	8

	ø
10 A	1.7
20 A	2.8
40 A	4.8

	x	y
... 6104	17.7	6.4
... 6134	18.4	7.0

High current female contacts for female connectors¹⁾

Identification	Current	Part No.
V for straight crimp termination	10 A	09 03 000 6213
	20 A	09 03 000 6214
	40 A	09 03 000 6215
VI for straight solder termination	10 A	09 03 000 6201
	20 A	09 03 000 6202
	40 A	09 03 000 6203
VII for screw fixing on busbar	40 A	09 03 000 6245
VIII for type M-flat for press-in termination	40 A	09 03 000 6250
	40 A	09 03 000 6225

acc. to DIN 41 626

	ø A	ø B	wire gauge [mm ²]	AWG
10 A	1.85	2.55	1.5	16
20 A	2.80	3.70	4	12
40 A	4.40	5.60	10	8

	ø
10 A	1.7
20 A	2.8
40 A	4.8

¹⁾ Contact resistance max. 1.5 mΩ
²⁾ Contact resistance internal wire max. 3 mΩ

Number of contacts

78+2, 60+4, 42+6, 24+8

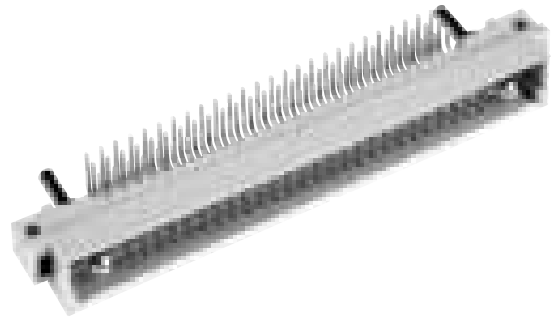

Male connectors

Identification	Number of contacts	Contact arrangement	Part No.	Performance levels according to IEC 60603-2. Explanation chapter 00		
				3	2	1
Male connector with angled solder pins (without special contacts)*	78 + 2		09 03 178 7901	09 03 178 6901 09 03 178 6901 222 ^{f)} 09 03 378 6901 ^{b)}	09 03 178 2901 09 03 378 2901 ^{b)}	
	60 + 4		09 03 160 7901	09 03 160 6901	09 03 160 2901	
	42 + 6		09 03 142 7901	09 03 142 6901	09 03 142 2901	
	24 + 8		09 03 124 7901	09 03 124 6901 09 03 124 6901 222 ^{f)}	09 03 124 2901	

Dimensions

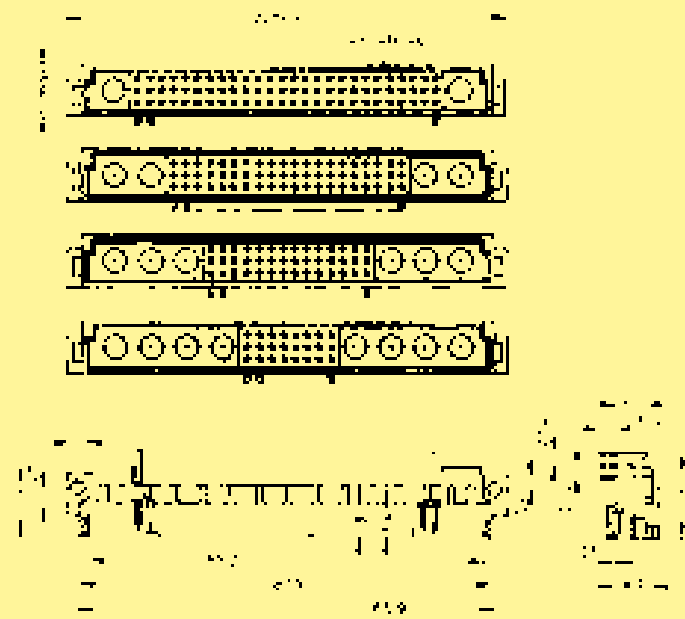

Angled solder pins

Order high current, high voltage, coaxial and fibre optic contacts separately, see pages 01.38 ff

Board drillings

Mounting side

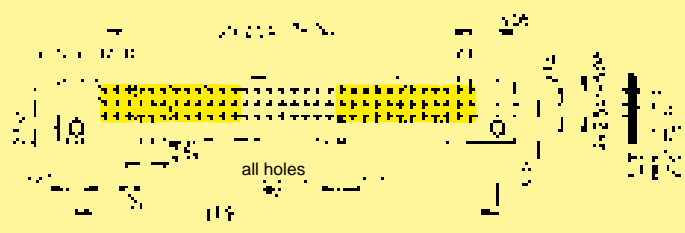

all holes

Board drillings depend on type and special contact loading

Dimensions in mm

DIN Signal up to 2 A

* Pre-loaded with special contacts on request
^{b)} Connectors with snap-in clips see chapter 00
^{f)} Railway classification NFF 16-101, Smoke index: F1, Flammability class: I2



Number of contacts

78+2, 60+4, 42+6, 24+8

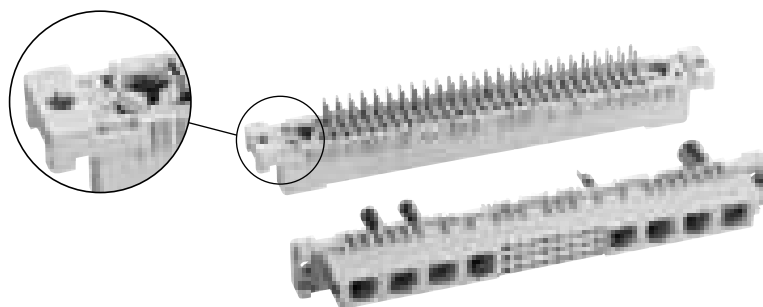

Female connectors

DIN Signal
up to 2 A

Identification	Number of contacts	Contact arrangement	Part No.	Performance levels according to IEC 60603-2. Explanation chapter 00					
				3	2	1			
Female connector with solder pins 2.9 mm (without special contacts)	78 + 2		Performance level 3 on request	Performance level 1 on request					
	60 + 4								
	42 + 6								
	24 + 8								
Female connector with solder pins 4.5 mm (without special contacts)	78 + 2						09 03 278 6804		
	60 + 4						09 03 260 6804		
	42 + 6						09 03 242 6804		
	24 + 8						09 03 224 6804		
Female connector with press-in pins 4.5 mm (without special contacts)	78 + 2						09 03 278 6805		
	60 + 4						09 03 260 6805		
	42 + 6						09 03 242 6805		
	24 + 8						09 03 224 6805		

Dimensions

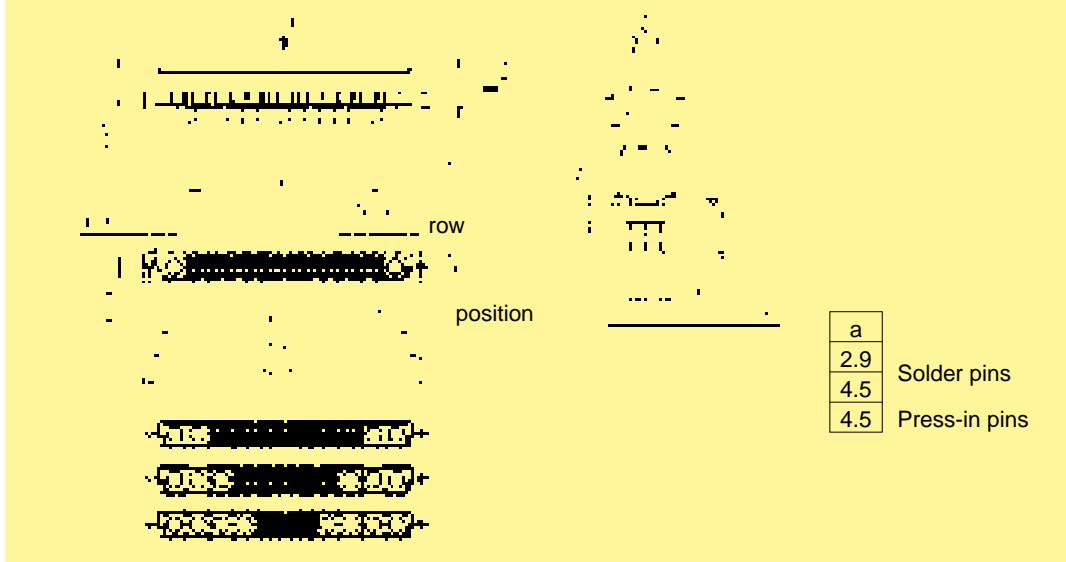

Order high current, high voltage, coaxial and fibre optic contacts separately, see pages 01.38 ff

Board drillings

Mounting side

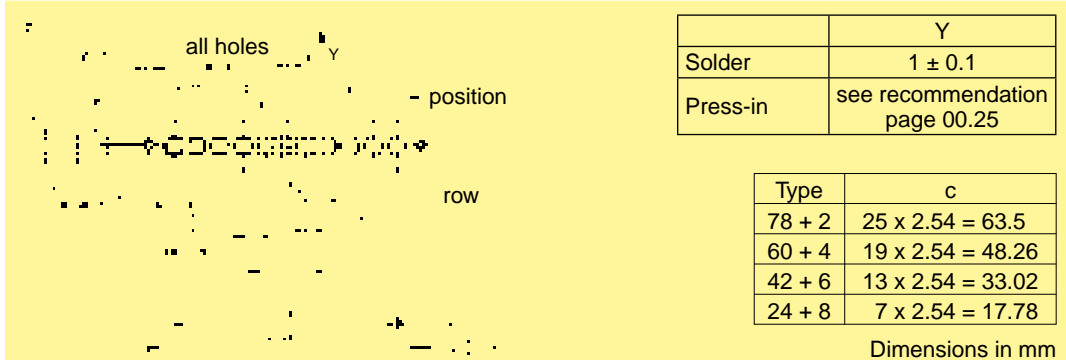

Board drillings depend on type and special contact loading

Other contact arrangements on request
 *) Railway classification NFF 16-101, Smoke index: F1, Flammability class: I2



Number of contacts

78+2, 60+4, 42+6, 24+8

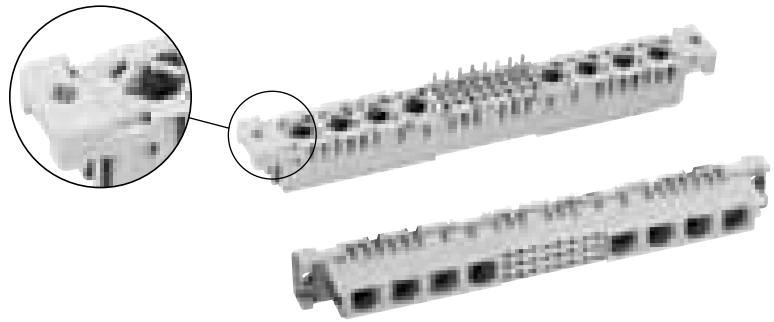

Female connectors

Identification	Number of contacts	Contact arrangement	Part No.	Performance levels according to IEC 60 603-2. Explanation chapter 00						
				3	2	1				
Female connector with solder pins 2.9 mm (without special contacts)*	78 + 2		Performance level 3 on request	09 03 278 6864		Performance level 1 on request				
	60 + 4			09 03 260 6864						
	42 + 6			09 03 242 6864						
	24 + 8			09 03 224 6864 09 03 224 6864 222 ^{f)}						
Female connector with solder pins 4.5 mm (without special contacts)*	78 + 2			Performance level 3 on request	09 03 278 6865		Performance level 1 on request			
	60 + 4				09 03 260 6865					
	42 + 6				09 03 242 6865					
	24 + 8				09 03 224 6865					
Female connector with press-in pins 4.5 mm (without special contacts)*	78 + 2				Performance level 3 on request			09 03 278 6830		Performance level 1 on request
	60 + 4							09 03 260 6830		
	42 + 6							09 03 242 6830		
	24 + 8							09 03 224 6830		

DIN Signal up to 2 A

Dimensions



Order high current, high voltage, coaxial and fibre optic contacts separately, see pages 01.38 ff

Board drillings

Mounting side

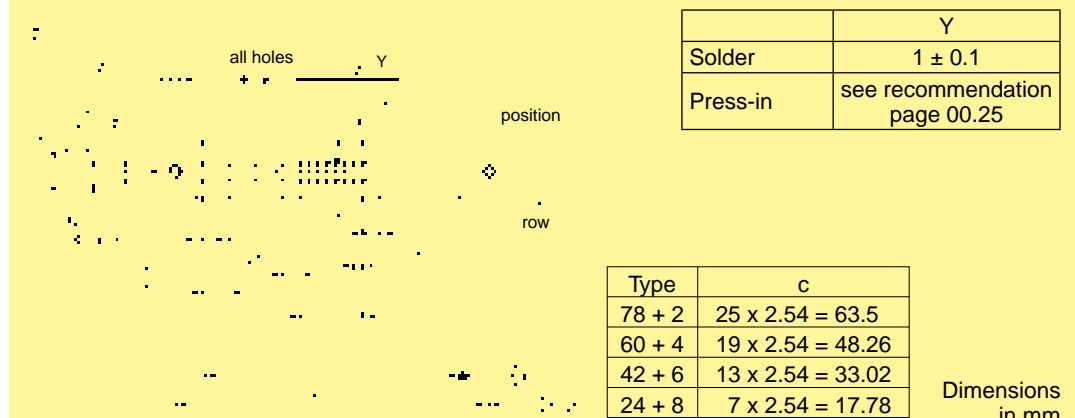

Board drillings depend on type and special contact loading

Dimensions in mm

* Pre-loaded with special contacts on request

^{f)} Railway classification NFF 16-101, Smoke index: F1, Flammability class: I2



Number of contacts

78+2, 60+4, 42+6, 24+8

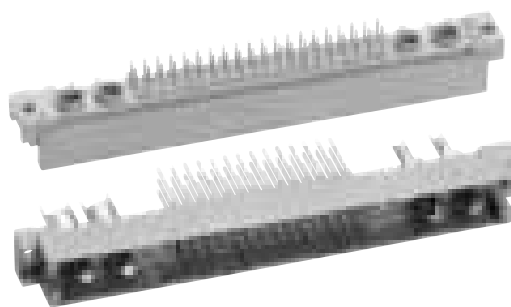

Male connectors

DIN Signal
up to 2 A

Identification	Number of contacts	Contact arrangement	Part No.	Performance levels according to IEC 60603-2. Explanation chapter 00		
				3	2	1
Male connector with solder pins 2.5 mm	78 + 2		Performance level 3 on request	09 73 178 6902	Performance level 1 on request	
	60 + 4			09 73 160 6902		
	42 + 6			09 73 142 6902		
	24 + 8			09 73 124 6902		
Male connector with solder pins 4.0 mm	78 + 2			09 73 178 6903		
	60 + 4			09 73 160 6903		
	42 + 6			09 73 142 6903		
	24 + 8			09 73 124 6903		
Male connector with wrap posts 13 mm	78 + 2			09 73 178 6907		
	60 + 4			09 73 160 6907		
	42 + 6			09 73 142 6907		
	24 + 8			09 73 124 6907		
Male connector with press-in pins 5.5 mm	78 + 2			09 73 178 6904		
	60 + 4			09 73 160 6904		
	42 + 6			09 73 142 6904		
	24 + 8			09 73 124 6904		
Male connector with press-in pins 13 mm	78 + 2		09 73 178 6985 09 73 178 6974●			
	60 + 4		09 73 160 6985 09 73 160 6974●			
	42 + 6		09 73 142 6985 09 73 142 6974●			
	24 + 8		09 73 124 6985			

Male connectors with 17 mm wrap posts on request
 ● Wrap posts for interfacing selectively gold plated (performance level 3)
 Other contact arrangements on request



Number of contacts

78+2, 60+4,
42+6, 24+8

Male connectors

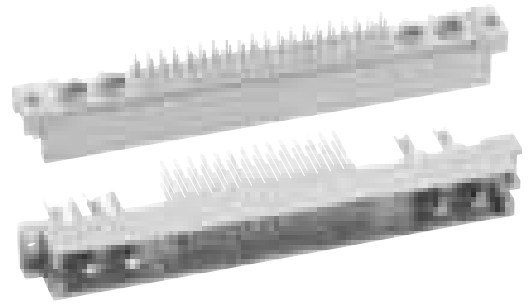

Identification

Drawing

Dimensions in mm

Dimensions

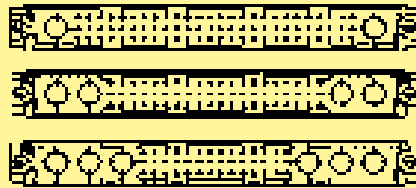

a	b	
2.5	ø 0.7	Solder pins
4.0		
13	□ 0.6	Wrap posts
5.5	–	Press-in pins
13	–	

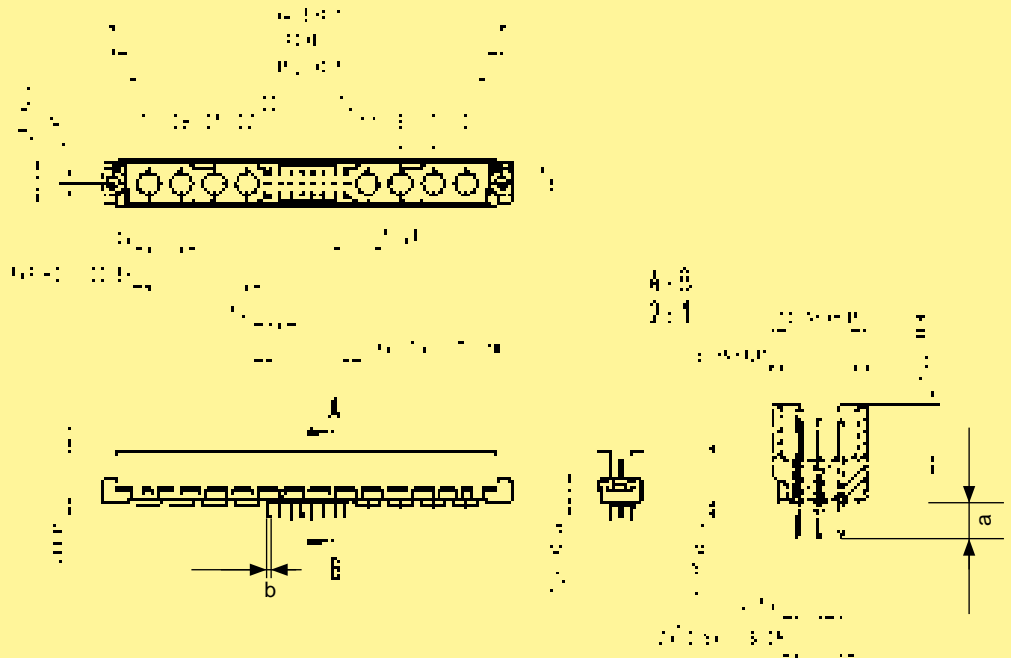

Order high current, high voltage, coaxial and fibre optic contacts separately, see pages 01.38 ff

Board drillings

Mounting side

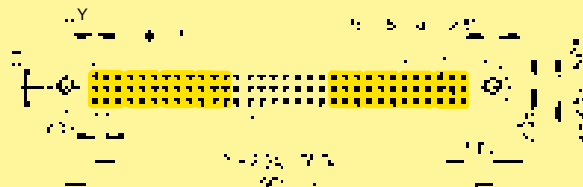

	Y
Solder	1 ± 0.1
Press-in	see recommendation page 00.25

Board drillings depend on type and special contact loading

DIN Signal up to 2 A



Number of contacts

96, 64

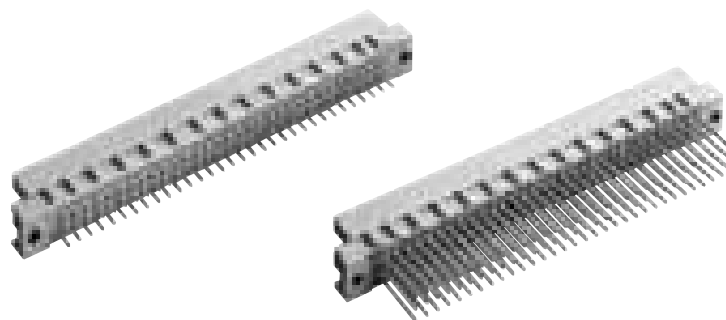

Male connectors

DIN Signal
up to 2 A

Identification	Number of contacts	Contact arrangement	Part No.	Performance levels according to IEC 60603-2. Explanation chapter 00		
				3	2	1
Male connector with solder pins 2.5 mm SMC	96		09 73 196 7902	09 73 196 6902 09 73 396 6902 ^{b)} 09 73 696 6902 ^{c)}	09 73 196 2902	
	96			09 73 196 6519 ^{d)}		
	64		09 73 164 7902	09 73 164 6902 09 73 364 6902 ^{b)}	09 73 164 2902 09 73 364 2902 ^{b)}	
Male connector with solder pins 4.0 mm SMC	96		09 73 196 7903	09 73 196 6903 09 73 196 6903 222 ^{f)} 09 73 396 6903 ^{b)} 09 73 196 6953	09 73 196 2903	
	94 + 2 [▲]			09 73 196 6520 ^{d)}		
	96					
Male connector with solder pins 13 mm SMC	64		09 73 164 7903	09 73 164 6903 09 73 364 6903 ^{b)}	09 73 164 2903	
	96			09 73 196 6577	09 73 196 2577	
	96			09 73 196 6521 ^{d)}		
Male connector with wrap posts ¹⁾ 13 mm	64		09 73 164 7907	09 73 164 6907 09 73 664 6947 ^{●c)}	09 73 164 2907	
	96		09 73 196 7907	09 73 196 6907 09 73 696 6947 ^{●c)}	09 73 196 2907	
	96			09 73 164 6907 09 73 164 6947 [●] 09 73 664 6947 ^{●c)}	09 73 164 2907	
Male connector with press-in pins 5.0 mm	64		09 73 164 7904	09 73 164 6904	09 73 164 2904	
	96		09 73 196 7904	09 73 196 6904 09 73 696 6904 ^{c)} 09 73 196 6954	09 73 196 2904	
	94 + 2 [▲]					
Male connector with press-in pins 13 mm	64		09 73 164 7974 [●]	09 73 164 6985 09 73 164 6974 [●]	Performance level 1 on request	
	96		09 73 196 7974 [●]	09 73 196 6985 09 73 196 6974 [●] 09 73 196 6995		
	94 + 2 [▲]			09 73 164 6985 09 73 164 6974 [●]		

▲ Male connectors with 2 leading contacts [(0.8 mm) pos. a1 and a32]
 ● Wrap posts for interfacing selectively gold plated (performance level 3)
 Other contact arrangements as well with lagging pins on request
^{f)} Railway classification NFF 16-101, Smoke index: F1, Flammability class: I2

¹⁾ To be used only for wire wrap termination
^{b)} Connectors with snap-in clips see chapter 00
^{c)} Connectors with coding see chapter 00
^{d)} CTI > 400

Number of contacts

96, 64

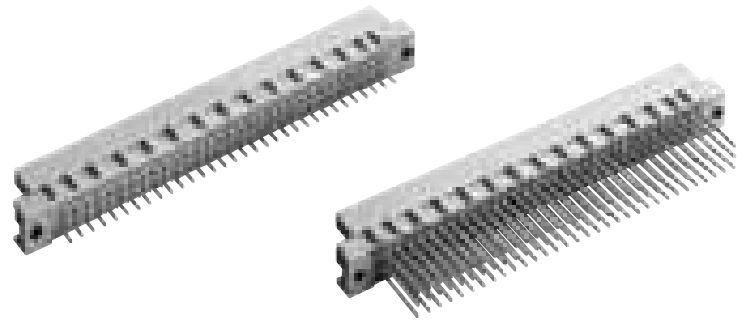

Male connectors

Identification

Drawing

Dimensions in mm

Dimensions

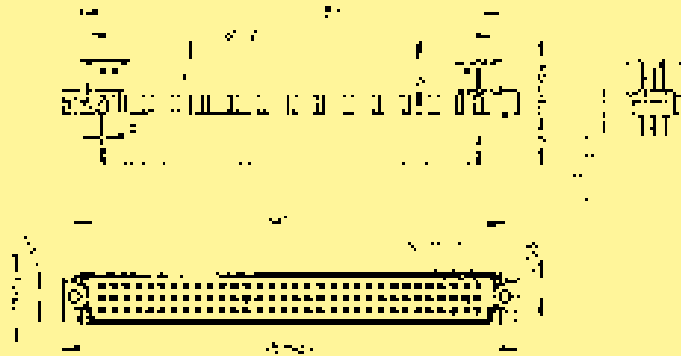

a	b
2.5	ø 0.7
4	
13	□ 0.6
13	□ 0.6
5	—
13	—

Solder pins
Wrap posts
Press-in pins

Panel cut out

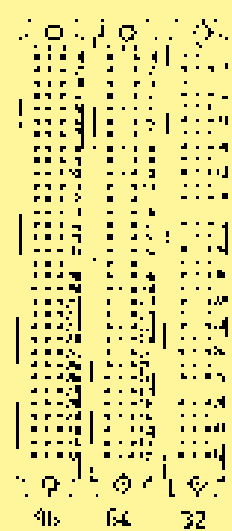
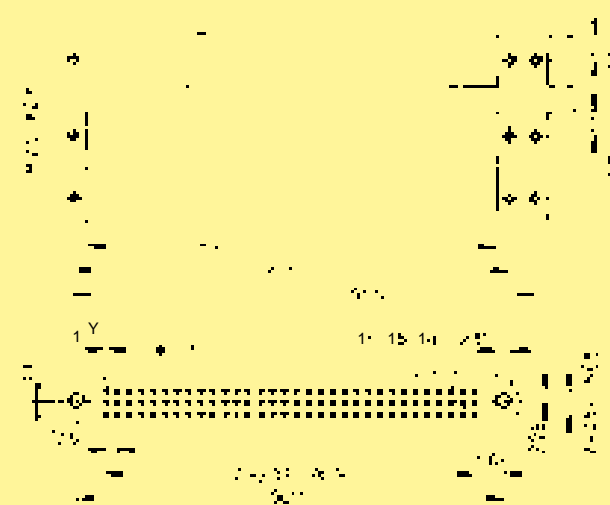

Contact arrangement
View from termination side

Board drillings
Mounting side

	Y
Solder	1 ± 0.1
Press-in	see recommendation page 00.25

Cross section of solder terminations

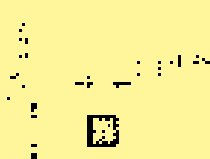

Cross area (A) of contacts row a, b, c: A = 0.35 - 0.39 mm²

DIN 41 612 · complementary type RM



Number of contacts

96, 64

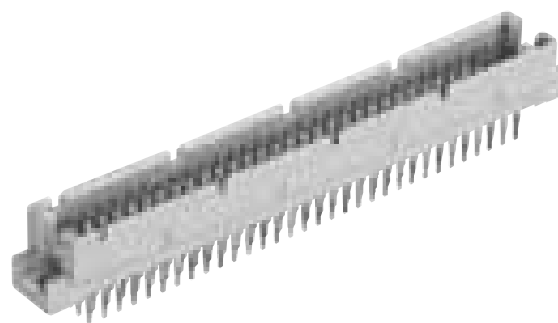

Male connectors

DIN Signal up to 2 A

Identification Number of contacts Contact arrangement Part No. Performance levels according to IEC 60 603-2. Explanation chapter 00

Identification	Number of contacts	Contact arrangement	Part No.	Performance levels according to IEC 60 603-2. Explanation chapter 00	2	1	
Male connector with press-in terminations	5.0 mm			Performance level 3 on request	Performance level 2 on request	09 79 196 2950	
		64					09 79 164 2950
	13 mm	96					09 79 196 2961*

Dimensions

a
5
13

Board drillings
Mounting side

01
48

Dimensions in mm

* Wrap posts for interfacing selectively gold plated (performance level 2)
 1) refer to recommended configuration of pcb holes, see page 00.25

Other contact arrangements also with lagging pins on request

Number of contacts

96, 64, 32

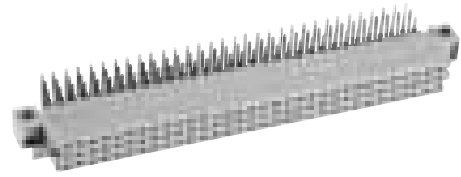

Female connectors

DIN Signal up to 2 A

Identification	Number of contacts	Contact arrangement	Part No. Performance levels according to IEC 60603-2. Explanation chapter 00			
			3	2	1	
Female connector with angled solder pins	96		09 73 296 7801	09 73 296 6801 09 73 296 6801 222 ^{f)}	09 73 296 2801	
			09 73 496 7801 ^{b)}	09 73 496 6801 ^{b)} 09 73 796 6801 ^{c)}		
	SMC	96			09 73 296 6804 ^{d)} 09 73 496 6804 ^{b)d)}	09 73 496 2804 ^{b)d)}
	SMC	64		09 73 264 7801 09 73 464 7801 ^{b)}	09 73 264 6801 09 73 464 6801 ^{b)}	09 73 264 2801
					09 73 264 6804 ^{d)} 09 73 464 6804 ^{b)d)}	09 73 264 2804 ^{d)} 09 73 464 2804 ^{b)d)}
32			09 73 232 7801	09 73 232 6801	09 73 232 2801	
				09 73 232 6811		

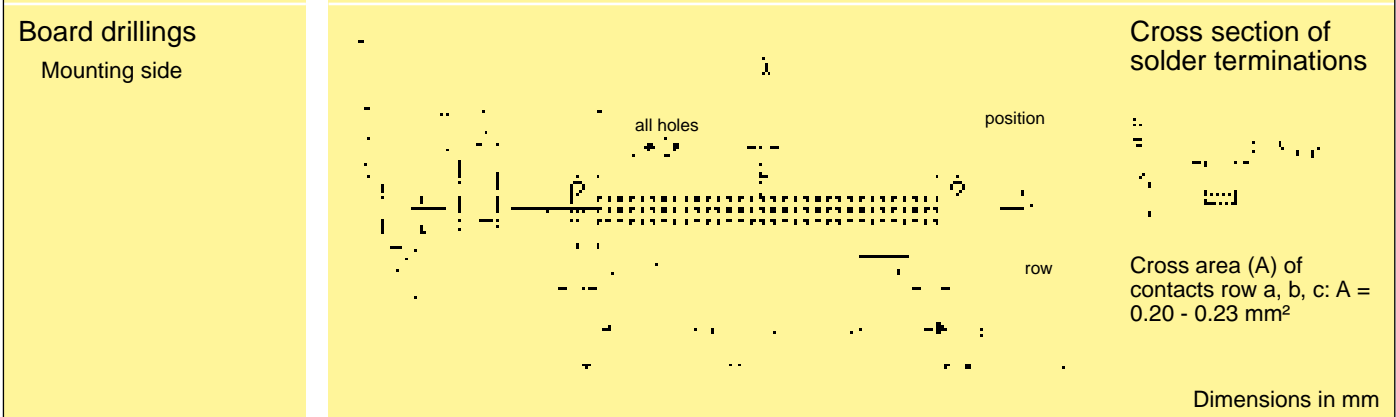
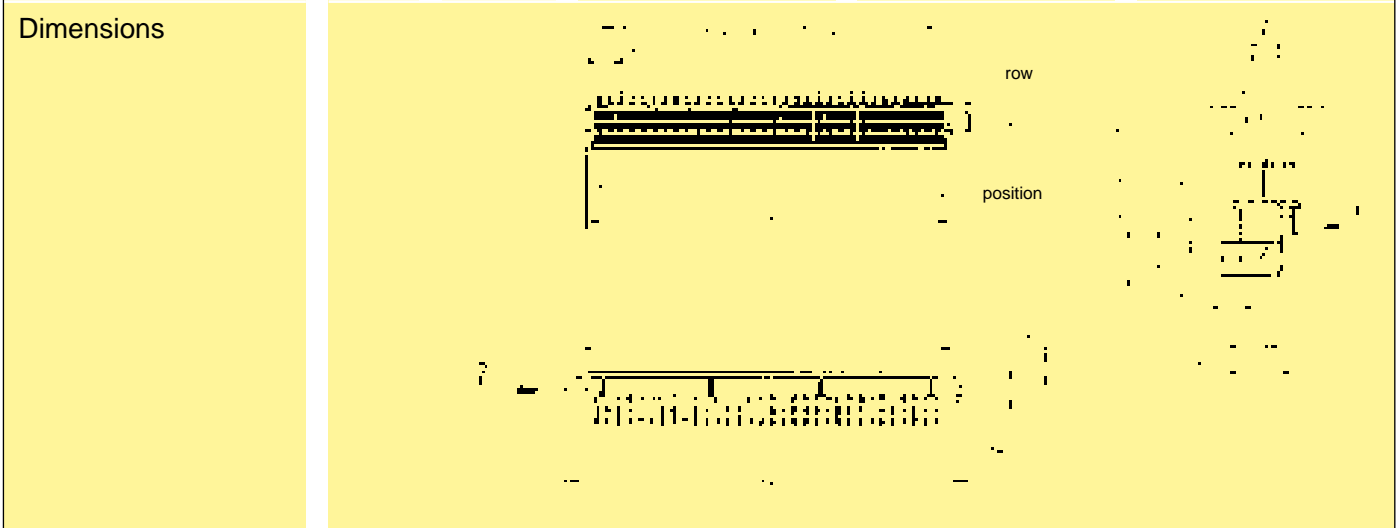

Other contact arrangements on request
^{b)} Connectors with snap-in clips see chapter 00
^{c)} Connectors with coding see chapter 00

^{d)} CTI > 400
^{f)} Railway classification NFF 16-101, Smoke index: F1, Flammability class: I2



Number of contacts

96, 64

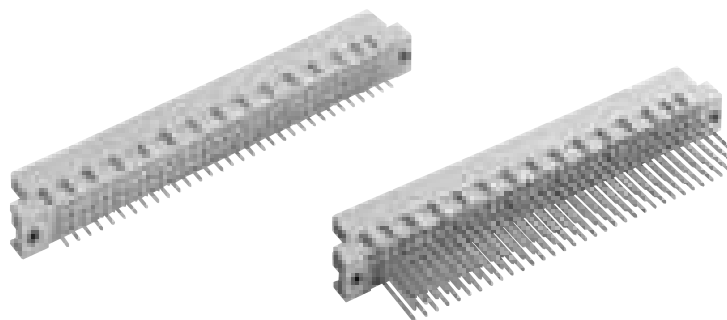

Male connectors

DIN Signal up to 2 A

Identification	Number of contacts	Contact arrangement	Part No.	Performance levels according to IEC 60603-2. Explanation chapter 00	3	2	1
Male connector with solder pins 2.5 mm	96		Performance level 3 on request	Performance level 3 on request	09 79 196 6902		
Male connector with solder pins 4.0 mm	96				09 79 196 6903 09 79 396 6903 ^{b)}		
	64				09 79 164 6903 09 79 364 6903 ^{b)}		
Male connector with wrap posts ¹⁾ 13 mm	96		09 79 196 6907				
	64		09 79 164 6907				

Dimensions

a	b	Solder pins
2.5	ø 0.7	
4		

a	b	Wrap posts
13	□ 0.6	

Panel cut out

Board drillings
Mounting side

Contact arrangement
View from termination side

96 64 32

Dimensions in mm

Other contact arrangements on request

= deviating dimensions from standard male connectors (see page 01.46f)

^{b)} Connectors with snap-in clips see chapter 00

¹⁾ To be used only for wire wrap termination



Number of contacts

96, 64

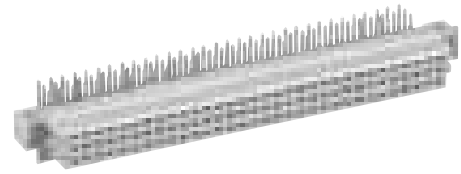

Female connectors

Identification	Number of contacts	Contact arrangement	Performance levels according to IEC 60603-2. Explanation chapter 00		
			3	2	1
Female connector with angled solder pins	96		09 79 296 7801	09 79 296 6801 09 79 496 6801 ^{b)}	Performance level 1 on request
	64		09 79 264 7801	09 79 264 6801 09 79 464 6801 ^{b)}	

DIN Signal up to 2 A

Dimensions

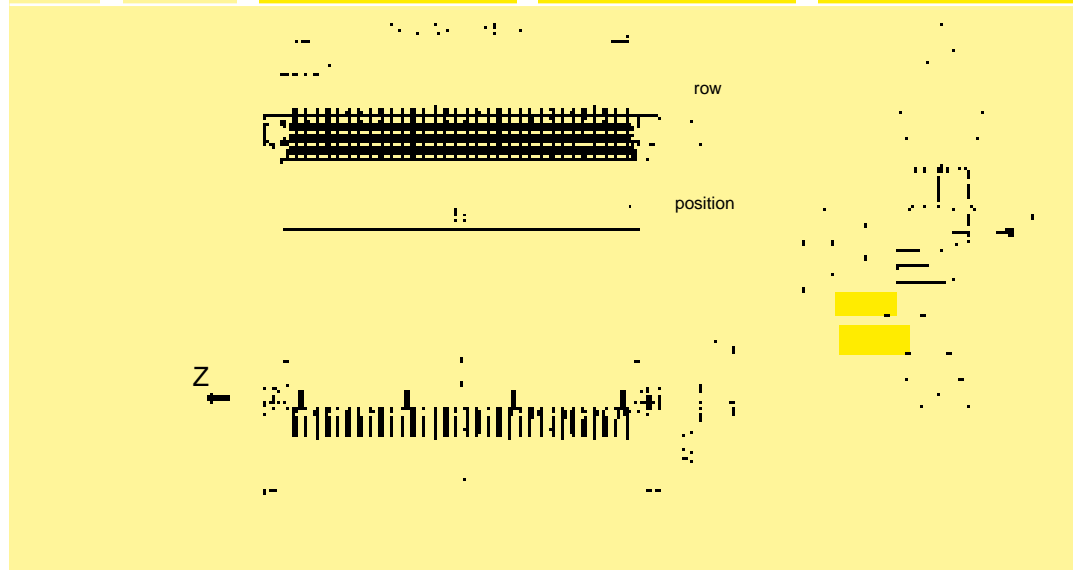

Board drillings

Mounting side

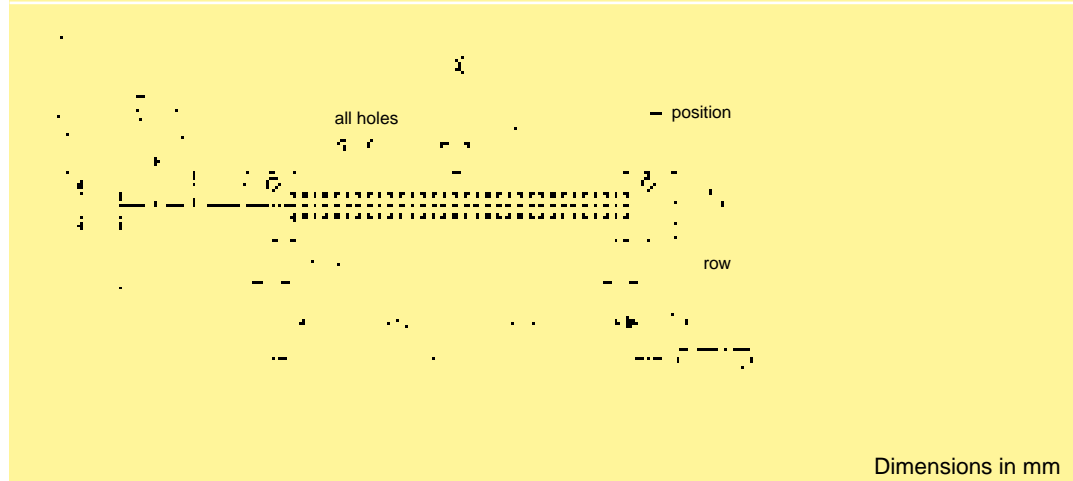

Dimensions in mm

Other contact arrangements on request

^{b)} Connectors with snap-in clips see chapter 00

= deviating dimensions from standard female connectors (see page 01.49)

Number of contacts

64

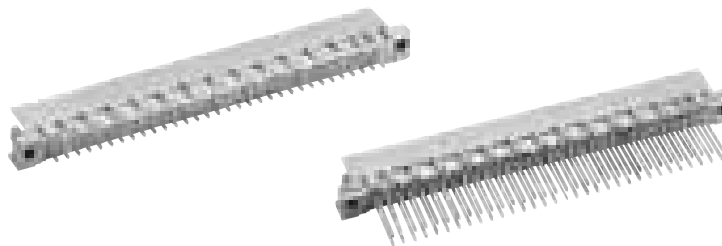

Male connectors

DIN Signal up to 2 A

Identification	Number of contacts	Contact arrangement	Part No.	Performance levels according to IEC 60603-2. Explanation chapter 00		
				3	2	1
Male connector with solder pins 2.5 mm	64		09 72 164 7902	09 72 164 6902 09 72 364 6902 ^{b)}	Performance level 1 on request	
	64		09 72 164 7903	09 72 164 6903		
	64			09 72 164 6577		
Male connector with wrap posts ¹⁾ 13 mm	64		09 72 164 7907	09 72 164 6907		
	64			09 72 164 6909		
Male connector with press-in pins 5.0 mm	64			09 72 164 6904 09 72 164 6904 222 ^{f)} 09 72 164 6954		
	62 + 2 [▲]			09 72 164 6985 09 72 164 6974* 09 72 164 6995		

Dimensions

a	b	
2.5	∅ 0.7	Solder pins
4		
13	∅ 0.6	Wrap posts
17	∅ 0.6	
5	–	Press-in pins
13	–	

Panel cut out

Board drillings
Mounting side

	Y
Solder	1 ± 0.1
Press-in	see recommendation page 00.25

Dimensions in mm

Other contact arrangements as well with lagging/leading pins on request
 ▲ Male connectors with 2 leading contacts (0.8 mm) pos. a1 and a32/a16
 • Wrap posts for interfacing selectively gold plated (performance level 3)

¹⁾ To be used only for wire wrap termination
^{b)} Connectors with snap-in clips see chapter 00
^{f)} Railway classification NFF 16-101, Smoke index: F1, Flammability class: I2

DIN 41 612 - complementary type 2Q



Number of contacts

32

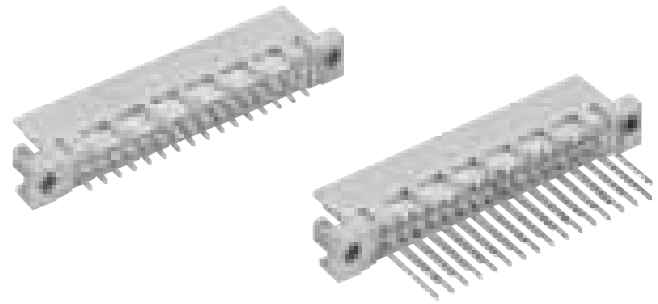

Male connectors

Identification	Number of contacts	Contact arrangement	Part No.	Performance levels according to IEC 60603-2. Explanation chapter 00		
				3	2	1
Male connector with solder pins 2.5 mm 4.0 mm 13 mm	32		09 27 132 7902 09 27 332 7902	09 27 132 6902	Performance level 1 on request	
	32		09 27 132 7903	09 27 132 6903 09 27 132 6903 222 ^{f)}		
	32			09 27 132 6577		
Male connector with wrap posts ¹⁾ 13 mm	32		09 27 132 7907	09 27 132 6907		
Male connector with press-in pins 5.0 mm	32 30 + 2 [▲]			09 27 132 6904 09 27 132 6954		

DIN Signal up to 2 A

Dimensions

a	b	
2.5	∅ 0.7	Solder pins
4		
13	□ 0.6	Wrap posts
13	□ 0.6	Press-in pins
5	—	

Panel cut out

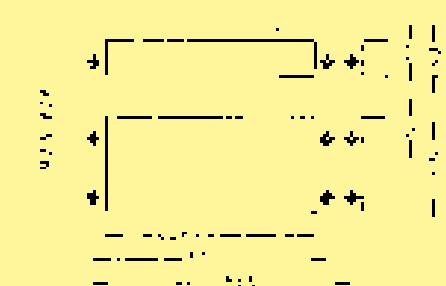

Board drillings

Mounting side

	Y
Solder	1 ± 0.1
Press-in	see recommendation page 00.25

Dimensions in mm

Other contact arrangements as well with lagging/leading pins on request
 ▲ Male connectors with 2 leading contacts (0.8 mm) pos. a1 and a32/a16
¹⁾ To be used only for wire wrap termination
^{f)} Railway classification NFF 16-101, Smoke index: F1, Flammability class: I2

DIN 41 612 · complementary type 2R



Number of contacts

48, 32



Male connectors

DIN Signal
up to 2 A

Identification	Number of contacts	Contact arrangement	Part No.	Performance levels according to IEC 60603-2. Explanation chapter 00		
				3	2	1
Male connector with solder pins 2.5 mm	48		09 28 148 7902 09 28 348 7902 ^{b)}	09 28 148 6902 09 28 348 6902 ^{b)}	09 28 148 2902	
						SMC
	32		09 28 132 7902	09 28 132 6902	09 28 132 2902	
						SMC
Male connector with solder pins 4.0 mm	48		09 28 148 7903	09 28 148 6903 09 28 148 6903 222 ^{f)} 09 28 348 6903 ^{b)}	09 28 148 2903	
						SMC
	32		09 28 132 7903	09 28 132 6903		
						SMC
Male connector with solder pins 13 mm	48			09 28 148 6577		
	48			09 28 148 6521 ^{d)}		
Male connector with wrap posts ¹⁾ 13 mm	48		09 28 148 7907	09 28 148 6907	09 28 148 2907	
	32		09 28 132 7907	09 28 132 6907	09 28 132 2907	
Male connector with press-in pins 5.0 mm	48		09 28 148 7904	09 28 148 6904 09 28 148 6904 222 ^{f)}		
	32					09 28 132 6904
Male connector with press-in pins 13 mm	48		09 28 148 7985	09 28 148 6985 09 28 148 6974 [•]		
	32					09 28 132 6985

01
54

• Wrap posts for interfacing selectively gold plated (performance level 3)

^{b)} Connectors with snap-in clips see chapter 00

¹⁾ To be used only for wire wrap termination

^{d)} CTI > 400

^{f)} Railway classification NFF 16-101, Smoke index: F1, Flammability class: I2

Number of contacts

48, 32



Male connectors

Identification

Drawing

Dimensions in mm

Dimensions

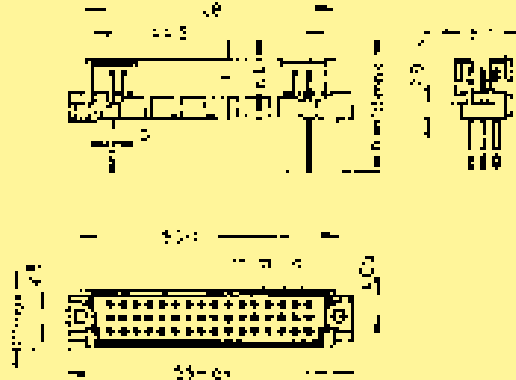

a	b
2.5	ø 0.7
4	
13	□ 0.6
13	□ 0.6
5	–
13	–

Solder pins

Wrap posts

Press-in pins

Panel cut out

Board drillings

Mounting side

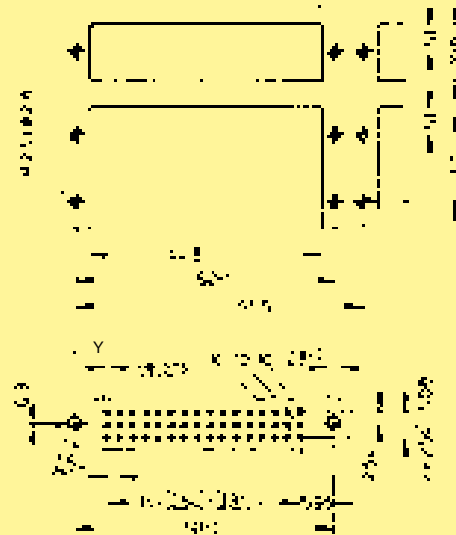

Contact arrangement
View from termination side

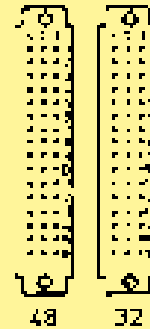

	Y
Solder	1 ± 0.1
Press-in	see recommendation page 00.25

Cross section of solder terminations

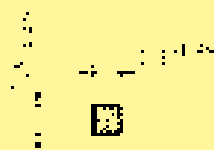

Cross area (A) of contacts row a, b, c: $A = 0.35 - 0.39 \text{ mm}^2$

DIN 41 612 · Type Q – complementary types 2Q, 2R



Number of contacts

64, 48, 32

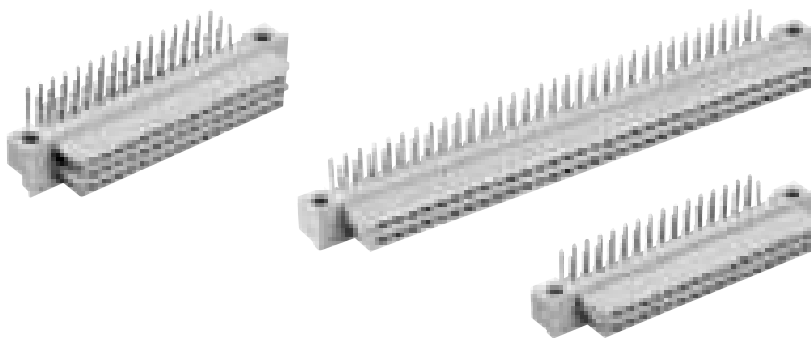

Female connectors

DIN Signal up to 2 A

Identification	Number of contacts	Contact arrangement	Part No. Performance level 2 according to IEC 60 603-2. Explanation chapter 00
Female connector with angled solder pins Type Q	64		09 72 264 6801 09 72 464 6801 ^{b)}
Type 2Q	32		09 27 232 6801
Type 2R	48		09 28 248 6801 09 28 448 6801 ^{b)}

Dimensions

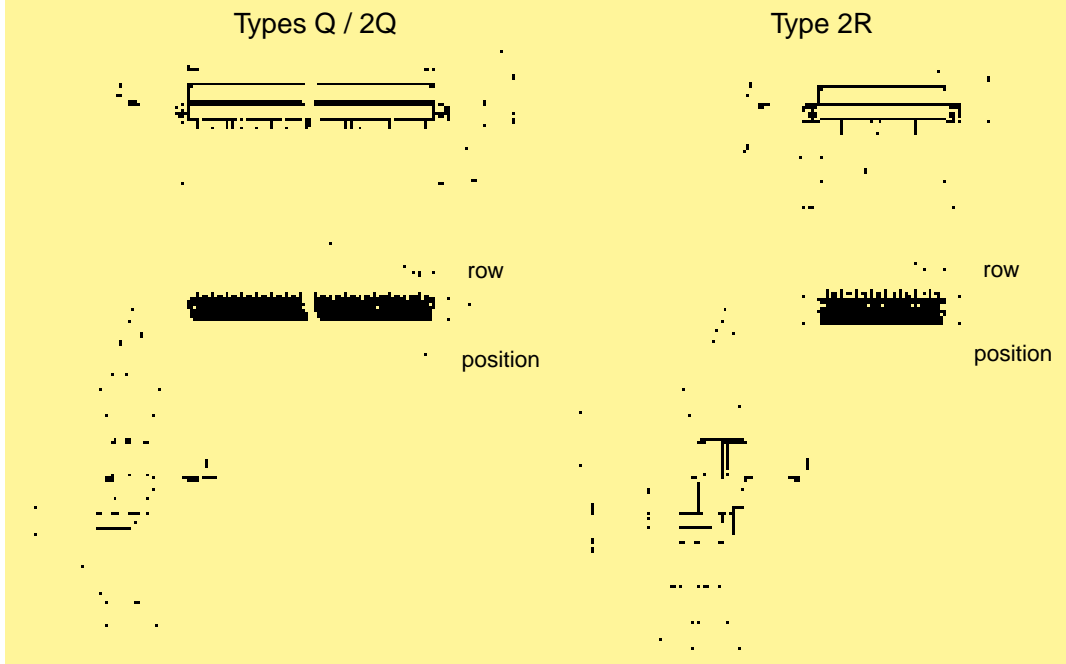

Type	a	b	c	d	e	f
Q	85.0 ^{-0.2}	88.90 ^{±0.1}	94.0 ^{-0.2}	31	78.74	32
2Q	44.4 ^{-0.2}	48.26 ^{±0.1}	53.9 ^{-0.2}	15	38.10	16

Board drillings

Mounting side

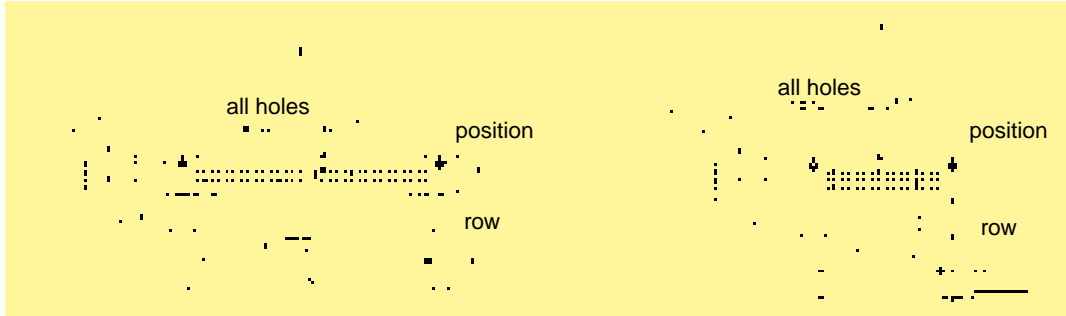

Dimensions in mm

Other contact arrangements on request

^{b)} Connectors with snap-in clips see chapter 00

Number of contacts

96, 48

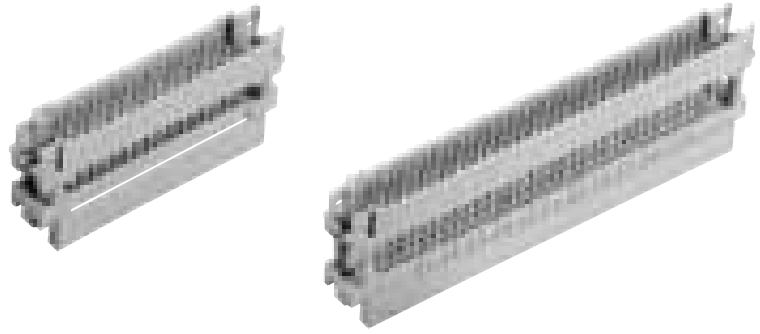

Mezzanine Adapter

Identification	Number of contacts	Contact arrangement	Part No.	Performance levels according to IEC 60 603-2.		
				3	2	1
Male connector type R with pin shroud for pcb distance 41 mm	96		Performance level 3 on request			09 73 196 5531
Male connector type 2R with pin shroud for pcb distance 41 mm 37.5 mm	48			09 28 148 6532	09 28 148 5531	

DIN Signal up to 2 A

Dimensions

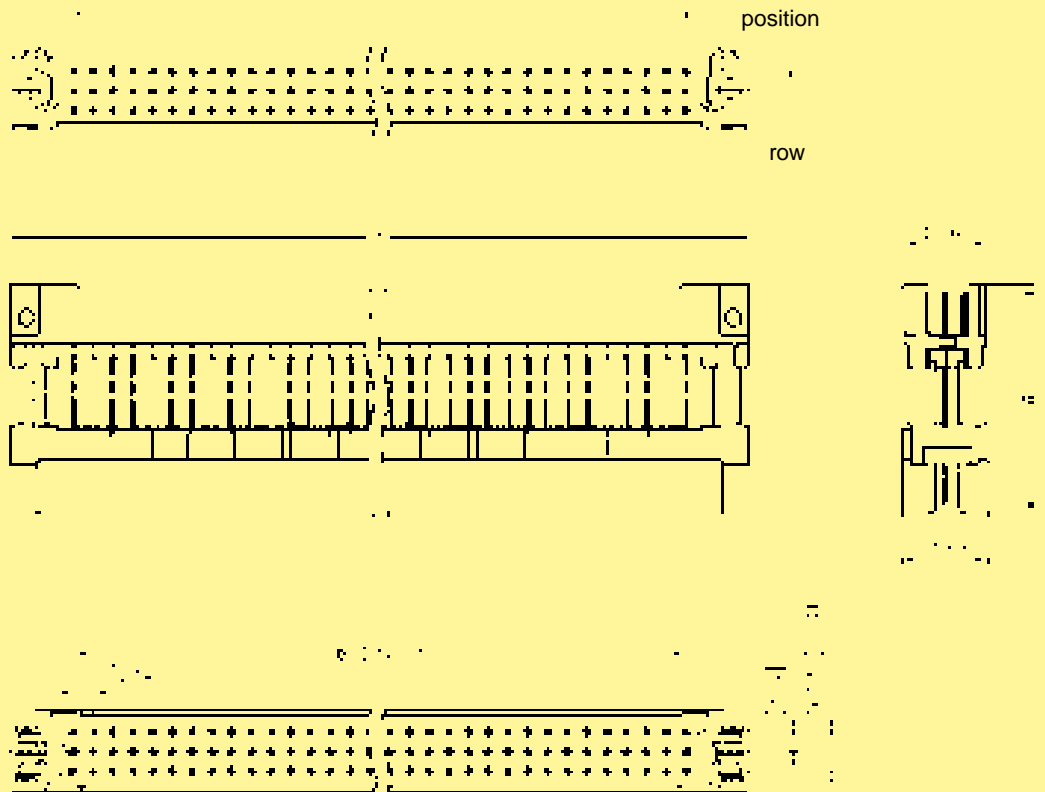

	a	b	c	d
09 73 196 5531	94.9 ± 0.1	31	78.74	29.6 ± 0.3
09 28 148 5531	54.9 ± 0.1	15	38.1	29.6 ± 0.3
09 28 148 6532	54.9 ± 0.1	15	38.1	26.15 ± 0.3

Dimensions in mm

Pin shroud



Number of contacts

96, 48

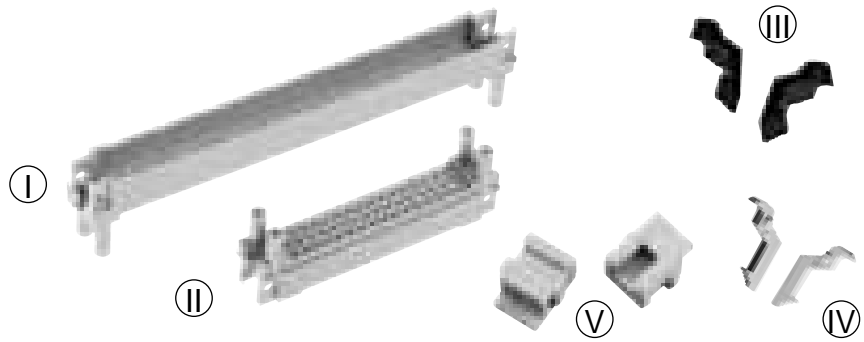

Pin shrouds
for types C, 2C, R, 2R

DIN Signal
up to 2 A

Identification	Termination length ± 0.3	pcb-thickness ± 0.4	Dimension a ± 0.1	Part No. – Pin shrouds with	
				press-in fixing ¹⁾	screw fixing
Pin shrouds for female connectors type C, R ①	13.0/ 13.2	1.6	6.7	09 03 000 9956	09 03 000 9966
		2.4	5.9	09 03 000 9957	09 03 000 9967
		3.2	5.1	09 03 000 9958	09 03 000 9968
		4.0	4.3	09 03 000 9959	09 03 000 9969
	17.0	1.6	9.9	09 03 000 9952	09 03 000 9962
		2.4	9.1	09 03 000 9953	09 03 000 9963
		3.2	8.3	09 03 000 9954	09 03 000 9964
		4.0	7.5	09 03 000 9955	09 03 000 9965
		4.8	6.7	09 03 000 9956	09 03 000 9966
		5.6	5.9	09 03 000 9957	09 03 000 9967
		6.4	5.1	09 03 000 9958	09 03 000 9968
	20.0	3.2	11.75	09 03 000 9950	09 03 000 9960
		4.0	10.7	09 03 000 9951	09 03 000 9961
		4.8	9.9	09 03 000 9952	09 03 000 9962
		5.6	9.1	09 03 000 9953	09 03 000 9963
		6.4	8.3	09 03 000 9954	09 03 000 9964
		7.2	7.5	09 03 000 9955	09 03 000 9965
Pin shrouds for female connectors type 2C, 2R ②	13.0/ 13.2	1.6	6.7	09 23 000 9956	09 23 000 9966
		2.4	5.9	09 23 000 9957	09 23 000 9967
		3.2	5.1	09 23 000 9958	09 23 000 9968
		4.0	4.3	09 23 000 9959	09 23 000 9969
	17.0	1.6	9.9	09 23 000 9952	09 23 000 9962
		2.4	9.1	09 23 000 9953	09 23 000 9963
		3.2	8.3	09 23 000 9954	09 23 000 9964
		4.0	7.5	09 23 000 9955	09 23 000 9965
		4.8	6.7	09 23 000 9956	09 23 000 9966
		5.6	5.9	09 23 000 9957	09 23 000 9967
		6.4	5.1	09 23 000 9958	09 23 000 9968
	20.0	3.2	11.75	09 23 000 9950	09 23 000 9960
		4.0	10.7	09 23 000 9951	09 23 000 9961
		4.8	9.9	09 23 000 9952	09 23 000 9962
		5.6	9.1	09 23 000 9953	09 23 000 9963
		6.4	8.3	09 23 000 9954	09 23 000 9964
		7.2	7.5	09 23 000 9955	09 23 000 9965

Identification	Part No.
Locking lever for female connectors type C, 2C* ③	09 03 000 9914
Locking lever for female connectors type R, 2R* ④	09 03 000 9913
Fixing bracket for shell housing C* ⑤	09 03 000 9921

* order 2 pieces per connector

¹⁾ Tooling see chapter 30

Pin shroud



Number of contacts

96, 48

Pin shrouds
for types C, 2C, R, 2R

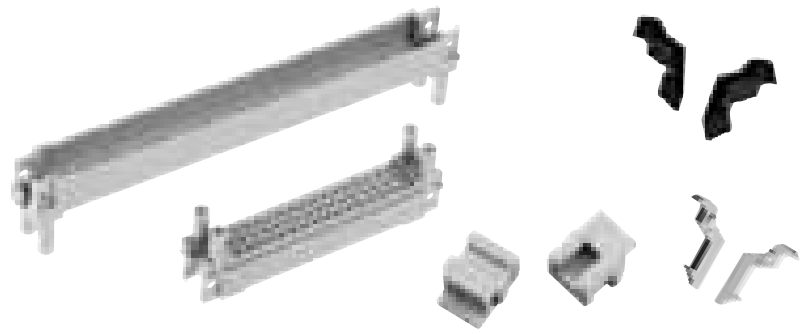

Identification

Drawing

Dimensions in mm

Pin shrouds
for female connectors
type C, R

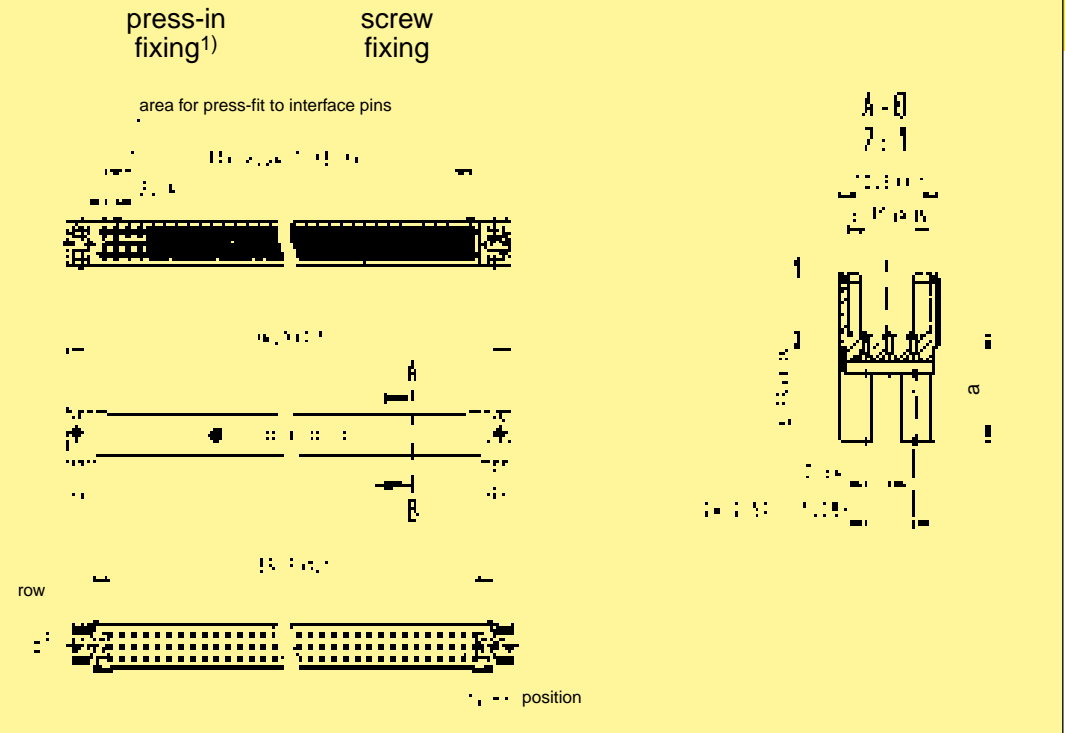

Pin shrouds
for female connectors
type 2C, 2R

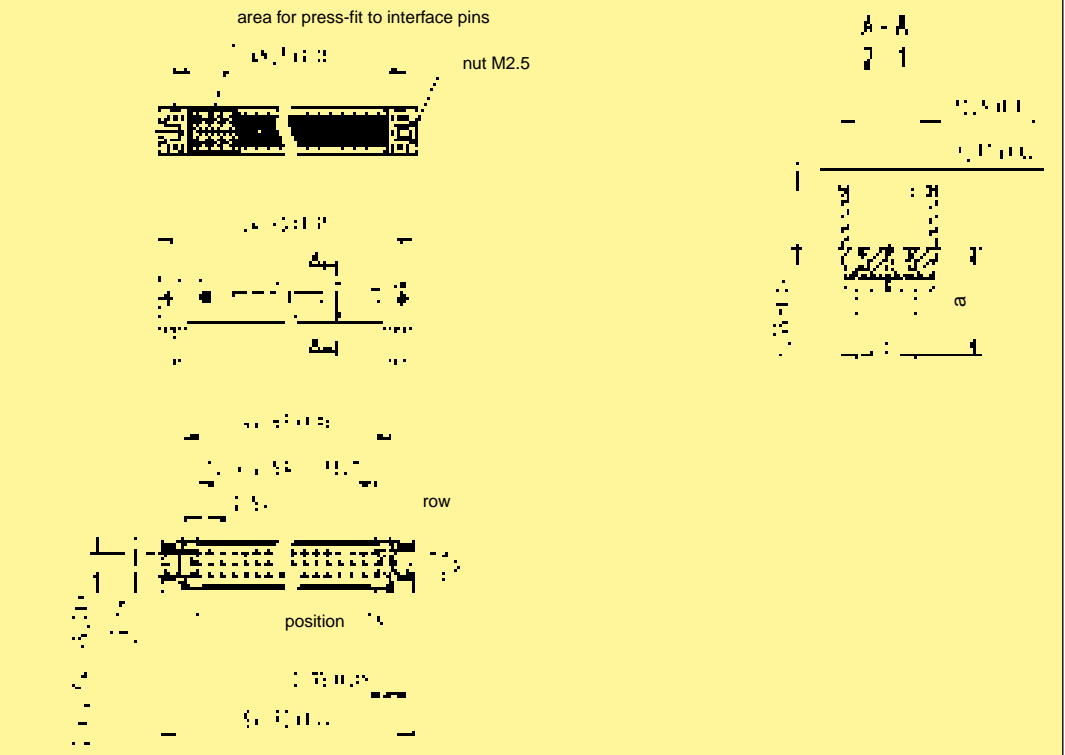

DIN Signal
up to 2 A

¹⁾ Tooling see chapter 30

Application 1

Female connector
09 03 296 6861



Backplane

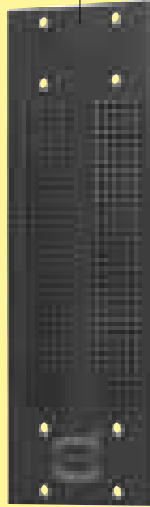

Pin shroud
09 03 000 9957



Locking lever
09 03 000 9914



Female connector
09 03 264 6828



Female connector
09 03 096 3214



Application 2

Female connector
09 03 296 6862



Backplane

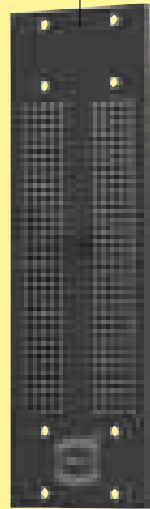

Pin shroud
09 03 000 9953



Locking lever
09 03 000 9913



Female connector
09 73 296 6801

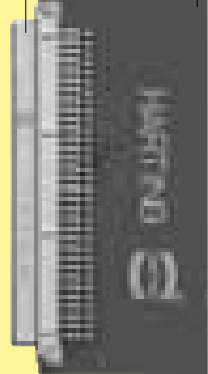

Daughtercard

Application 3

Female connector
09 03 296 6861

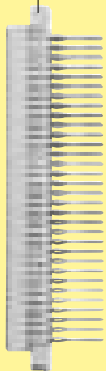

Backplane

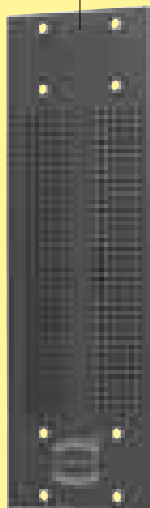

Pin shroud
09 03 000 9957



Fixing brackets
09 03 000 9921



Female connector
09 03 096 3214



Locking levers
left 09 02 000 9902
right 09 02 000 9903

Shell housing C
09 03 096 0501

DIN Signal
up to 2 A

Application 4

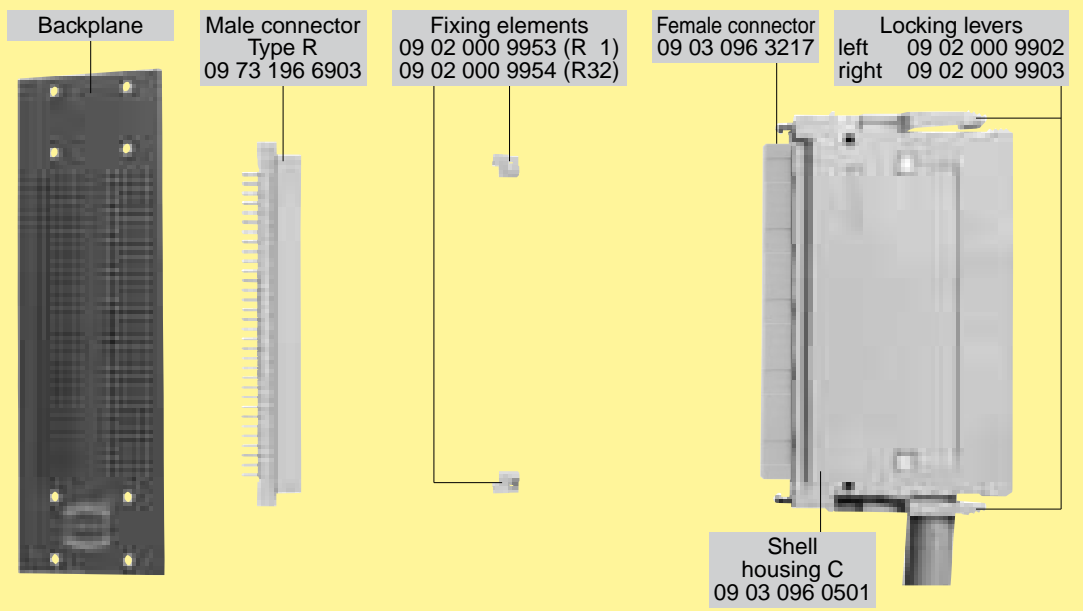

DIN Signal
up to 2 A

Application 5*

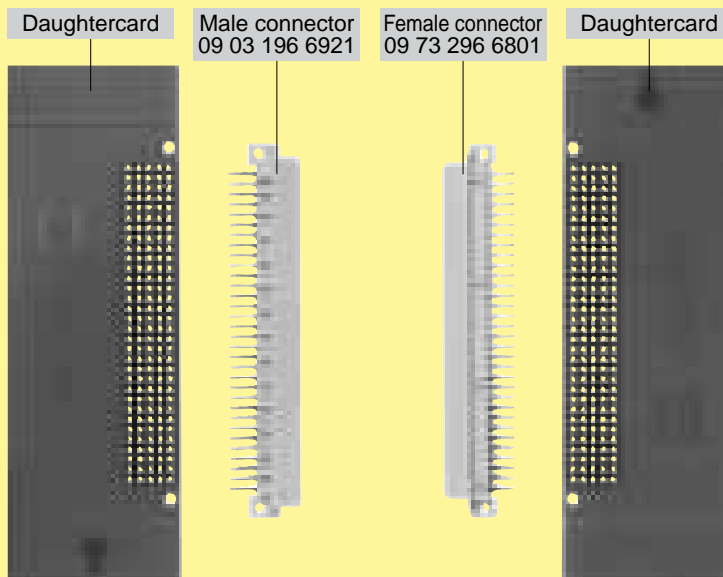

Application 6*

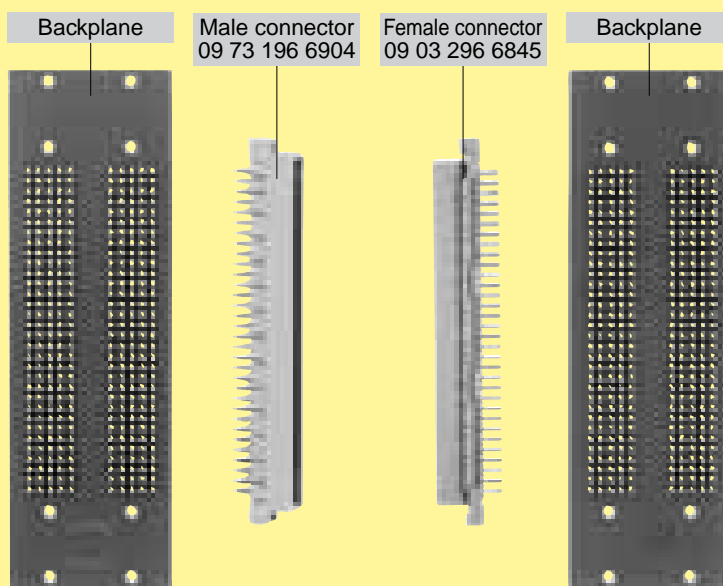

* Position marking turned: a1 contacts a32, a2 contacts a31, ...

Application 7

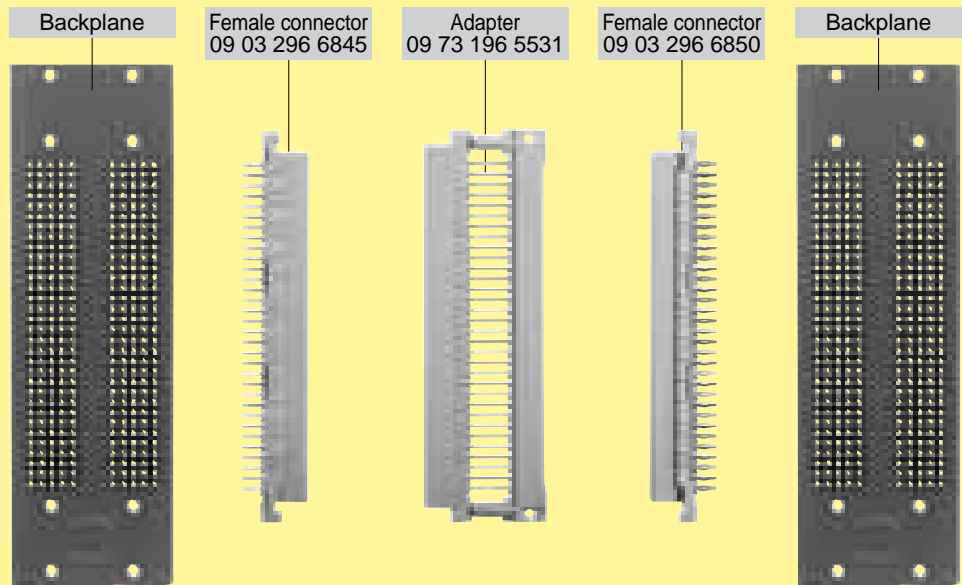
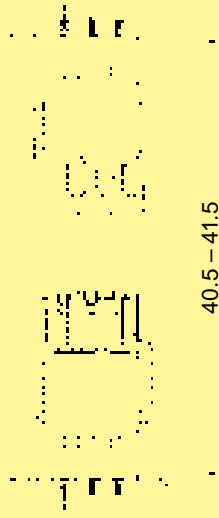

Application 8

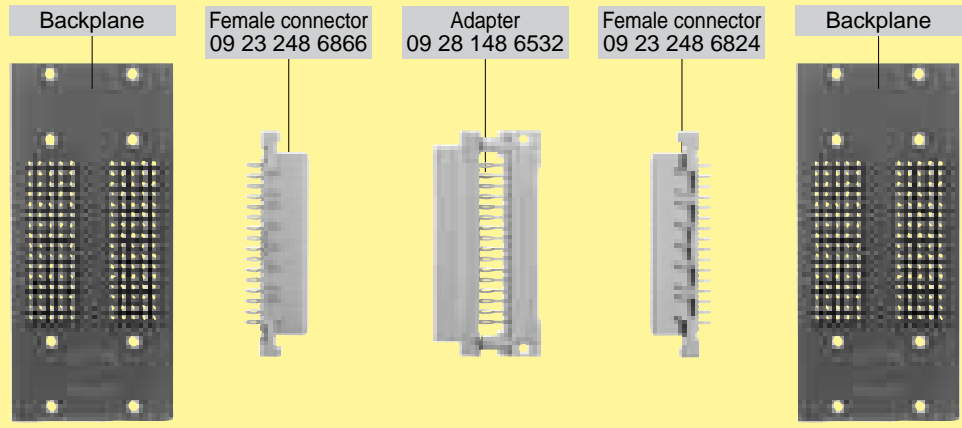
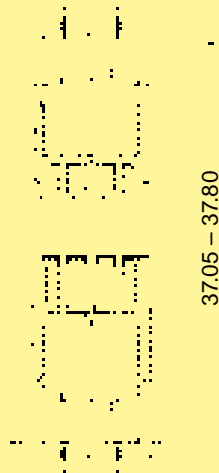

Application 9

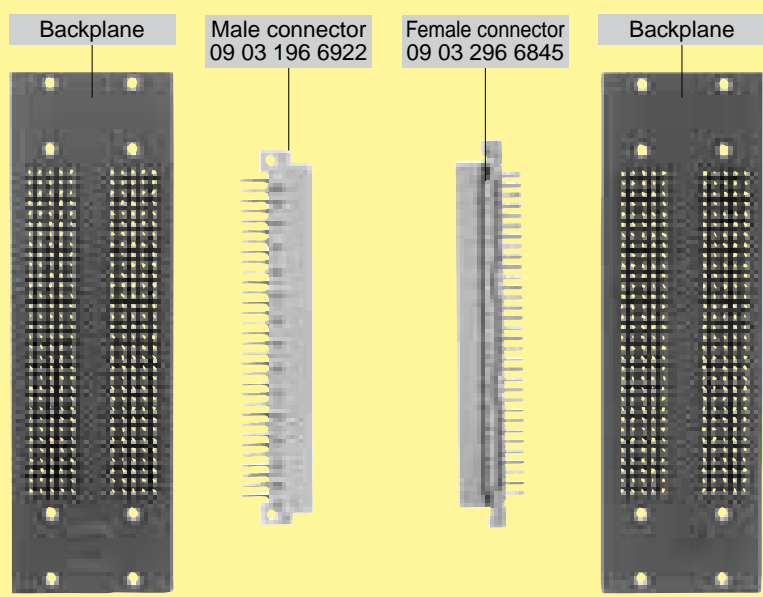
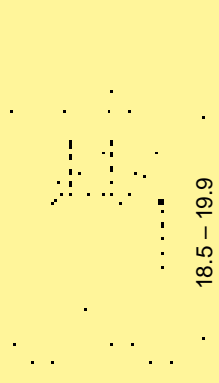

DIN Signal
up to 2 A

Arbus 64

Page

VMEbus systems **02.02**

Arbus 64

System description **02.03**

Technical characteristics **02.10**

Male connectors **02.11**

Female connectors **02.12**

Pin shrouds **02.16**

Application examples **02.17**

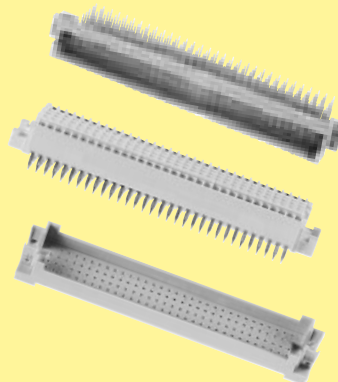

The past 20 years the VMEbus has reached a dominant position for industrial busses with a number of suppliers.

Despite numerous new bus systems based on the rapid changes in chip technology, VMEbus systems offer significant advantages such as their robustness, reliability and increased availability of processor, memory and I/O cards.

Additional advantages appear under real-time conditions, where unforeseen events have to be managed. This is realised with the program interrupt concept and variable control that closely monitors the bus system.



With the increase in processing speeds and data transmission rates, 3 row DIN 41612 connectors have reached their limit, so the VME standard needs to be enhanced further.

When VME architecture was increased from 8-bit to 64-bit and data transmission rates up to 160 Mbyte/s (VME 64x), HARTING introduced **bus 64** with 160 pins. This Eurocard connector is 100 % backwards compatible to existing 3 row connectors with 96 contacts, therefore old can plug into new.

To offer the best design possible from the start, HARTING developed spice models that were later certified via signal integrity measurements of the connector.

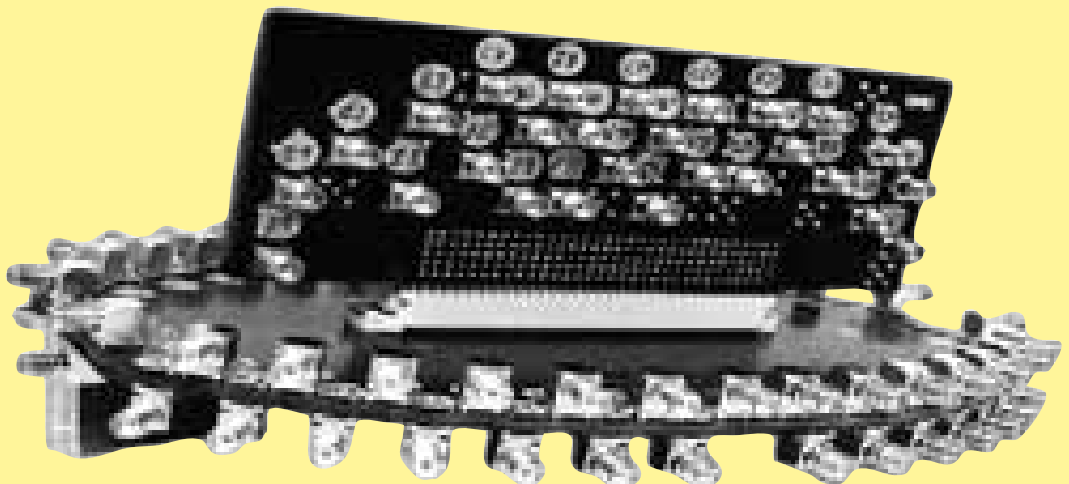

High precision slot structure with VME pinning for connector characterisation.

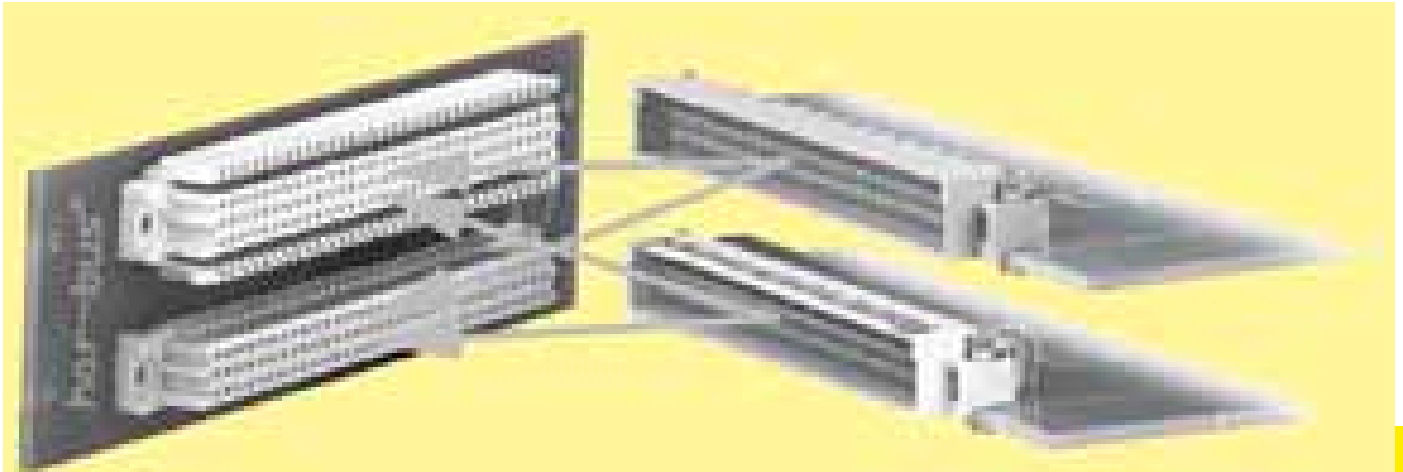

Backward compatibility

The design of **haribus 64** female connectors allows mating of any combinations of the 5 or 3 row versions without mechanical interference, thus making it possible for users to upgrade and maintain existing systems at lower costs. It is also possible to mate 5 row male connectors with 3 row female connectors.

The feature of backward compatibility allows a gradual upgrade of existing Eurocard based systems without the additional cost of a complete system redesign. It is not necessary to replace conventional 96 pin based boards as they remain pluggable into the 160 pin based systems.

Not only VMEbus, but also existing proprietary bus systems for which 3 row 96 pin connectors are no longer performance sufficient, **haribus 64** provides the opportunity to adapt the system economically without a complete redesign to a new bus architecture.

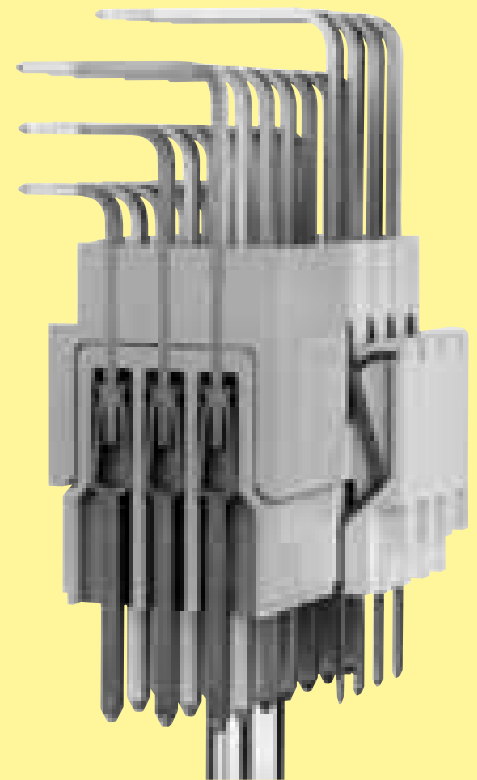

haribus 64 – five rows – 160 poles

Two additional rows of contacts in the **haribus 64** connector offer new system features:

- Additional contacts for I/O and system upgrade
- New voltage supplies for 3.3 V and 48 V system components
- Identifying locations of system components and the bus length. "Plug & Play"
- Improved signal/ground ratio for reliable signal data transfer at rates up to 320 MByte/s
- Live Insertion for replacing processor or memory cards without closing down the system
- User defined pins for test and maintenance bus lines

The advantages of **haribus 64** in detail

User-defined pins in the outer rows can be used for application specific functions such as **additional I/O**. Configured as a shield to provide larger ground return paths, they assure for **data transfer rates up to 320 MByte/s**.

Proprietary bus systems can utilise the new contact rows to optimise signal-to-ground ratios and improve system speed.

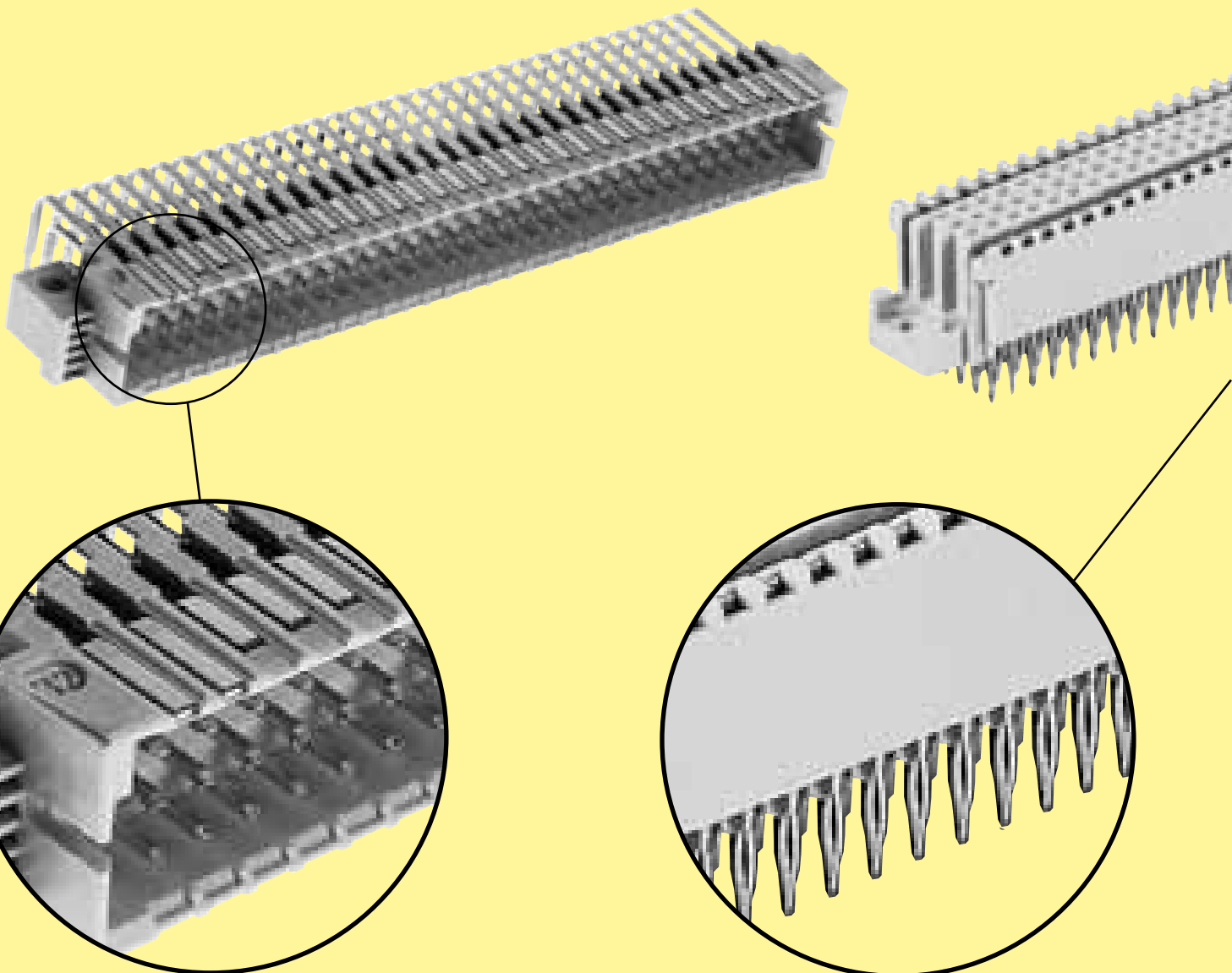

Four preleading contacts (1.5 mm) serve to pre-load the transmit and receive logic so that the bus will not experience glitches during **live insertion** of new cards into the backplane.

Backplane connector terminations are designed in solderless **press-in technology**.

The connector can be installed without any special tooling using economical **flat dies** for high speed insertion.

The insulator, made of LCP, has an inherent flammability rating of UL 94-V0 and therefore provides an **environment friendly** connector. In addition, the heat deformation stability of LCP makes the connector **surface-mount compatible** (see chapter 00).

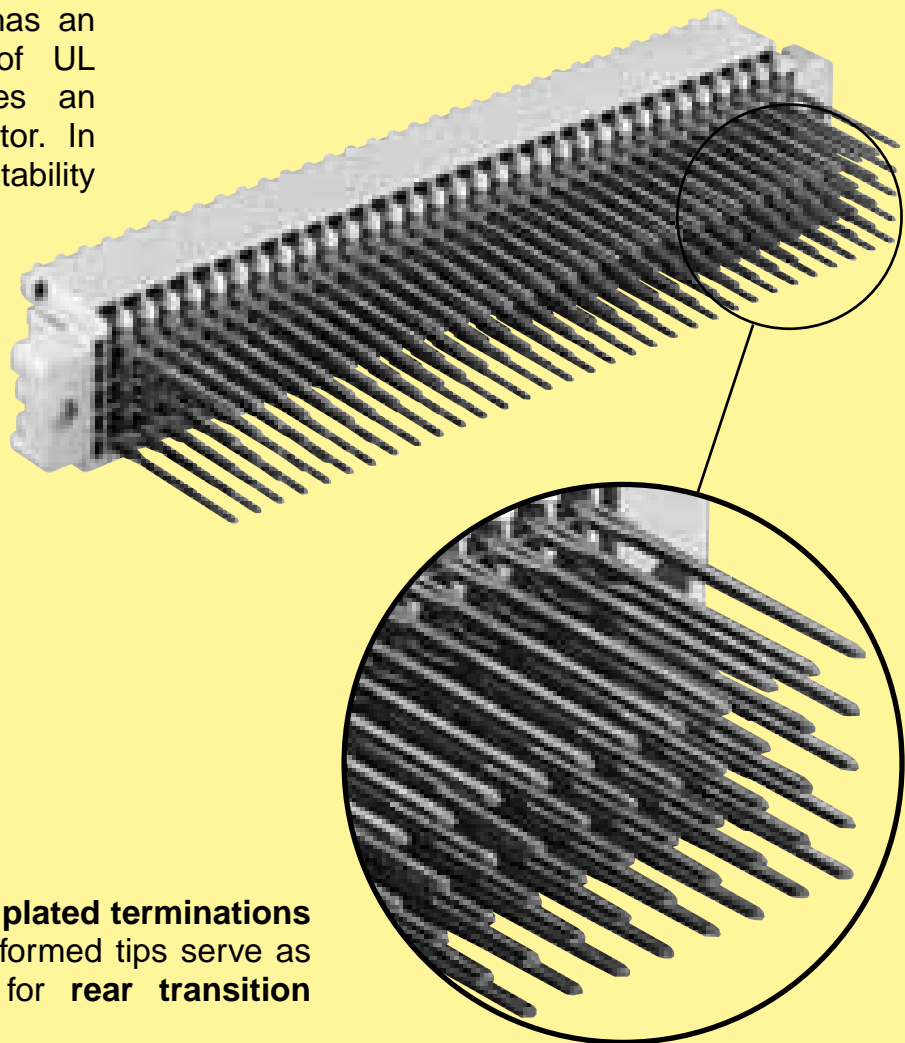
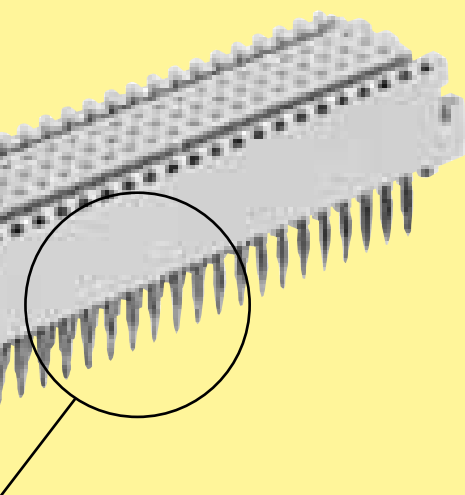

Partially gold plated terminations with precisely formed tips serve as contact area for **rear transition boards**.

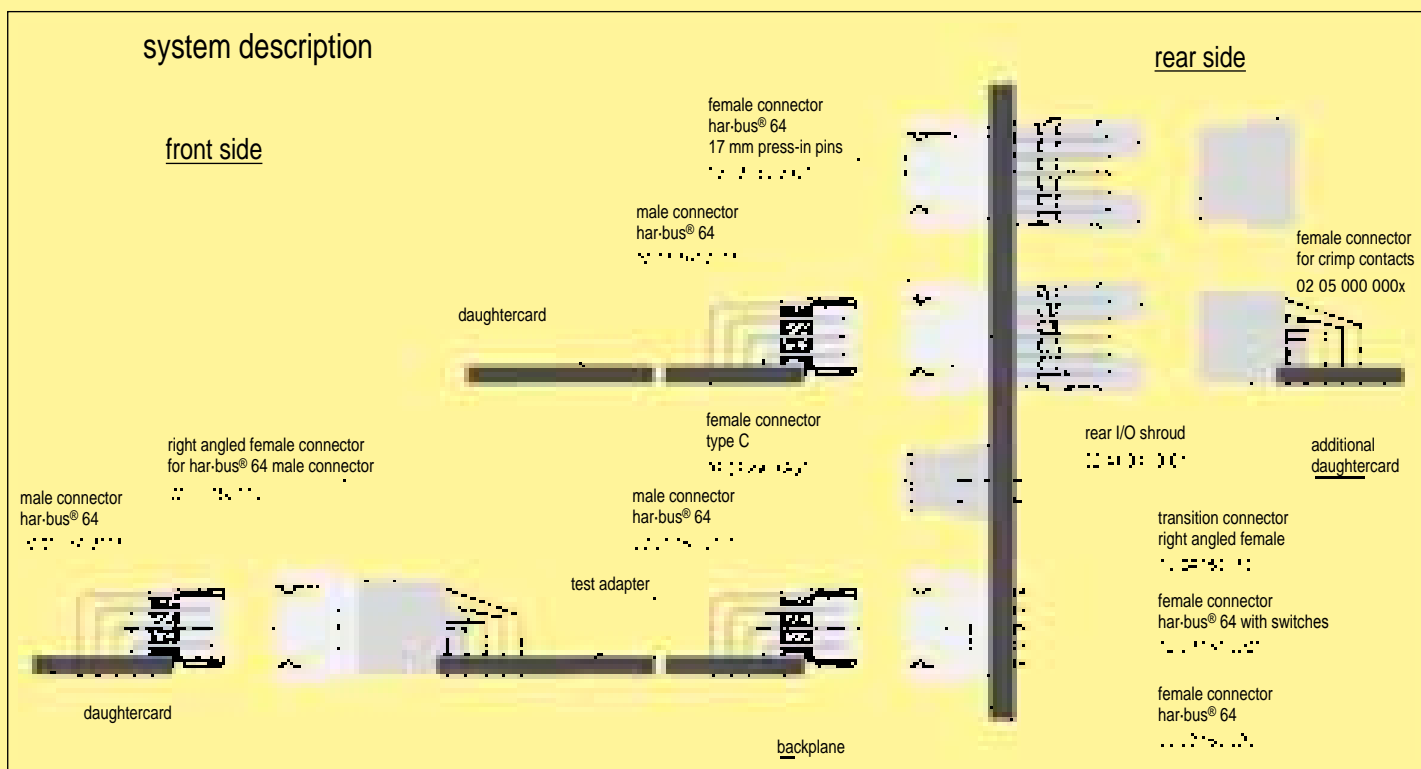

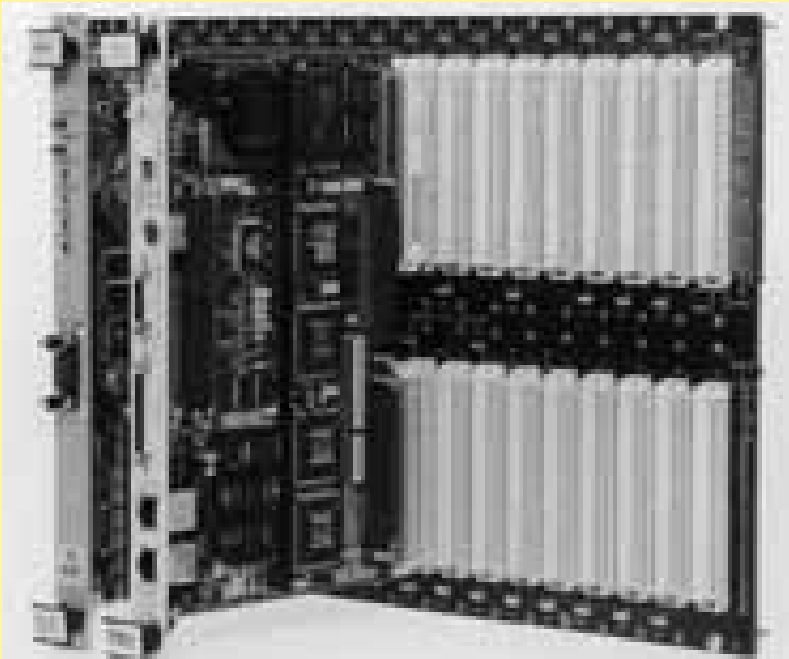

As a typical multiprocessor bus, VME has to distribute processor information continuously according to the right priorities.

This is done through the well known daisy-chain lines.

The VME protocol requests 5 daisy-chains on position 1 of every backplane.

These lines are defined to go through every daughter card.

Therefore, in case of unloaded card slots the signal have to be bridged across the connector.

Bridging variants:

1. The empty card slots may be assembled with dummy cards, that bridge the daisy-chain lines.
2. Bridging can be achieved by inserting 5 jumpers on the backplane manually.
3. Bridging by using IC's with internal integration OR the function may accept automatic daisy-chaining.
4. The new 5-row ~~haribus 64~~ connector with switches allows an automatic switching. In the case of an unmated daughter card the connector bridges the signals at positions a21-22, b4-5, b6-7, b8-9 and b10-11. The switch elements open automatically when the daughter card is mated, so that the daughter card accepts the ongoing signal daisy-chain.

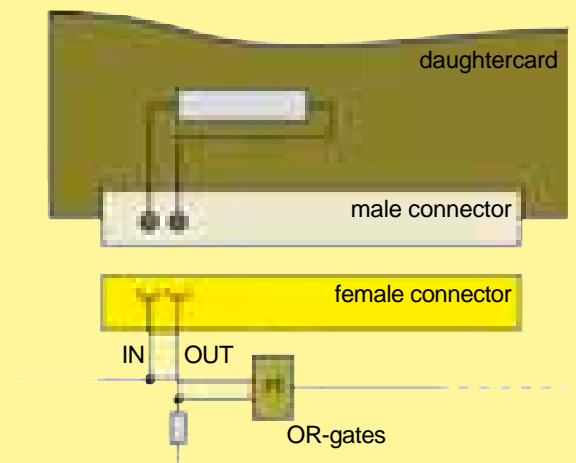
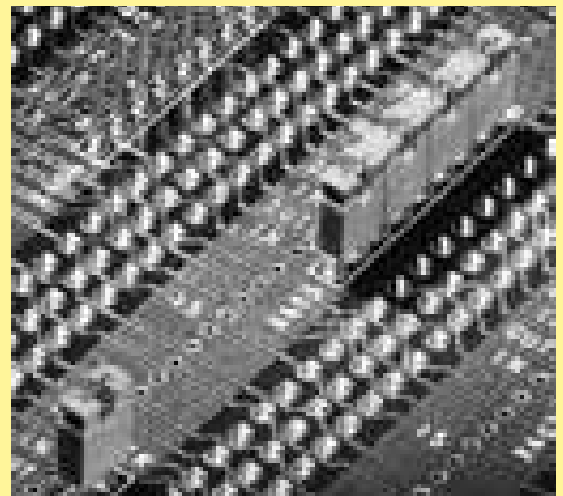

5-row ~~bus~~ **bus 64** connector
with switches

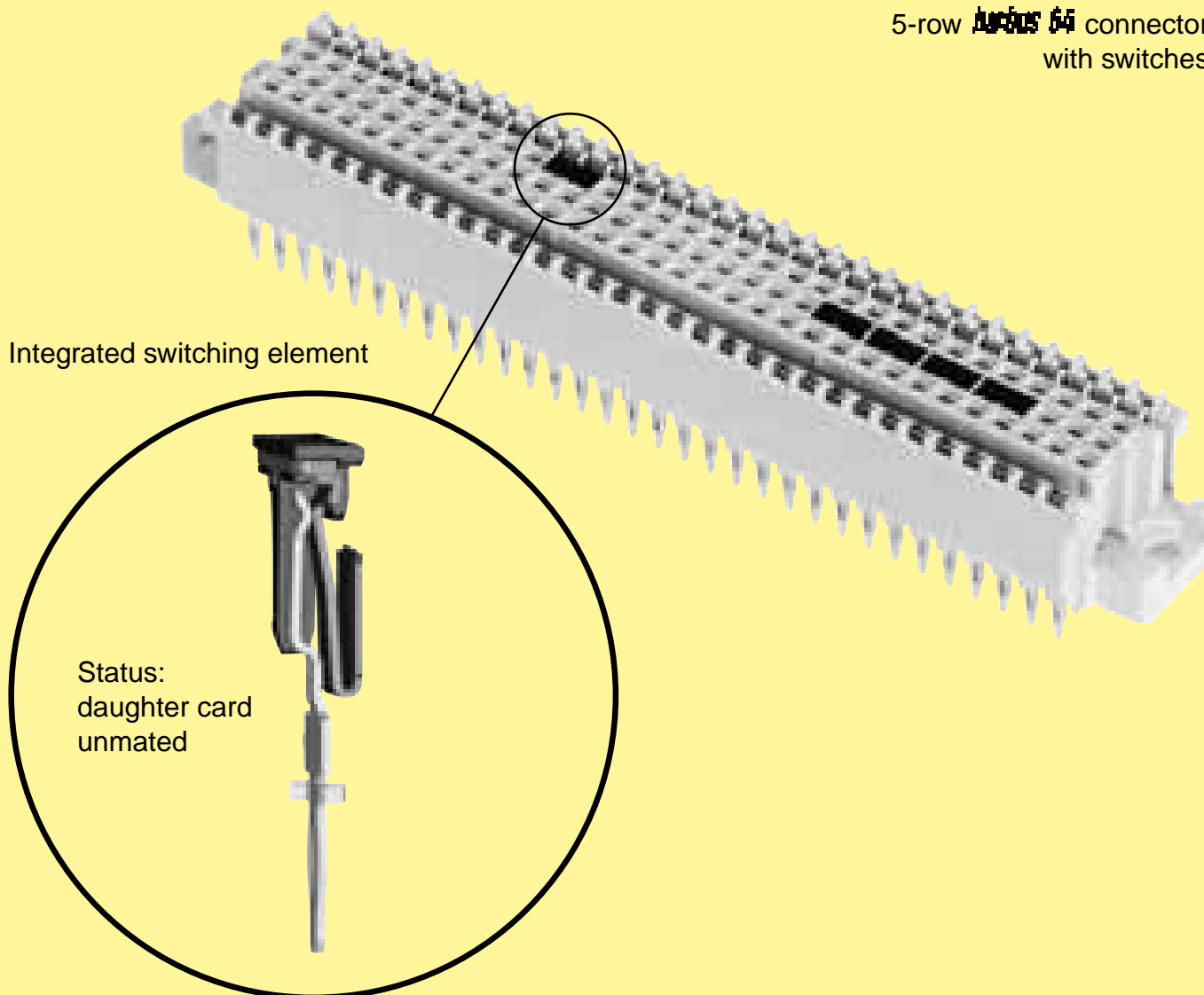

Integrated switching element

Status:
daughter card
unmated

Advantages:

- Passive backplane; no active components assembled
- No additional space required, due to integrated switching function inside the connector
- No jumpers on the backplane
- User friendly regarding maintenance and repairing
- Automatically daisy-chaining through mating/unmating the daughter card
- High MTBF value
- No additional, manual bridging necessary
- Less assembly cost, no special tooling required

MEMBER
VITA
Open Standards, Open Markets

VMEbus
Technology



har-bus 64

Number of contacts	160			
Contact spacing (mm)	2.54			
Working current	1 A at 70 °C and all contacts are loaded			
	see current carrying capacity chart			
Clearance and creepage distances				
minimal clearance and creepage distance		distance in mm		
		rows a, b, c	rows z, d	female angled
between two rows	clearance	1.2	1.2	0.6
	creepage	1.2	1.2	0.6
between two contacts (in a row)	clearance	1.2	1.0	0.8
	creepage	1.2	1.0	0.8
Working voltage				
The working voltage also depends on the clearance and creepage dimensions of the pcb itself and the associated wiring		according to the safety regulations of the equipment Explanations see chapter 00		
Test voltage $U_{r.m.s.}$	1 kV			
Contact resistance				
rows a, b, c	$\leq 20 \text{ m}\Omega$			
rows z, d	$\leq 30 \text{ m}\Omega$			
Insulation resistance	$\geq 10^{10} \Omega$ acc. to IEC 60512-2			
Temperature range				
for press-in termination	- 55 °C ... + 125 °C - 40 °C ... + 105 °C acc. to IEC 60512-11			
During reflow soldering	max. + 240 °C for 20 s for SMC connectors			
The higher temperature limit includes the local ambient and heating effects of the contacts under load				
Electrical termination				
		Solder pins for pcb termination $\varnothing 1.0 \pm 0.1 \text{ mm}$ according to IEC 60326-3 Crimp terminal 0.09 - 0.50 mm ² Compliant press-in terminations		
pcb thickness	$\geq 1.6 \text{ mm}$			
Recommended pcb holes for press-in technology	See recommendation page 00.25 in acc. to EN 60352-5			
Insertion and withdrawal force	$\leq 160 \text{ N}$			
Materials				
Mouldings	<ul style="list-style-type: none"> Liquid Cristal Polymer (LCP), for male connectors, straight female connectors, UL 94-V0 Thermoplastic resin glass-fibre filled, UL 94-V0 			
Contacts	Copper alloy			
Contact surface				
Contact zone	Plated acc. to performance level ¹⁾			

Current carrying capacity chart

The current carrying capacity is limited by maximum temperature of materials for inserts and contacts including terminals. The current capacity curve is valid for continuous, non interrupted current loaded contacts of connectors when simultaneous power on all contacts is given, without exceeding the maximum temperature.

Control and test procedures according to DIN IEC 60512

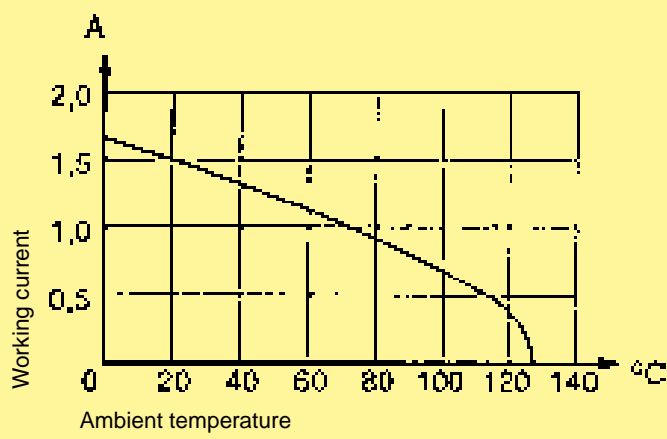

With selective loading higher currents can be transmitted. The requirements according to VITA 1.7 are fulfilled.

Aeribus 64 with switches

Deviating technical characteristics for the switching elements.

minimal clearance and creepage distance	distance in mm	
	switching positions	
between two rows	clearance	0.5
	creepage	0.7
between two contacts (in a row)	clearance	0.5
	creepage	0.7

Contact resistance
Switching elements $\leq 60 \text{ m}\Omega$

Insertion and withdrawal force
Complete connector $\leq 180 \text{ N}$

¹⁾ Explanation performance levels see chapter 00

Number of contacts

160

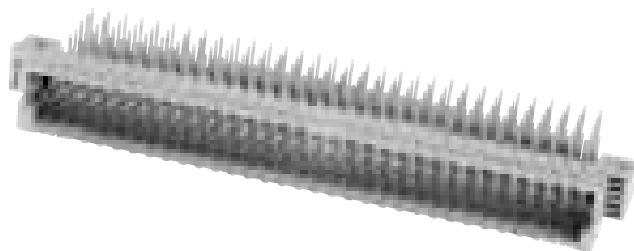

Male connectors, angled, SMC compatible

Identification	Number of contacts	Contact arrangement	Part No.	Performance levels according to IEC 61 076-4-113	
			2	Explanation chapter 00	
Male connector* without retention clip	160	z, a, b, c, d	02 01 160 2101	02 01 160 1101	02 01 160 1105 ²⁾
	160	z, a, b, c, d	02 01 160 2102	02 01 160 1102	02 01 160 1106 ²⁾
Dimensions					
Board drillings Mounting side					
Cross section of solder terminations	Row z: A = 0.21 - 0.25 mm ²	Rows a, b, c: A = 0.25 - 0.33 mm ²	Row d: A = 0.29 - 0.32 mm ²		
				<p>A = cross area of contacts</p> <p>Dimensions in mm</p>	

har-bus 64

* Pre-leading contacts at positions d1, d2, d31 and d32

¹⁾ Recommendation for variants with clip: Drillings can be enlarged up to 3.1 mm \varnothing to reduce standard mounting force (see chapter 00)

²⁾ Special variant with min. 1.27 μ m (50 μ inch) Au and SnPb on termination

Number of contacts

160

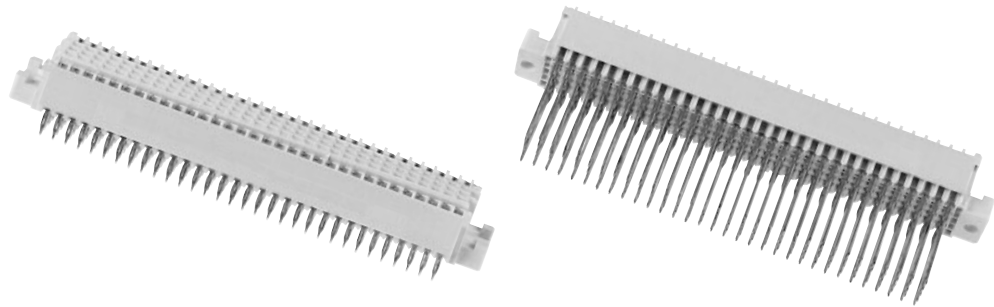

Female connectors

Identification	Number of contacts	Contact arrangement	Part No. Performance levels according to IEC 61 076-4-113	
			2	1
Female connectors, straight ²⁾				
with press-in terminations				
with fixing flange	3.7 mm	z, a, b, c, d		02 02 160 1601
	4.5/5 mm	z, a, b, c, d	02 02 160 2201	02 02 160 1201
	17 mm*	z, a, b, c, d	02 02 160 2301	02 02 160 1301
without fixing flange	5 mm	z, a, b, c, d	02 02 160 2202	02 02 160 1202
	17 mm*	z, a, b, c, d	02 02 160 2302	02 02 160 1302

Dimensions

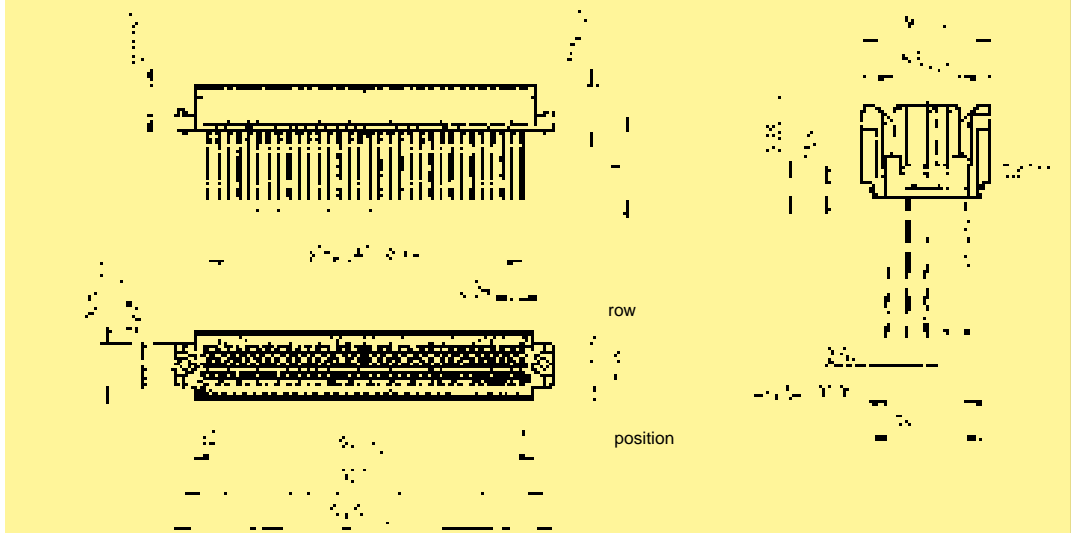

Part number	Dimension "X" for row				
	z	a	b	c	d
02 02 160 1601	3.7	3.7	3.7	3.7	3.7
02 02 160 2201 / 02 02 160 1201	5.0	4.5	4.5	4.5	5.0
02 02 160 2301 / 02 02 160 1301	17.0	17.0	17.0	17.0	17.0
02 02 160 2202 / 02 02 160 1202	5.0	5.0	5.0	5.0	5.0
02 02 160 2302 / 02 02 160 1302	17.0	17.0	17.0	17.0	17.0

Board drillings

Mounting side

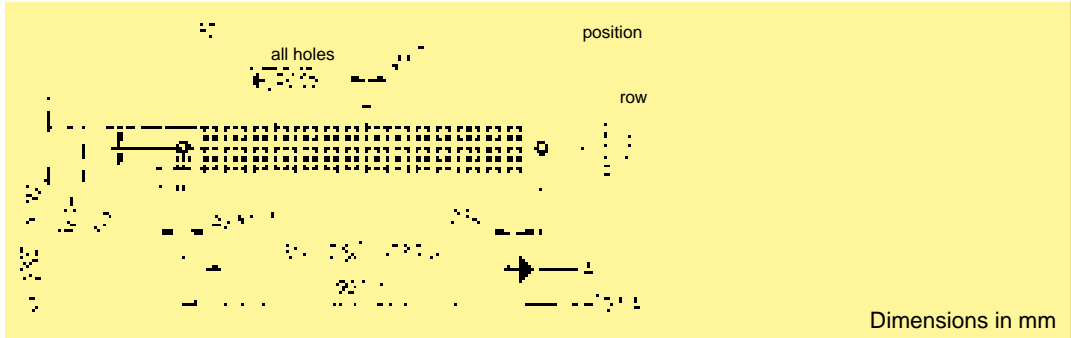

Dimensions in mm

har-bus 64

02
12

Tooling see chapter 30

¹⁾ Press-in technology and refer to recommended configuration of pcb holes, see page 00.25

* selectively gold-plated

Number of contacts

160

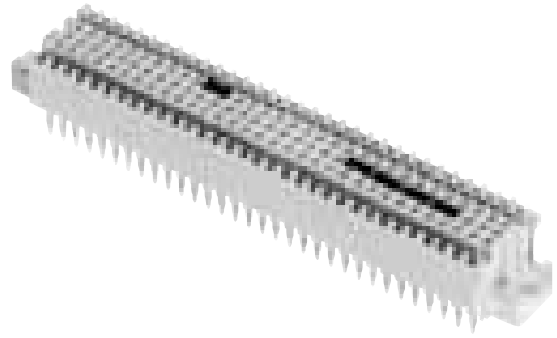

Female connectors

Identification	Number of contacts	Contact arrangement	Part No. Performance level 2 according to IEC 61 076-4-113 Explanation chapter 00
Female connectors, straight with switches ²⁾ with press-in terminations with flange 4.5/5 mm	160	z, a, b, c, d	02 03 160 2201

Dimensions

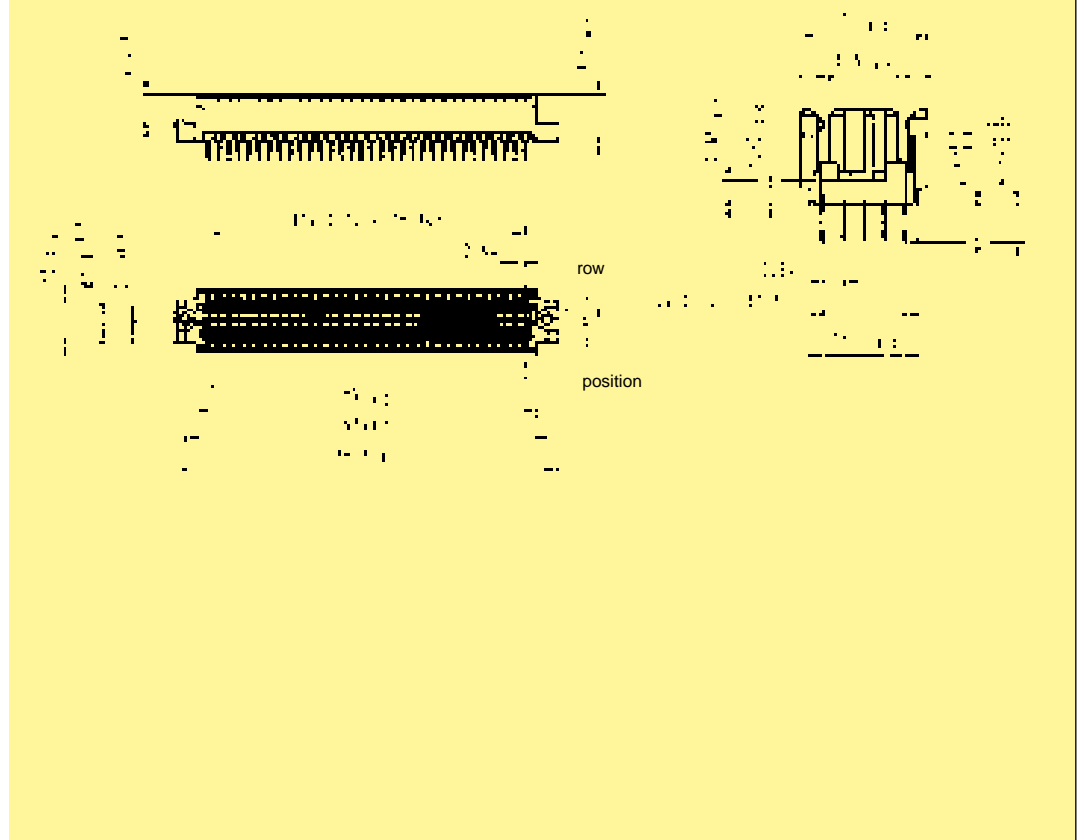

Board drillings

Mounting side

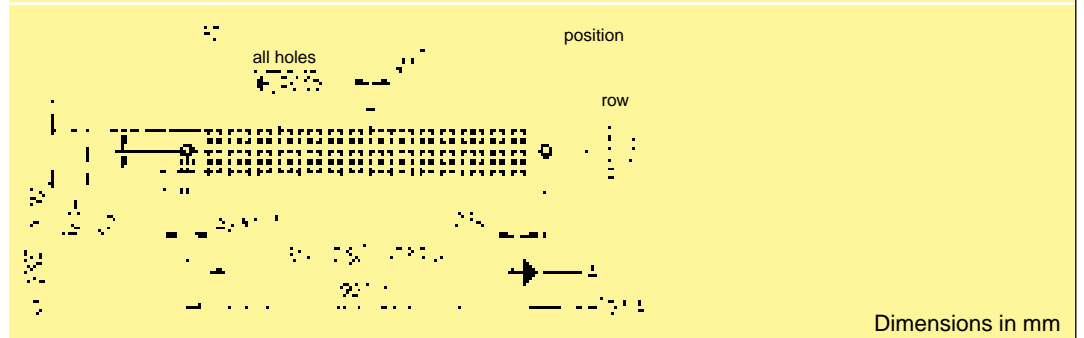

Dimensions in mm

har-bus 64

02
13

Tooling see chapter 30

¹⁾ Press-in technology see page 00.25

²⁾ Switching elements at positions a21-22, b4-5, b6-7, b8-9 and b10-11

Number of contacts

160

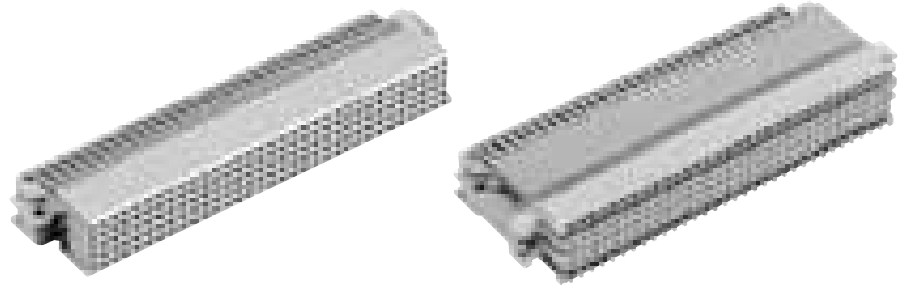

Female connectors

Identification	Number of contacts	Contact arrangement	Part No. Performance level 1 according to IEC 61076-4-113 Explanation chapter 00
Female connectors, angled with solder pins			
for rear access	160	z, a, b, c, d	02 04 160 1101
for har-bus® 64 male connector	160	z, a, b, c, d	02 07 160 1101

Dimensions
02 04 160 1101

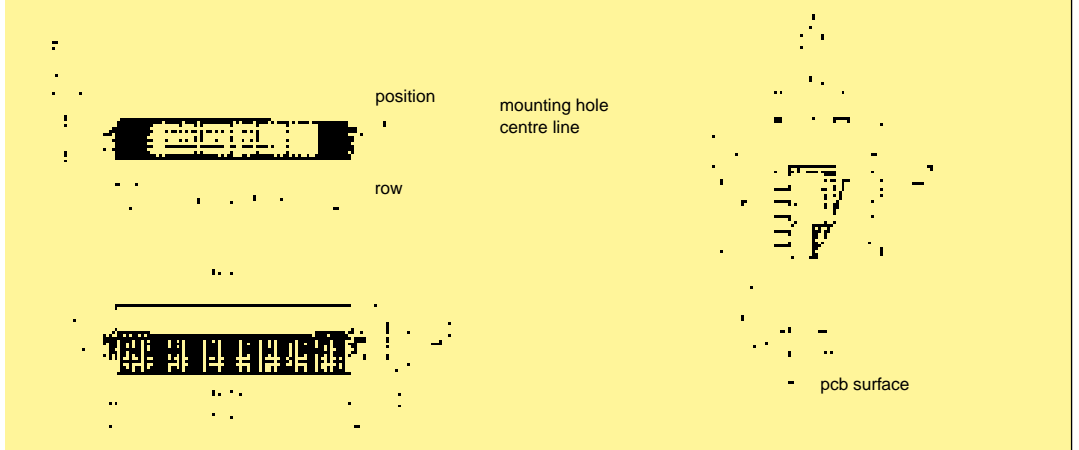

Dimensions
02 07 160 1101

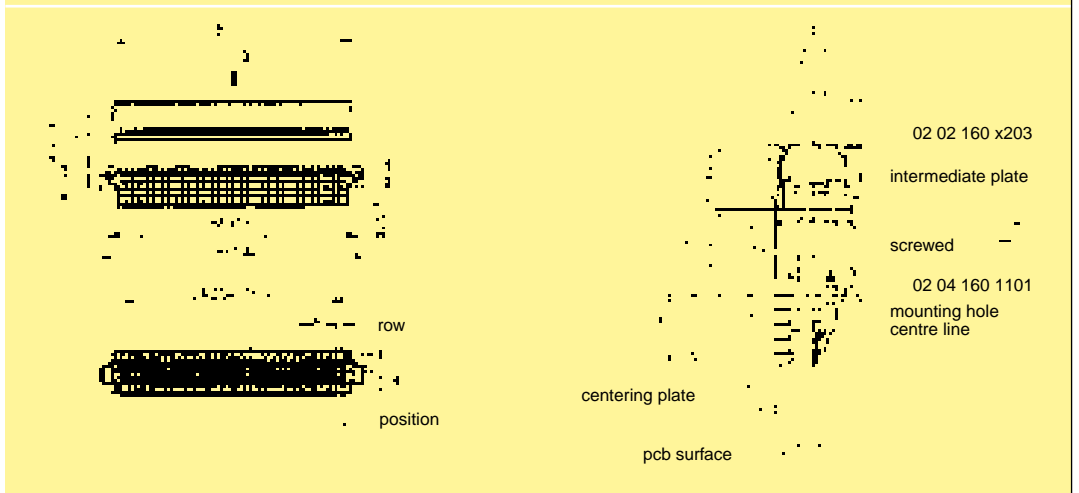

Board drillings
Mounting side

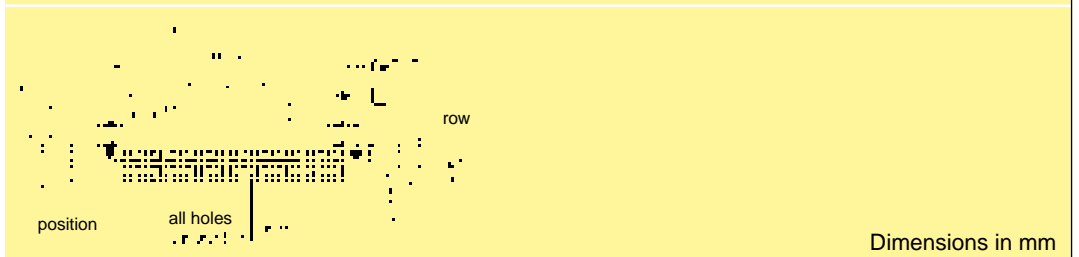

Dimensions in mm

Number of contacts

max. 160

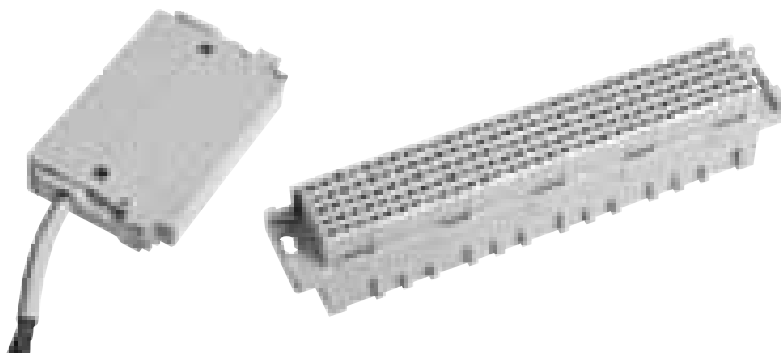

Female connectors

Identification	Number of contacts	Contact-arrangement	Suitable for	Part No.
Female connector for crimp contacts order contacts separately fits into shell housing C see chapter 20	160		har-bus® 64 shroud	02 05 000 0004
	160		Male connector type R with 5 rows	02 05 000 0005
	160		Male connector type C with 5 rows	02 05 000 0003

Dimensions	Dimensions	

Identification	Part No.	Performance levels according to IEC 61076-4-113. Explanation chapter 00
		2 1
Female crimp contacts har-bus® 64 Bandoliered contacts (approx. 5,000 pieces) Bandoliered contacts (approx. 500 pieces) Individual contacts ¹⁾	02 05 000 2511	02 05 000 1511
	02 05 000 2512	02 05 000 1512
	02 05 000 2513	02 05 000 1513

Wire gauge	AWG	Insulation ø	
mm ²		mm	
0.09 - 0.5	28 - 20	0.7 - 1.5	
3.5 + 0.5 mm of insulation is stripped For the fabrication in line with the specification please use exclusively crimp tools approved by HARTING (see DIN EN 60352-2) Insertion, removal and crimping tools see chapter 30			
			Bandoliered contacts Individual contacts

¹⁾ Packaging unit 1,000 pieces



Number of contacts

160

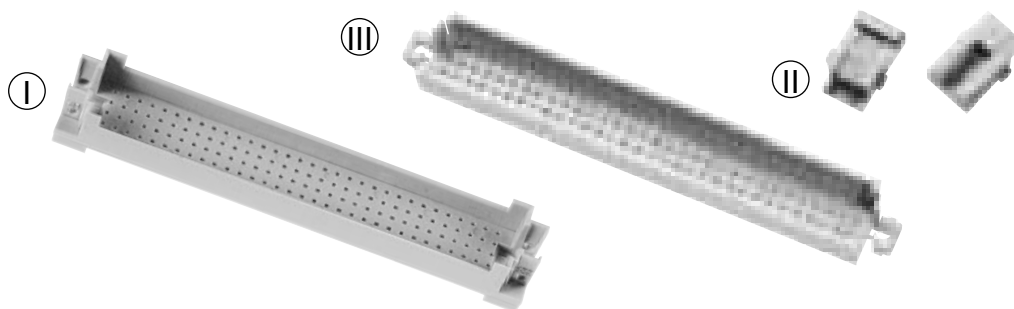

Pin shrouds

Identification	pcb-thickness ± 0.3	Dimension X - 0.1	Part No.
Pin shrouds ¹⁾			
I	2.8	6.6	02 44 000 0007
	3.4	6.0	02 44 000 0001
	4.0	5.4	02 44 000 0002
	4.6	4.8	02 44 000 0003
	5.2	4.2	02 44 000 0004
	5.8	3.6	02 44 000 0005
	6.4	3.0	02 44 000 0006
II Fixing brackets for shell housing C ²⁾			02 44 000 0009
III Shroud insert for 3 row female connectors			02 44 000 0008

Dimensions

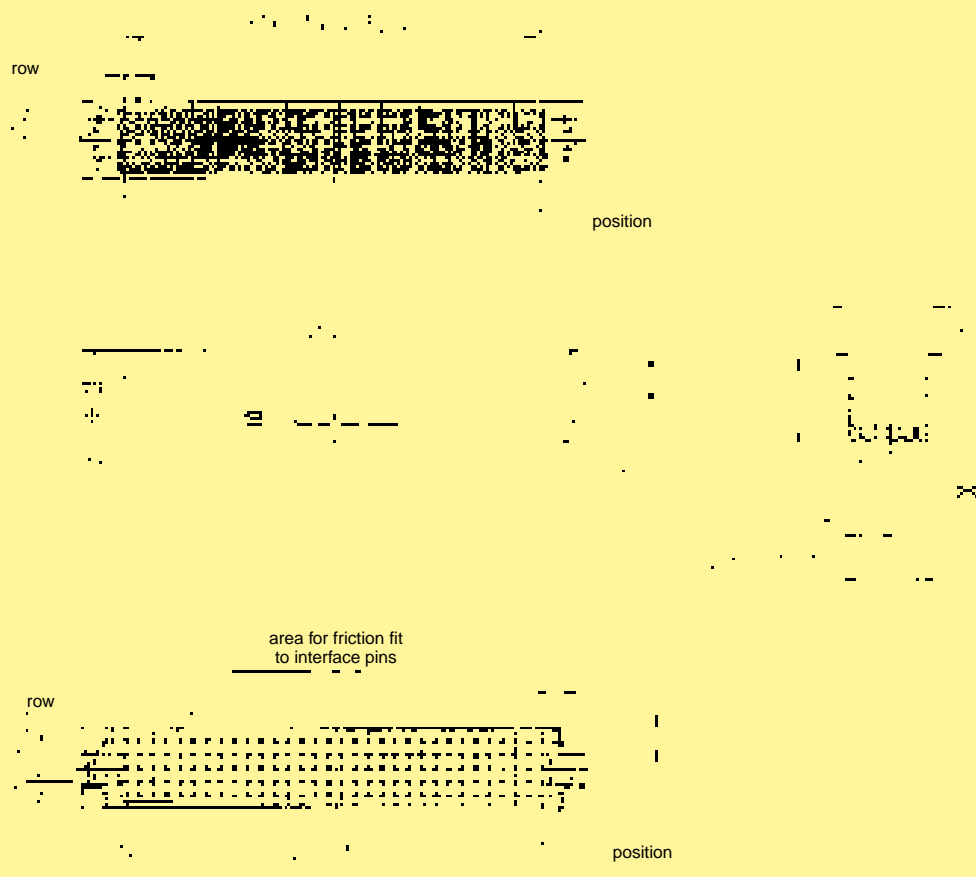

Dimensions in mm

har-bus 64

¹⁾ Insert block (02 09 000 0012) for assembly see chapter 30

²⁾ order 2 pieces per connector

Application 1*

Female connector
02 02 160 2301



Backplane



Pin shroud
02 44 000 0007



Fixing brackets
02 44 000 0009



Shell housing C
09 05 048 0501

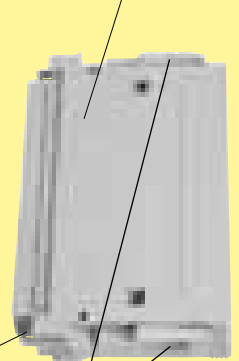

Female connector
with crimp contacts
02 05 000 0004

Locking lever
left 09 02 000 9902
right 09 02 000 9903

har-bus 64

Application 2*

Female connector
02 02 160 2301



Backplane



Pin shroud
02 44 000 0007



Locking lever
09 03 000 9913



Female connector
for crimp contacts
02 05 000 0004



Application 3

Female connector
02 02 160 2301



Backplane



Pin shroud
02 44 000 0007



Shroud insert
02 44 000 0008



Female connector
09 73 296 6801

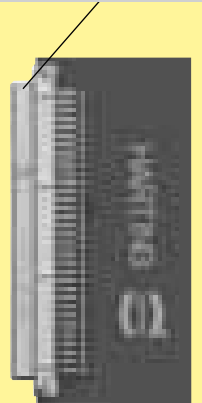

* Only for applications without rear P0-connector

Application 4

Female connector
02 02 160 2301



Backplane



Pin shroud
02 44 000 0007



Screw
M 2.5 x 30



Female connector
for crimp contacts
02 05 000 0004





Types D, E, F, FM, 2F, F9, interface connectors I/U

Page

Technical characteristics types D and E **03.10**

Type D connectors **03.11**

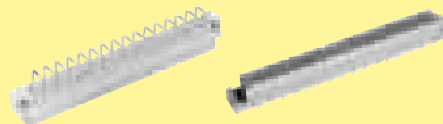

Type E connectors **03.15**



Pin shrouds **03.19**

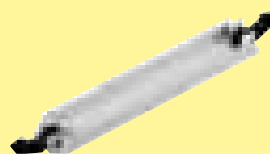

Application examples types E and F **03.20**

Technical characteristics piggyback connectors **03.22**

Piggyback connectors **03.23**

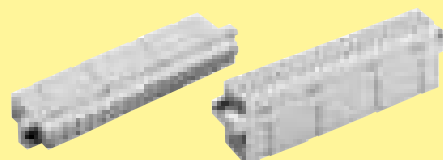

Technical characteristics types F, F9, FM and 2F **03.26**

Type F connectors **03.27**

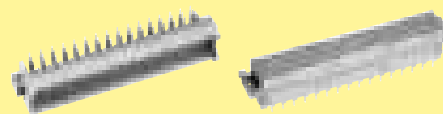

Type F9 connectors **03.37**



Type FM connectors **03.38**

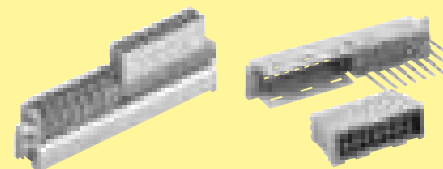

Type 2F connectors **03.40**

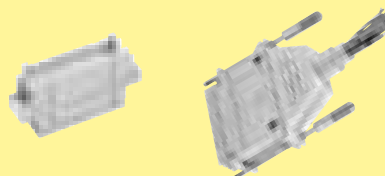

DIN Power
up to 6 A



Number of contacts	
Type D	32
Type E	48
Contact spacing (mm)	
Type D	5,08
Type E	male connector 5.08 x 5.08 male connector 2.54 x 5.08 female connector 5.08 x 5.08
Working current	6 A max. see current carrying capacity chart
Clearance	
Types D and E	≥ 3.0 mm
Type E male connector	≥ 1.6 mm
row separation	2.54 mm
Creepage	≥ 3.0 mm
Working voltage	
The working voltage also depends on the clearance and creepage dimensions of the pcb itself and the associated wiring	according to the safety regulations of the equipment Explanations see chapter 00
Test voltage $U_{r.m.s.}$	1.55 kV
Contact resistance	≤ 15 mΩ
Insulation resistance	≥ 10 ¹² Ω for standard articles ≥ 10 ¹¹ Ω for special NFF articles (with part-no. ending 222)
Temperature range	
The higher temperature limit includes the local ambient and heating effects of the contacts under load	- 55 °C ... + 125 °C - 40 °C ... + 105 °C for press-in connectors
Degree of protection for crimp terminal according to DIN 40 050	IP 20
Electrical termination	
	Solder pins for pcb connections Ø 1.0 ± 0.1 mm according to IEC 60 326-3 Wrap posts 1 x 1 mm diagonal 1.34-1.45 mm Angled solder pins 1 x 1 mm for pcb connections Ø 1.6 ± 0.1 mm Solder lugs Crimp terminal 0.09-1.5 mm ² Compliant press-in terminations
PCB thickness	≥ 1.6 mm
Recommended PCB holes for press-in technology	see recommendation page 00.25 in acc. to EN 60 352-5
Insertion and withdrawal force	
32 way	≤ 40 N
48 way	≤ 75 N
Materials	
Mouldings	Thermoplastic resin, glass-fibre filled, UL 94-V0
Contacts	Copper alloy
Contact surface	
Contact zone	Selectively gold plated according to performance level ¹⁾
¹⁾ Explanation of performance levels see chapter 00	

Current carrying capacity

The current carrying capacity is limited by maximum temperature of materials for inserts and contacts including terminals. The current capacity curve is valid for continuous, non interrupted current loaded contacts of connectors when simultaneous power on all contacts is given, without exceeding the maximum temperature.

Control and test procedures according to DIN IEC 60 512

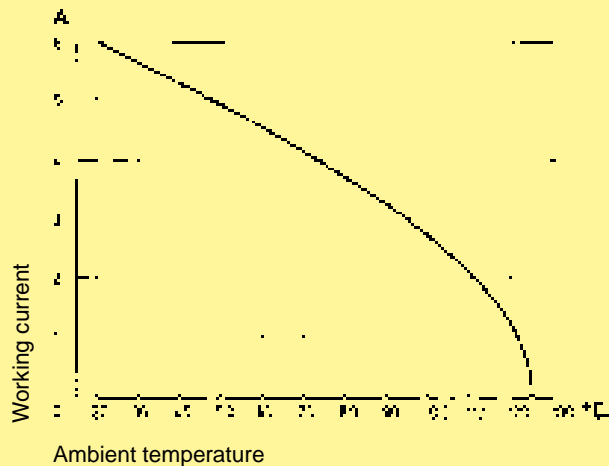

Fitting the crimp contacts

After crimping the wires onto the contacts with the help of a crimping tool or an automatic crimping machine the contacts should be correctly oriented and inserted into the cavities of the connector moulding in the required configuration. They snap into position and are firmly held in place. A light pull on the wire assures the correct tensile strength of the contact. When using stranded wires with a gauge below 0.37 mm² an insertion tool is necessary.

Removing the crimp contacts

The removal tool is inserted into a slot on the side of the respective crimp cavity. This action compresses the contact retaining spring therefore the contact can then be easily withdrawn using a light pull on the wire. This action will cause no damage to the contact/wire which can be repositioned/refitted as necessary. The drawing demonstrates the crimp removal procedure (max. 5x).

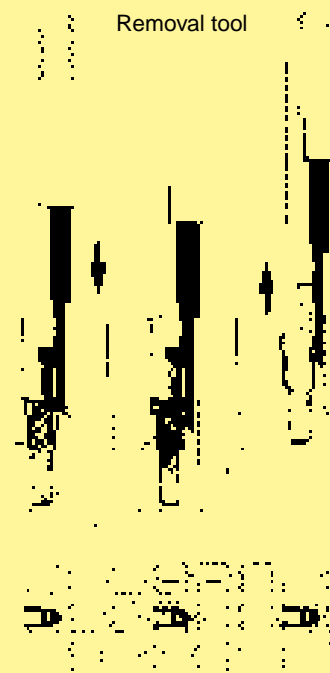

DIN Power up to 6 A

Number of contacts

32

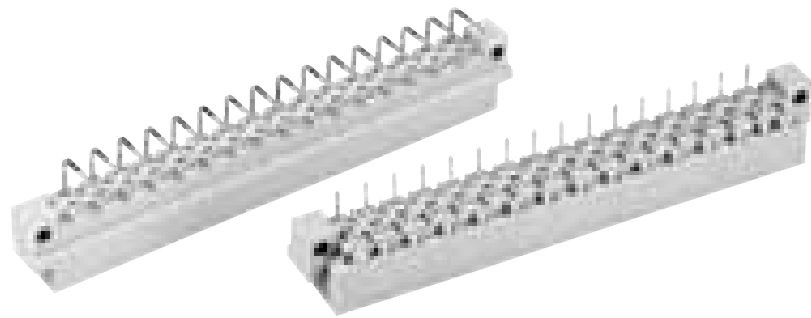

Male connectors

Identification	Number of contacts	Contact arrangement	Part No.	Performance levels according to IEC 60603-2. Explanation chapter 00		
				3	2	1
Male connector with angled solder pins SMC	32		09 04 132 7921	09 04 132 6921 09 04 132 6921 222 ^{f)} 09 04 332 6921 ^{b)} 09 04 632 6921 ^{c)}	09 04 132 2921 09 04 132 2921 222 ^{f)}	
	32			09 04 332 6919 ^{b)d)}		
	30 + 2 [▲]			09 04 132 6951 09 04 632 6951 ^{c)}	09 04 632 2951 ^{c)}	
Male connector with straight solder pins	32			09 04 132 6922		
	30 + 2 [▲]			09 04 132 6952		

DIN Power up to 6 A

Dimensions



Board drillings

Mounting side

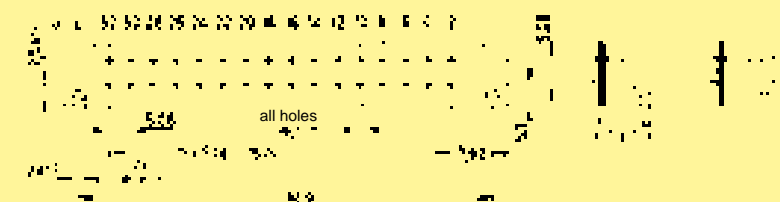

Dimensions in mm

▲ Male connectors with 2 leading contacts [(0.8 mm) pos. a2 and a32]
Other contact arrangements on request
b) Connectors with snap-in clips see chapter 00
c) Connectors with coding see chapter 00

d) CTI > 400
f) Railway classification NFF 16-101, Smoke index: F1, Flammability class: I2

Number of contacts

32

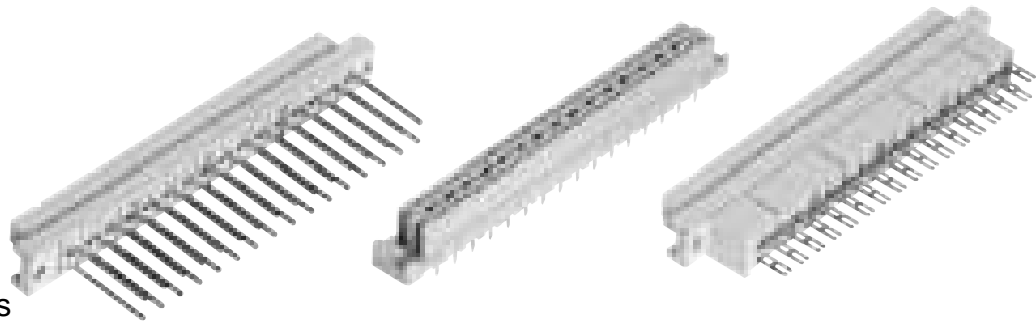

Female connectors

DIN Power
up to 6 A

Identification	Number of contacts	Contact arrangement	Part No.	Performance levels according to IEC 60603-2. Explanation chapter 00		
				3	2	1
Female connector with solder pins 2.9 mm	32		09 04 232 7832	09 04 232 6832 09 04 732 6832 ^{c)}	09 04 232 2832	
Female connector with solder pins 4.5 mm	32		09 04 232 7831	09 04 232 6831 09 04 232 6831 222 ^{f)} 09 04 332 6831 ^{b)} 09 04 732 6831 ^{c)}	09 04 232 2831 09 04 232 2831 222 ^{f)}	
Female connector with wrap posts 20 mm	32		09 04 232 7821	09 04 232 6821 09 04 732 6821 ^{c)}	09 04 232 2821	
Female connector with solder lugs	32		09 04 232 7823	09 04 232 6823	09 04 232 2823	

Dimensions

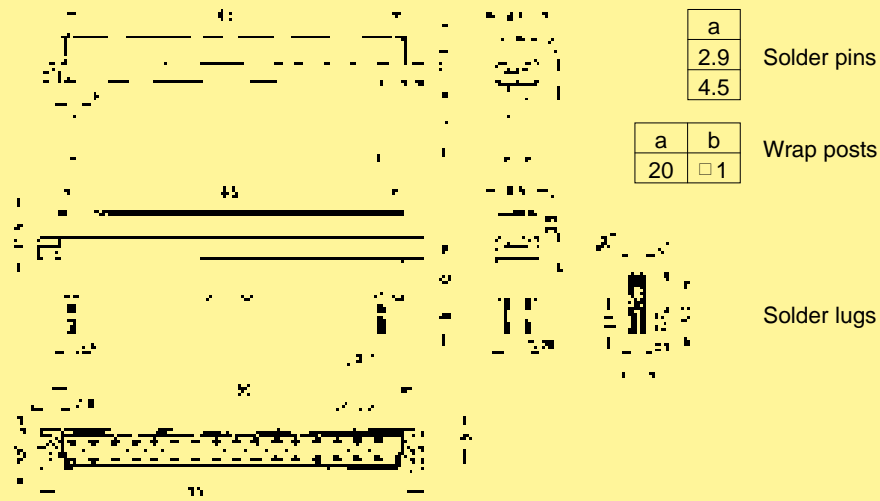

Panel cut out



Board drillings
Mounting side

Dimensions in mm

^{b)} Connectors with snap-in clips see chapter 00
^{c)} Connectors with coding see chapter 00

^{f)} Railway classification NFF 16-101, Smoke index: F1, Flammability class: I2

Number of contacts

32

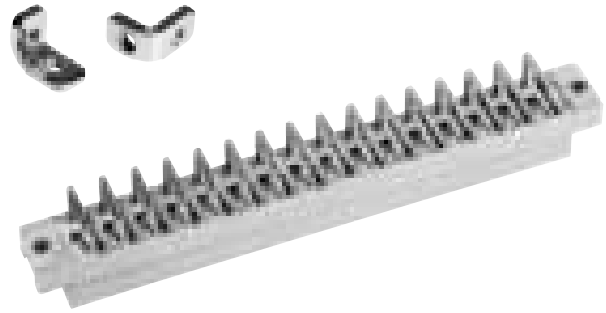

Female connectors

Identification	Number of contacts	Contact arrangement	Part No.	Performance levels according to IEC 60603-2. Explanation chapter 00	
				2	1
Female connector with angled solder pins 1 x 1 mm	32			09 04 232 6826 09 04 232 6826 222 ^{f)}	09 04 232 2826
Dimensions					
Fixing bracket Metal			09 06 000 9912 ¹⁾		
Board drillings Mounting side					

DIN Power up to 6 A

03
13

Dimensions in mm

^{f)} Railway classification NFF 16-101, Smoke index: F1, Flammability class: I2

Number of contacts

max. 32



Female connectors

Identification	Number of contacts	Part No.	Drawing	Dimensions in mm
Female connector for crimp contacts Order contacts separately	32	09 04 032 3213 ^{f)}		
	32	09 04 532 3213 ^{c)f)}		
Shell housing 09 03 096 0501 see chapter 20				

Identification	Identification Wire gauge	Part No.	Performance levels according to IEC 60603-2. Explanation chapter 00
		2	1
Female crimp FC contacts			
Bandoliered contacts (approx. 2,500 pieces)	1	09 06 000 6484	09 06 000 6474
	2	09 06 000 6481	09 06 000 6471
	3	09 06 000 6482	09 06 000 6472
Bandoliered contacts (approx. 250 pieces)	1	09 06 000 7484	09 06 000 7474
	2	09 06 000 7481	09 06 000 7471
	3	09 06 000 7482	09 06 000 7472
Individual contacts ¹⁾	1	09 06 000 8484	09 06 000 8474
	2	09 06 000 8481	09 06 000 8471
	3	09 06 000 8482	09 06 000 8472
Female contacts with solder lugs ²⁾ (lockable)			09 06 000 6420

	FC 1	FC 2	FC 3	Wire gauge mm ²	AWG	Insulation ø mm	Identification
				0.09 - 0.25	28 - 24	0.7 - 1.5	
				0.14 - 0.56	26 - 20	0.8 - 2.0	
				0.5 - 1.5	20 - 16	1.6 - 2.8	
				3.5 + 0.5 mm of insulation is stripped from the wires to be crimped			Bandoliered contacts
				For the fabrication in line with the specification please use exclusively crimp tools approved by HARTING (see DIN EN 60352-2)			Individual contacts
				Insertion, removal and crimping tools see chapter 30			

¹⁾ Packaging unit 1,000 pieces

²⁾ Solder contacts must not be used together with shell housing A. Special contact surface: 2 µm gold.

^{c)} Connectors with coding see chapter 00

^{f)} Railway classification NFF 16-101, Smoke index: F1, Flammability class: I2

Number of contacts

48

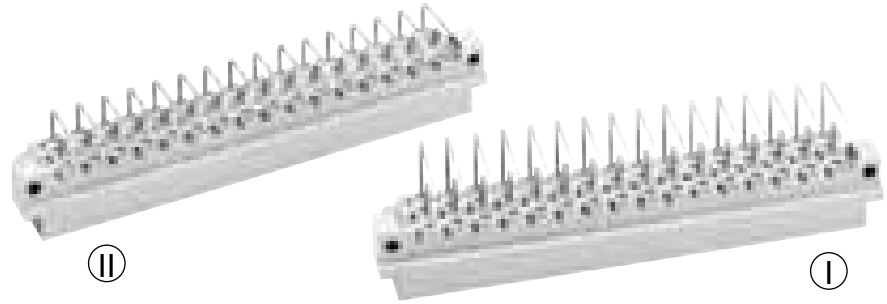

Male connectors

Identification	Number of contacts	Contact arrangement	Part No.	Performance levels according to IEC 60603-2. Explanation chapter 00		
				3	2	1
Male connector with angled solder pins Row separation termination side 5.08 mm (I) Row separation termination side 2.54 mm (II) SMC	48		09 05 148 7921	09 05 148 6921 09 05 148 6921 222 ^{f)} 09 05 348 6921 ^{b)} 09 05 648 6921 ^{c)}	09 05 148 2921 09 05 148 2921 222 ^{f)} 09 05 648 2921 ^{c)}	
	46 + 2 [▲]			09 05 148 6951		
	48		09 05 148 7931	09 05 148 6931 09 05 648 6931 ^{c)}	09 05 148 2931	
	48			09 05 148 6920 ^{d)}		
	46 + 2 [▲]			09 05 148 6961		

DIN Power up to 6 A

Dimensions

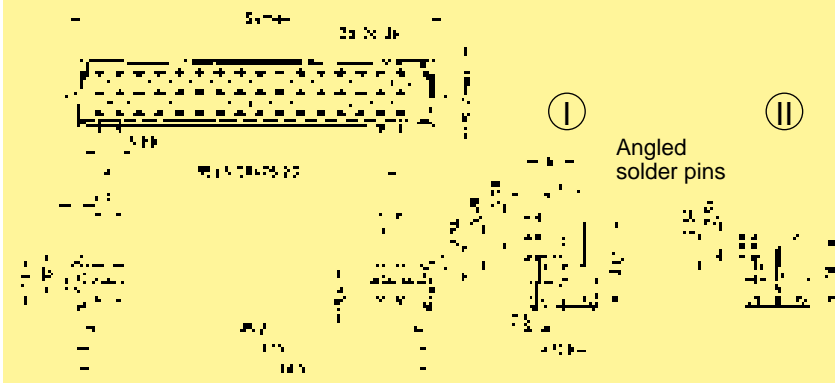

Board drillings

Mounting side

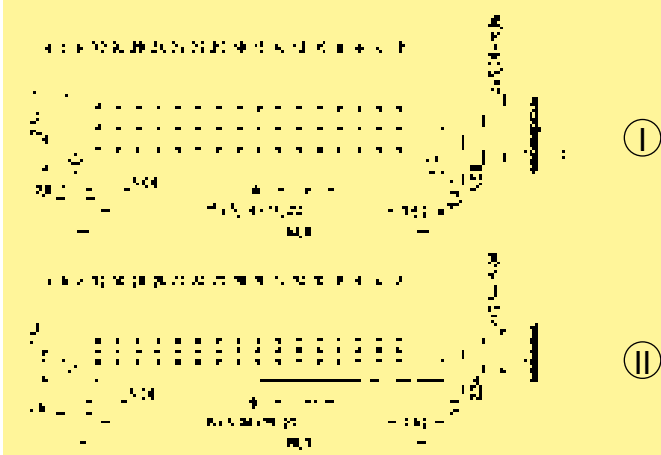

Dimensions in mm

▲ Male connectors with 2 leading contacts [(0.8 mm) pos. a2 and a32]
 Other contact arrangements on request
^{b)} Connectors with snap-in clips see chapter 00
^{c)} Connectors with coding see chapter 00

^{d)} CTI > 400
^{f)} Railway classification NFF 16-101, Smoke index: F1, Flammability class: I2



Number of contacts

48

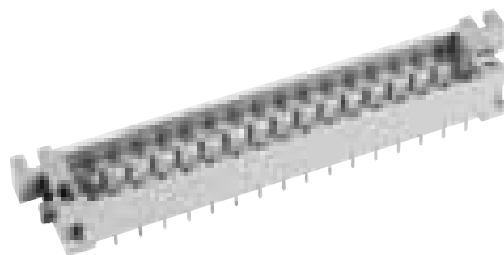

Interface connector I

DIN Power
up to 6 A

Identification	Number of contacts	Part No.	Drawing	Dimensions in mm
----------------	--------------------	----------	---------	------------------

Interface connector I
with solder pins
0.6 x 0.6 mm

48

Performance level 2
acc. to IEC 60 603-2

09 05 048 6924¹⁾

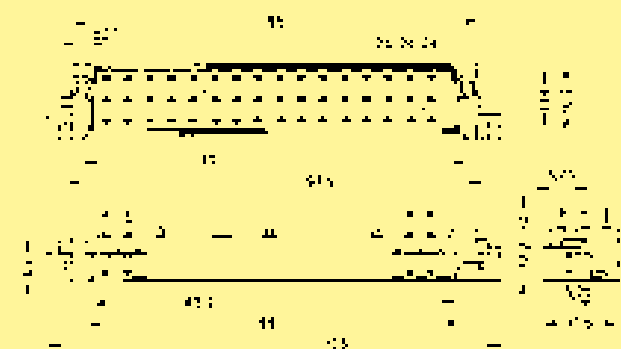

Contact arrangement View from termination side

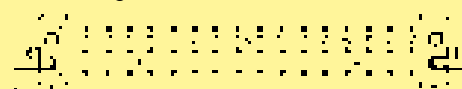

Panel cut out

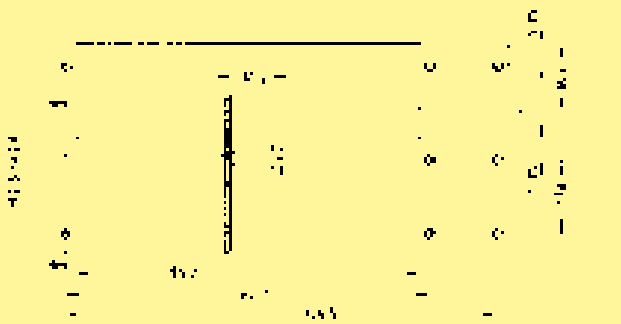

Board drillings
Mounting side

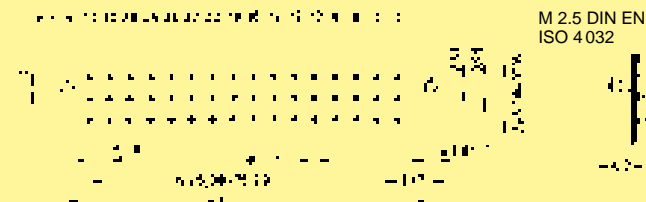

¹⁾ Railway classification NFF 16-101, Smoke index: F1, Flammability class: I2

Number of contacts

max. 48

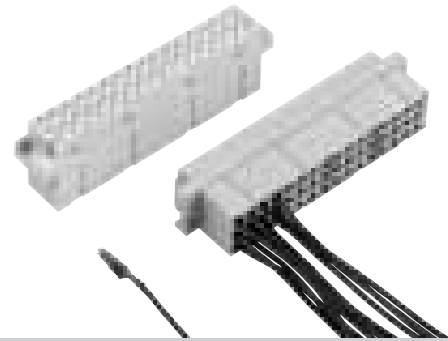

Female connectors

Identification	Number of contacts	Part No.	Drawing	Dimensions in mm
----------------	--------------------	----------	---------	------------------

Female connector for crimp contacts
Order contacts separately

48

09 05 048 3202¹⁾
09 05 548 3202²⁾

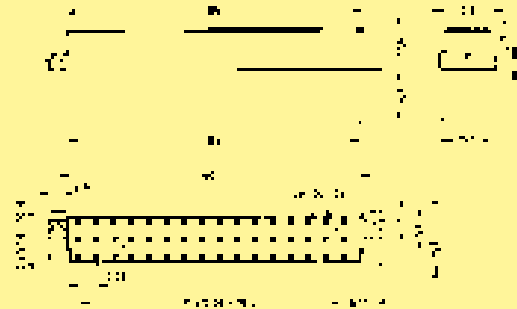

Contact arrangement View from termination side

Shell housing 09 05 048 0501 see chapter 20

DIN Power
up to 6 A

Identification	Identification Wire gauge	Part No.	Performance levels according to IEC 60603-2. Explanation chapter 00
----------------	---------------------------	----------	---

Female crimp FC contacts

Bandoliered contacts (approx. 2,500 pieces)

1
2
3

09 06 000 6484
09 06 000 6481
09 06 000 6482

09 06 000 6474
09 06 000 6471
09 06 000 6472

Bandoliered contacts (approx. 250 pieces)

1
2
3

09 06 000 7484
09 06 000 7481
09 06 000 7482

09 06 000 7474
09 06 000 7471
09 06 000 7472

Individual contacts¹⁾

1
2
3

09 06 000 8484
09 06 000 8481
09 06 000 8482

09 06 000 8474
09 06 000 8471
09 06 000 8472

Female contacts with solder lugs²⁾ (lockable)

09 06 000 6420

FC 1
FC 2
FC 3

1
2
3

Wire gauge mm ²	AWG	Insulation ø mm
0.09 - 0.25	28 - 24	0.7 - 1.5
0.14 - 0.56	26 - 20	0.8 - 2.0
0.5 - 1.5	20 - 16	1.6 - 2.8

3.5 + 0.5 mm of insulation is stripped from the wires to be crimped
For the fabrication in line with the specification please use exclusively crimp tools approved by HARTING (see DIN EN 60352-2)
Insertion, removal and crimping tools see chapter 30

Identification

Bandoliered contacts

Individual contacts

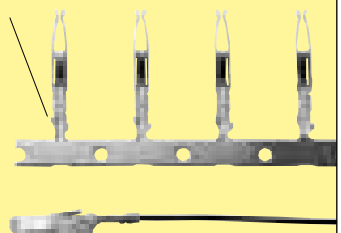

^{c)} Connectors with coding see chapter 00
¹⁾ Railway classification NFF 16-101, Smoke index: F1, Flammability class: I2

¹⁾ Packaging unit 1,000 pieces
²⁾ Solder contacts must not be used together with shell housing A. Special contact surface: 2 µm gold.



Number of contacts

48

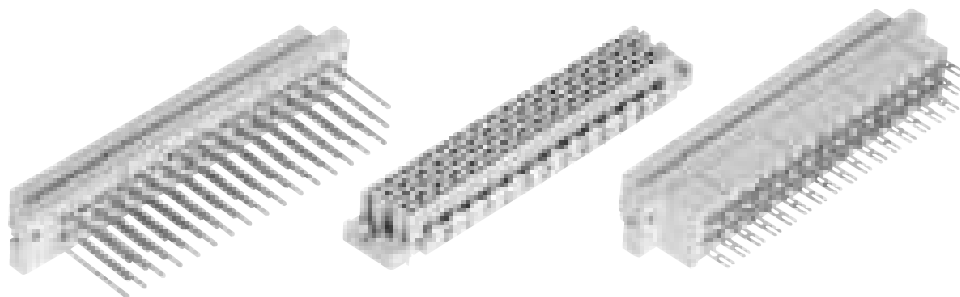

Female connectors

DIN Power up to 6 A

Identification	Number of contacts	Contact arrangement	Part No.	Performance levels according to IEC 60603-2. Explanation chapter 00	3	2	1
Female connector with solder pins 2,9 mm 4,5 mm	48		09 05 248 7832		09 05 248 6832	09 05 248 6831 09 05 348 6831 ^{b)} 09 05 748 6831 ^{c)}	09 05 248 2832 09 05 248 2831 09 05 248 2831 222 ^{f)} 09 05 748 2831 ^{c)}
	48						
	48						
Female connector with wrap posts 20 mm	48		09 05 248 7821		09 05 248 6821		09 05 248 2821
Female connector with solder lugs	48		09 05 248 7823		09 05 248 6823		09 05 248 2823
Female connector with press-in pins 11,5 mm	48				09 05 248 6851* 09 05 248 6851 222 ^{f)}		09 05 248 2851*

Dimensions

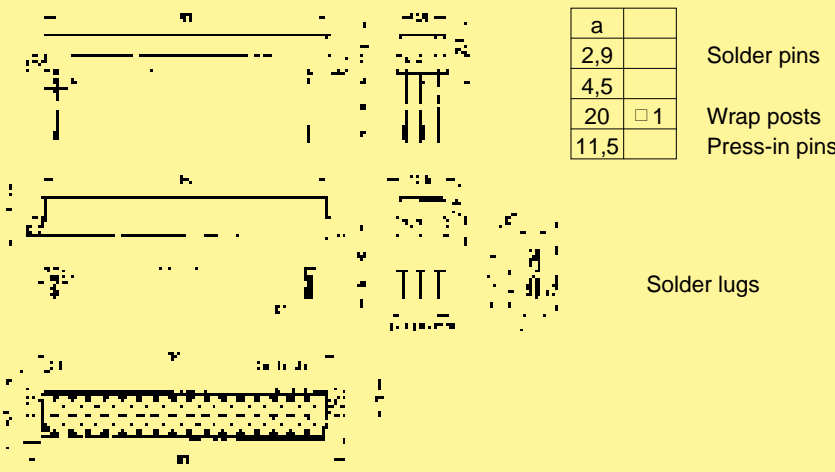

Panel cut out

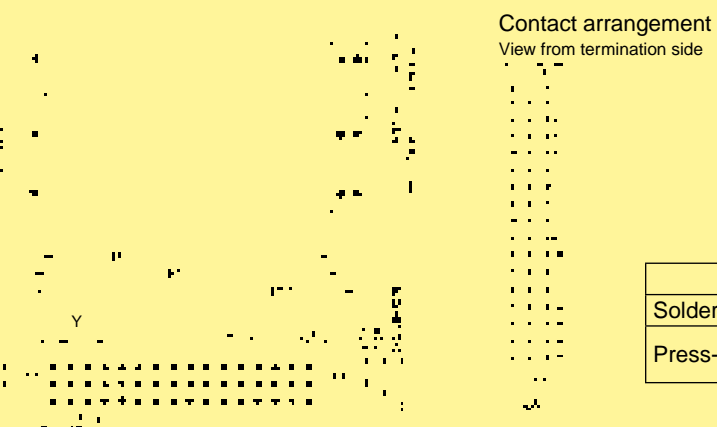

Board drillings

Mounting side

	Y
Solder	1 ± 0.1
Press-in	see recommendation page 00.25

Dimensions in mm

• Wrap posts for interfacing selectively gold plated (performance level 2)
 b) Connectors with snap-in clips see chapter 00
 c) Connectors with coding see chapter 00
 f) Railway classification NFF 16-101, Smoke index: F1, Flammability class: I2

Pin shroud



Number of contacts

48

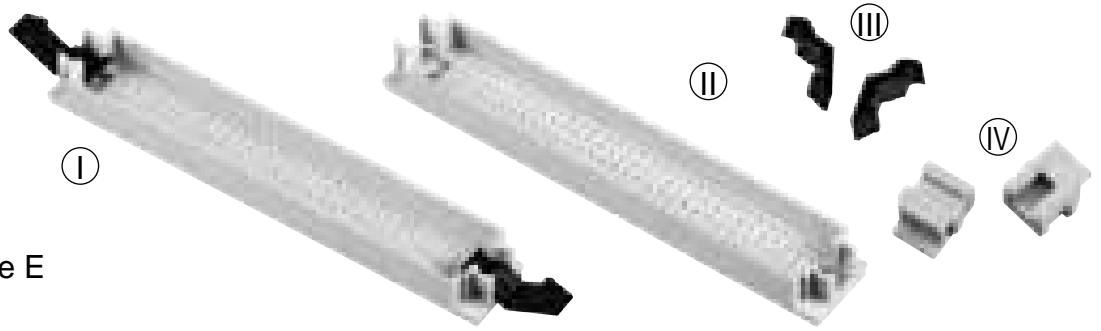

Pin shrouds for type E
with press-in pins

Identification	pcb-thickness + 0.2 / - 0.3	Dimension X - 0.1	Part No.
Pin shrouds			
(I) with locking levers	2.8	3.6	09 05 000 9924
(II) without locking levers	2.8	3.6	09 05 000 9914 ¹⁾
(I) with locking levers	3.4	3.0	09 05 000 9922
(II) without locking levers	3.4	3.0	09 05 000 9912 ¹⁾
(III) Locking lever for female connector type E ¹⁾			09 03 000 9914
(IV) Fixing brackets for shell housing C ¹⁾			09 03 000 9921 ¹⁾

DIN Power
up to 6 A

Dimensions

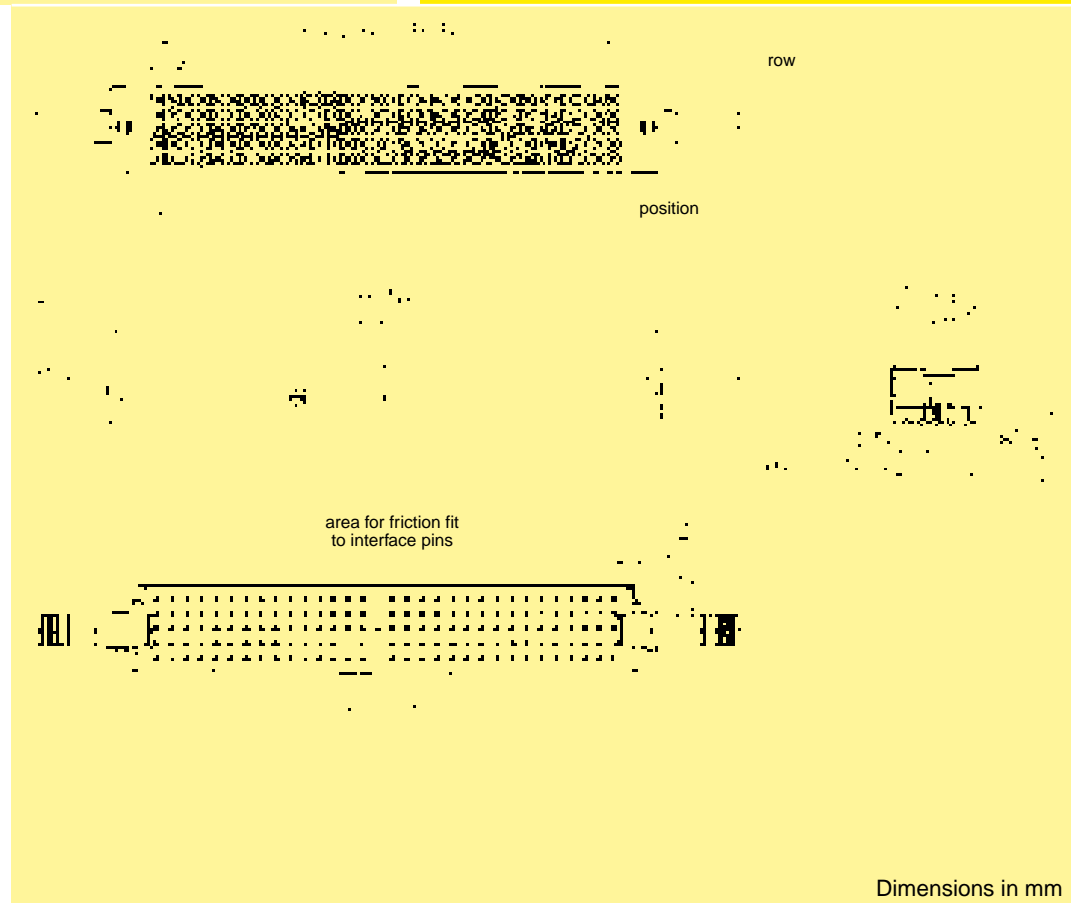

Dimensions in mm

03
19

¹⁾ order 2 pieces per connector

²⁾ Railway classification NFF 16-101, Smoke index: F1, Flammability class: I2



Application 1

Female connector
09 05 248 6851



Backplane

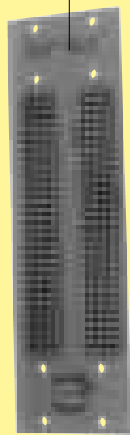

Pin shroud
09 05 000 9912



Fixing brackets
09 03 000 9921



Shell housing C
09 05 048 0501

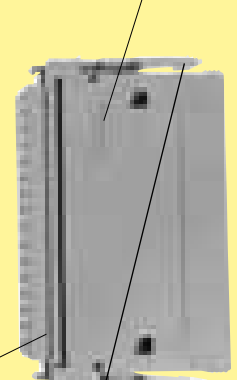

Female connector
with crimp contacts
09 05 048 3202

Locking lever
left 09 02 000 9902
right 09 02 000 9903

Application 2

Female connector
09 05 248 6851



Backplane

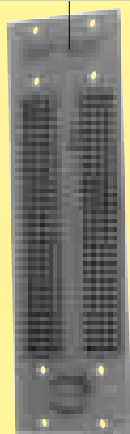

Pin shroud
09 05 000 9912



Locking lever
09 03 000 9914



Female connector
for crimp contacts
09 05 048 3202

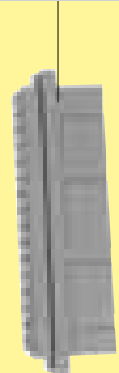

DIN Power
up to 6 A

Application 1

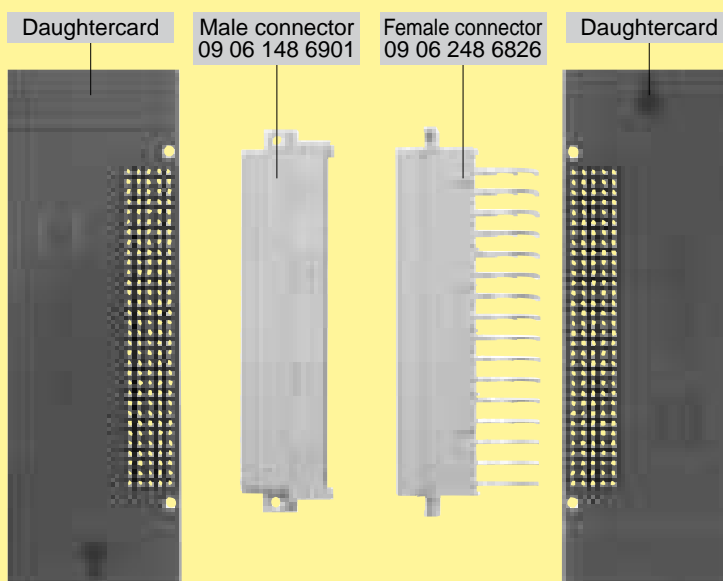

Application 2

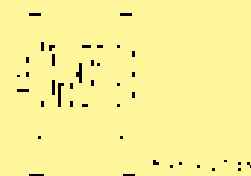
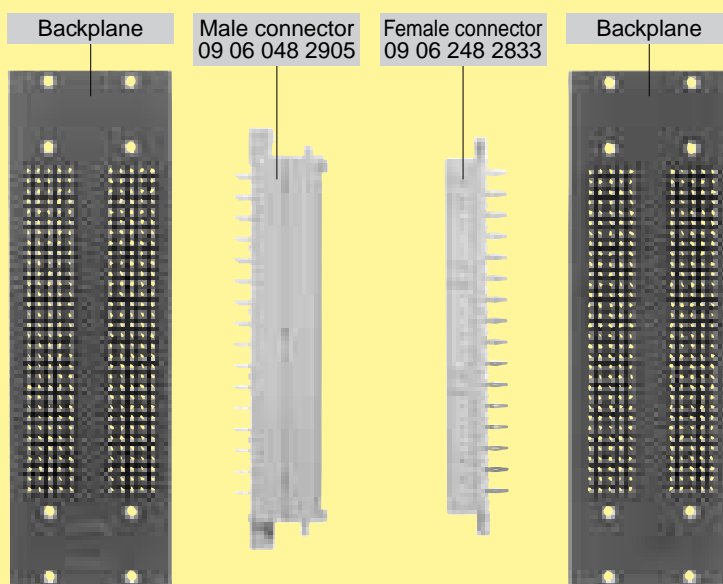

DIN Power
up to 6 A



Number of contacts	16, 32, 48
Working current see current carrying capacity chart	6 A max.
Clearance	
16 ways	≥ 1.6 mm
32, 48 ways	≥ 1.6 mm
Creepage	
16 ways	≥ 1.6 mm
32, 48 ways	≥ 3.0 mm
Working voltage	
The working voltage also depends on the clearance and creepage dimensions of the pcb itself and the associated wiring	according to the safety regulations of the equipment Explanations see chapter 00
Contact resistance	≤ 20 mΩ
Insulation resistance	≥ 10 ¹² Ω for standard articles

Termination	Crimp terminal 0.09-1.5 mm ²
-------------	--

Materials	
Mouldings and hoods	Thermoplastic resin, glass-fibre filled
Contacts	Copper alloy

Piggyback connectors for interfacing with female connectors with wrap posts 1 x 1 mm

The problem of interfacing systems designed for the distribution or collection of electronic signals can be overcome by the use of piggyback connectors. Designed to be mounted on the rear of DIN 41 612 type wire wrap female connectors (1 x 1 mm posts) these piggyback elements can be used to terminate input and output cables.

Distance fixing brackets are fitted to provide either a latching or screw fixing facility over the two level wire wrap plane.

The female crimp contacts used in these versions are designed for 1 x 1 mm posts.

After crimping they can be easily inserted into the chambers of the connector body with the aid of an insertion tool. Insertion errors can be simply rectified with the use of a removal tool.

2 and 3 row piggyback connectors can be mounted in shell housings C and open hood G. Security is provided by either latches or screws to the distance fixing brackets.

Current carrying capacity

The current carrying capacity is limited by maximum temperature of materials for inserts and contacts including terminals. The current capacity curve is valid for continuous, non interrupted current loaded contacts of connectors when simultaneous power on all contacts is given, without exceeding the maximum temperature.

Control and test procedures according to DIN IEC 60 512

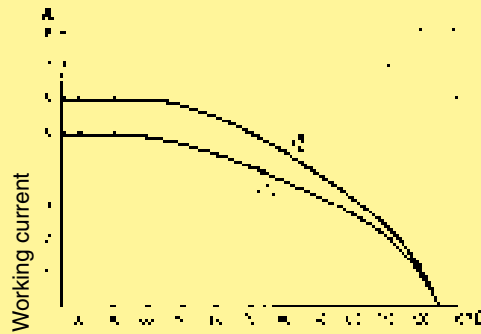

Ambient temperature

- ① with shell housing
- ② without shell housing

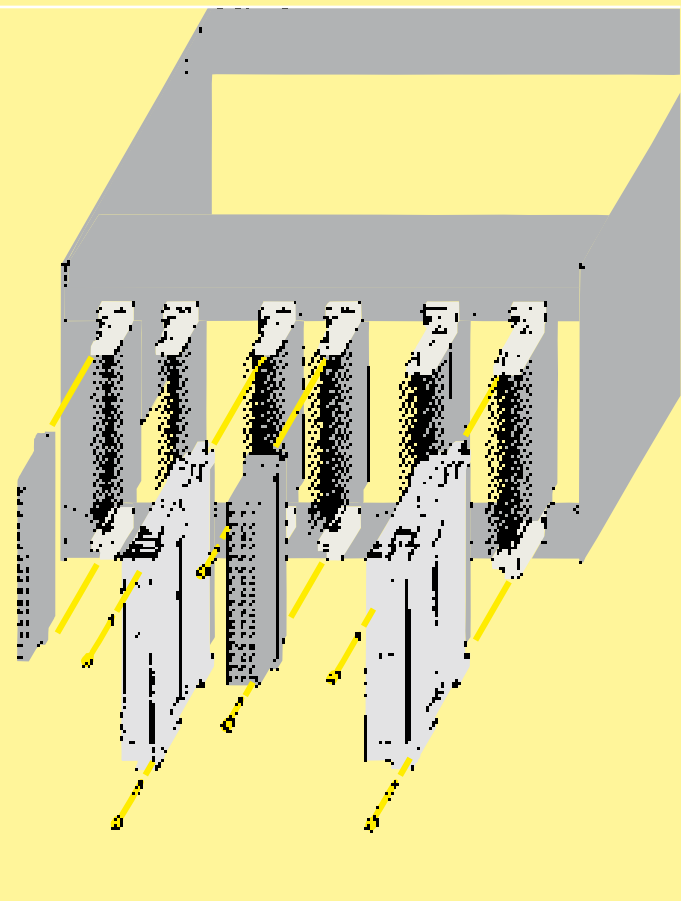

Number of contacts

max. 48

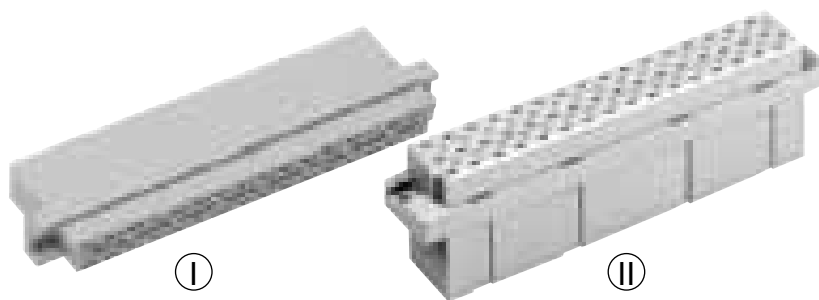

Piggyback connectors for 1 x 1 mm wrap posts

Identification	Number of contacts	Part No.	Drawing	Dimensions in mm
Piggyback connector for crimp contacts Order contacts separately (I)	16	09 04 016 3201 ¹⁾		
	32	09 04 032 3215 ¹⁾		
	48	09 05 048 3204 ¹⁾		

DIN Power up to 6 A

¹⁾ Railway classification NFF 16-101, Smoke index: F1, Flammability class: I2

Number of contacts

max. 48

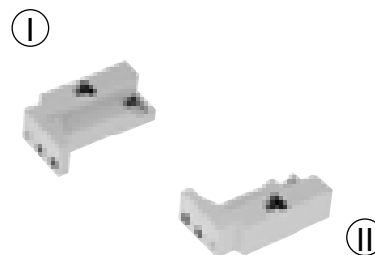

Accessories

DIN Power
up to 6 A

Identification	Number of contacts	Part No.	Drawing	Dimensions in mm
----------------	--------------------	----------	---------	------------------

Female FC crimp contacts

individual contacts ¹⁾	FC1	09 06 000 6464
	FC2	
	FC3	
Bandoliered contacts (approx. 2,500 pcs.)	FC1	09 06 000 6454
	FC2	
	FC3	

Identi- fication	Wire gauge mm ²	AWG	Insulations ø mm
1	0.09-0.25	28-24	0.7-1.5
2	0.14-0.56	26-20	0.8-2.0
3	0.50-1.50	20-16	1.6-2.8

3.5 + 0.5 mm of insulation is stripped from the wires to be crimped.
For the fabrication in line with the specification please use exclusively crimp tools approved by HARTING (see DIN EN 60352-2)
Crimping tools see chapter 30

Mateable with
1 x 1 mm wrap posts

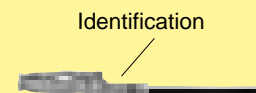

Distance fixing brackets for female connectors

Type D
Type E

top (pos. 2) 09 04 000 9907 ¹⁾
bottom (pos. 32) 09 04 000 9906 ¹⁾

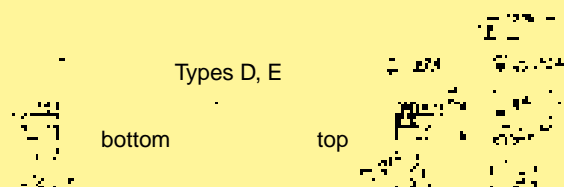

Type F



top (pos. 2) 09 06 000 9936 ¹⁾
bottom (pos. 32) 09 06 000 9937 ¹⁾

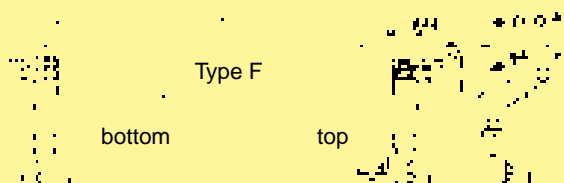

¹⁾ Packaging unit 1,000 pieces

²⁾ Railway classification NFF 16-101, Smoke index: F1, Flammability class: I2

Identification

Drawing

Dimensions in mm

Mounting examples
of piggyback
connectors

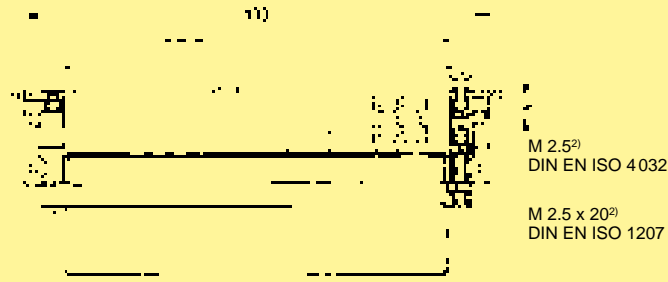

without housings

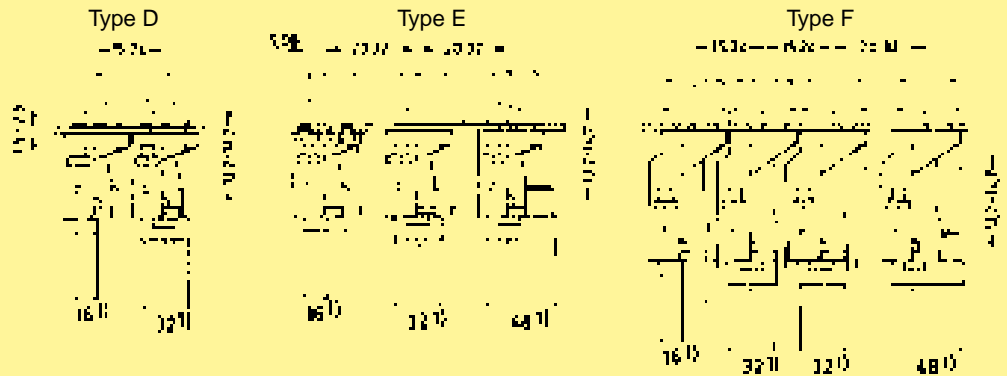

with housings

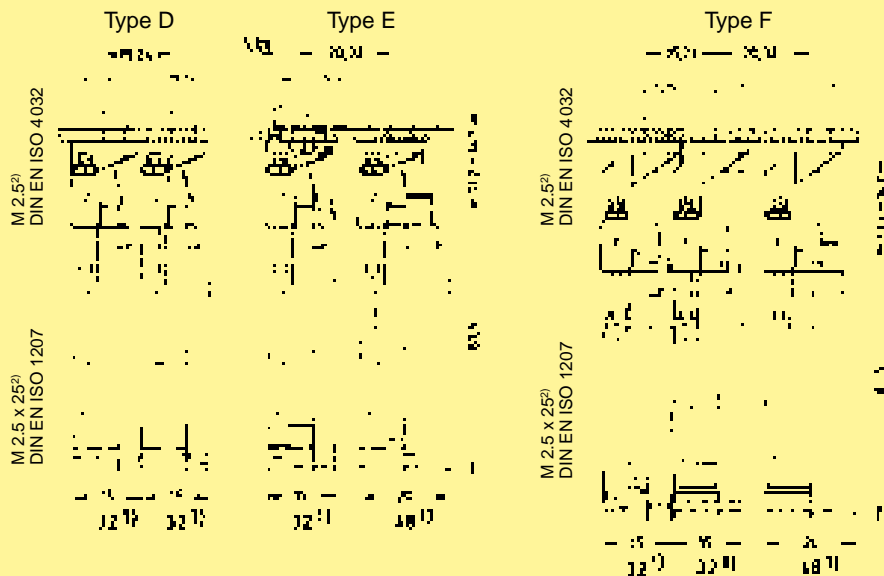
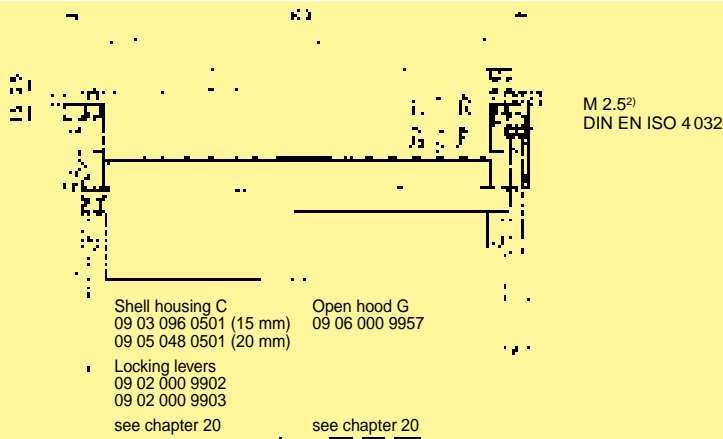

DIN Power
up to 6 A

1) Number of contacts piggyback connector
2) Doesn't belong to the scope of supply



Number of contacts

Type F	48, 32
Type FM	45
Type 2F	max. 24
Type F9	max. 9

Contact spacing (mm)

5.08

Working current

6 A max.

see current carrying capacity chart

Clearance

≥ 1.6 mm

Creepage

≥ 3.0 mm

Working voltage

The working voltage also depends on the clearance and creepage dimensions on the pcb itself and the associated wiring

according to the safety regulations of the equipment
Explanations see chapter 00

Test voltage $U_{r.m.s.}$

1.55 kV (contact-contact)
2.5 kV (contact-ground)

Contact resistance

≤ 15 mΩ

Insulation resistance

≥ 10¹² Ω for standard articles
≥ 10¹¹ Ω for special NFF articles
(with part-no. ending 222)

Temperature range

– 55 °C ... + 125 °C

The higher temperature limit includes the local ambient and heating effects of the contacts under load

– 40 °C ... + 105 °C
for press-in connector

During reflow soldering

max. + 240 °C for 15 s
for SMC connectors

Electrical termination

Solder pins for pcb connections Ø 1 ± 0.1 mm according to IEC 60 326-3
Wrap posts 1 x 1 mm diagonal 1.34-1.45 mm
Crimp terminal 0.09-1.5 mm²
Angled solder pins 1 x 1 mm for pcb connections Ø 1.6 ± 0.1 mm
Solder lugs
Compliant press-in terminations
pcb thickness ≥ 1.6 mm
Recommended pcb holes for press-in technology See recommendation page 00.25 in acc. to EN 60 352-5

Insertion and withdrawal force

48 way ≤ 75 N
45 way ≤ 70 N
32 way ≤ 50 N
24 way ≤ 37 N

Materials

Mouldings

Thermoplastic resin, glass-fibre filled, UL 94-V0
Copper alloy

Contacts

Contact surface

Contact zone

Selectively plated according to performance level¹⁾

¹⁾ Explanation of performance levels see chapter 00

Current carrying capacity

The current carrying capacity is limited by maximum temperature of materials for inserts and contacts including terminals. The current capacity curve is valid for continuous, non interrupted current loaded contacts of connectors when simultaneous power on all contacts is given, without exceeding the maximum temperature.

Control and test procedures according to DIN IEC 60 512

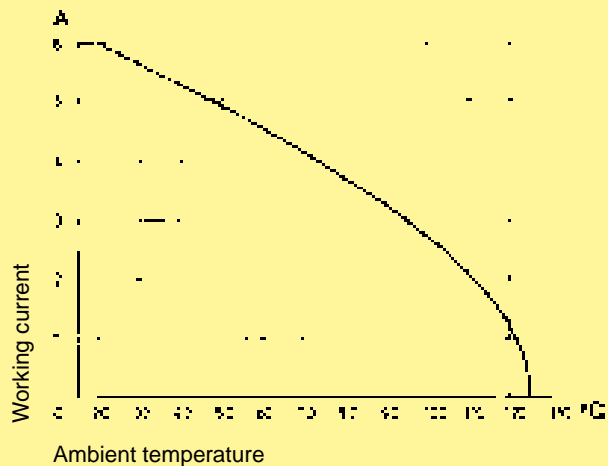

Fitting the crimp contacts

After crimping the wires onto the contacts with the help of a crimping tool or an automatic crimping machine the contacts should be correctly oriented and inserted into the cavities of the connector moulding in the required configuration. They snap into position and are firmly held in place. A light pull on the wire assures the correct tensile strength of the contact. When using stranded wires with a gauge below 0.37 mm² an insertion tool is necessary.

Removing the crimp contacts

The removal tool is inserted into a slot on the side of the respective crimp cavity. This action compresses the contact retaining spring therefore the contact can then be easily withdrawn using a light pull on the wire. This action will cause no damage to the contact/wire which can be repositioned/refitted as necessary. The drawing demonstrates the crimp removal procedure (max. 5x).

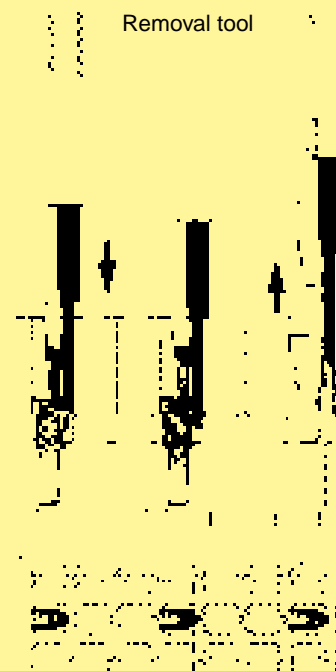

Number of contacts

48, 32

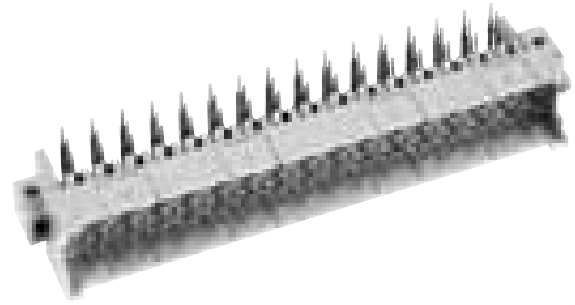

Male connectors

Identification	Number of contacts	Contact arrangement	Part No. Performance levels according to IEC 60603-2. Explanation chapter 00			
			3	2	1	
Male connector with angled solder pins ¹⁾	48		09 06 148 7901	09 06 148 6901 09 06 148 6901 222 ^{f)} 09 06 348 6901 ^{b)} 09 06 348 6901 222 ^{b)f)}	09 06 148 2901 09 06 148 2901 222 ^{f)}	
			09 06 348 7951 ^{b)d)}	09 06 148 6951 ^{d)} 09 06 348 6951 ^{b)d)}	09 06 348 2951 ^{b)d)}	
	32		09 06 132 7901 09 06 332 7901 ^{b)}	09 06 132 6901 09 06 132 6901 222 ^{f)}	09 06 132 2901	
			09 06 132 7931	09 06 132 6931 09 06 132 6931 222 ^{f)} 09 06 332 6931 ^{b)}	09 06 132 2931	
	1 leading contact (position z 32)	47 + 1			09 06 148 6921 09 06 348 6921 ^{b)}	09 06 148 2921
		31 + 1		09 06 132 7921	09 06 132 6921	09 06 132 2921
2 leading contacts (positions b 2 + b 32)	46 + 2			09 06 148 6925 09 06 148 6925 222 ^{f)}	09 06 148 2925	

DIN Power up to 6 A

Dimensions



Board drillings

Mounting side



Cross section of solder terminations

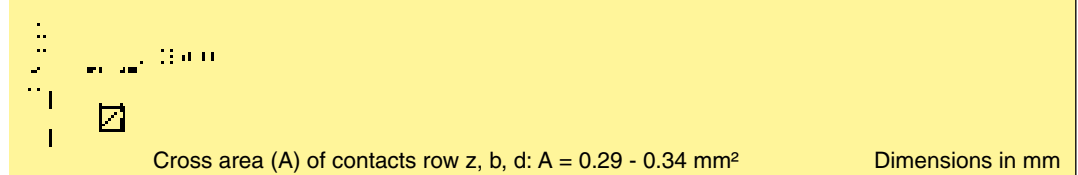

Dimensions in mm

1) With shroud coding, see also chapter 00
 b) Connectors with snap-in clips see chapter 00
 d) CTI > 400
 f) Railway classification NFF 16-101, Smoke index: F1, Flammability class: I2

Number of contacts

48, 32

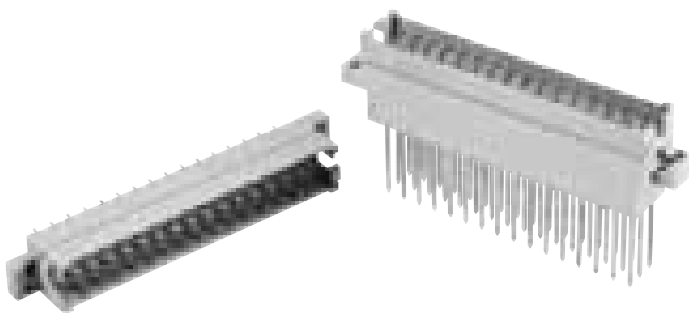

Interface connectors I

DIN Power
up to 6 A

Identification	Number of contacts	Contact arrangement	Part No.	Drawing	Dimensions in mm
Interface connector I with solder pins ¹⁾ 0.6 x 0.6 mm	48		Performance level 1* 09 06 048 2905 ^{f)}		
	32		09 06 032 2905 ^{f)}		
	32		09 06 032 2941 ^{f)}		
Board drillings Mounting side					
Interface connector I with wrap posts ¹⁾ 1 x 1 mm	without nut		Performance level 1* 09 06 048 2903 ^{f)}		
	with nut		09 06 048 2963 ^{f)}		
	without nut		09 06 032 2903 ^{f)}		
Panel cut out					

* Acc. to IEC 60 603-2, performance level 2 on request
¹⁾ With shroud coding, see also chapter 00
^{f)} Railway classification NFF 16-101, Smoke index: F1, Flammability class: I2

Number of contacts

48

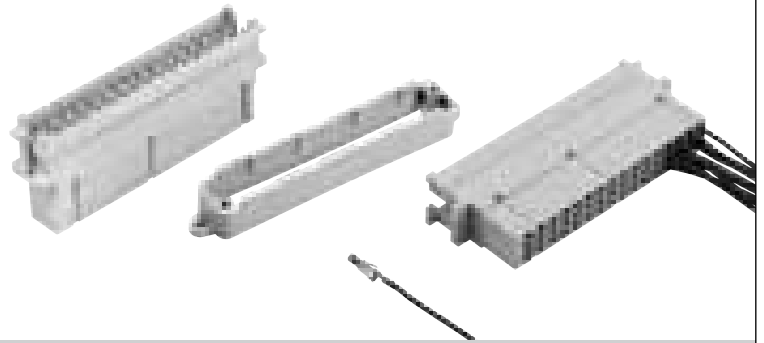

Interface connector I

Identification	Number of contacts	Part No.	Drawing	Dimensions in mm
----------------	--------------------	----------	---------	------------------

Interface connector I utilising female crimp contacts¹⁾
 Order crimp contacts separately see page 03.31

48

Performance level 1 acc. to IEC 60 603-2
 09 06 048 2906¹⁾



Contact arrangement View from termination side

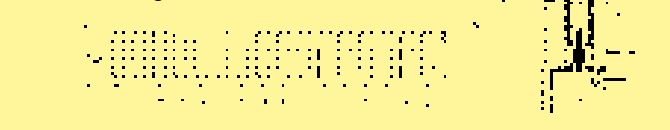

Shell housing see chapter 20

Panel cut out

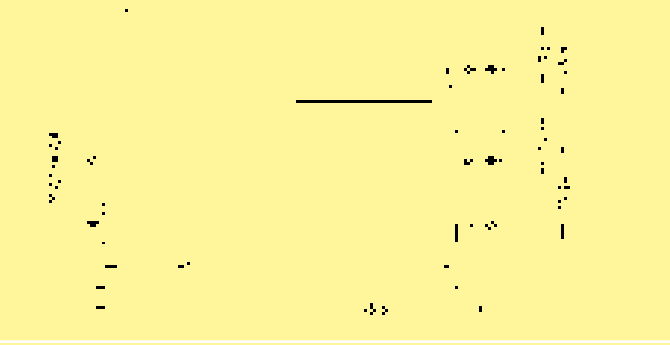

Shroud¹⁾
 for screw-fixing of shell housing D20 plastic or D20 metallised .
 The shroud is assembled onto the Interface connector I and is screwfixed onto the pcb or to the rack.

09 06 001 9964

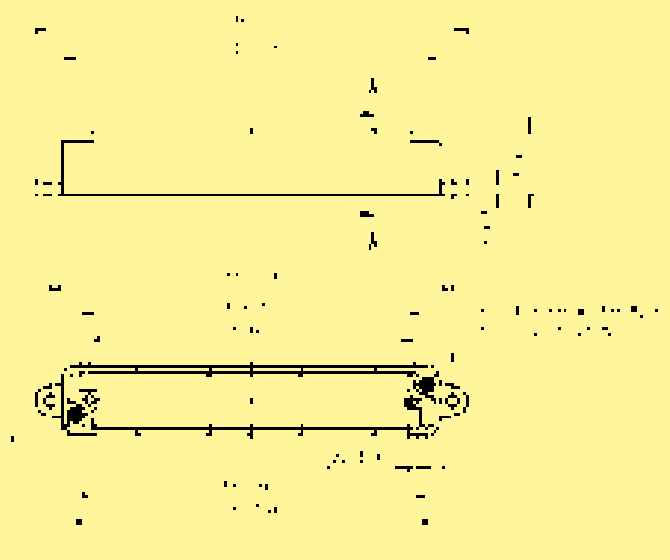

DIN Power up to 6 A

¹⁾ With shroud coding, see also chapter 00
¹⁾ Railway classification NFF 16-101, Smoke index: F1, Flammability class: I2



Number of contacts

48

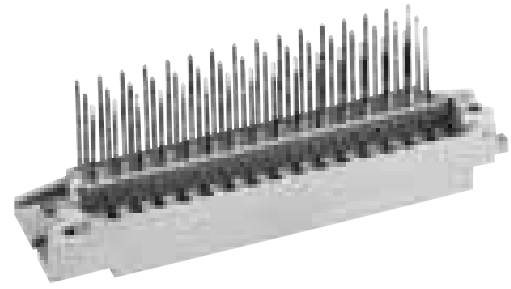

Interface connector U

Identification	Number of contacts	Part No.	Drawing	Dimensions in mm
----------------	--------------------	----------	---------	------------------

Interface connector U
with wrap posts
1 x 1 mm

48

Performance level 1
acc. to IEC 60 603-2

09 06 048 2981¹⁾



Contact arrangement View from termination side

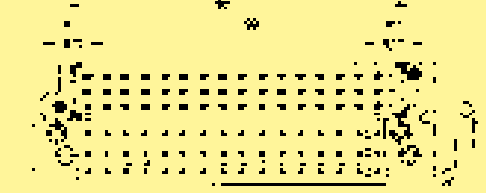

Mounting example

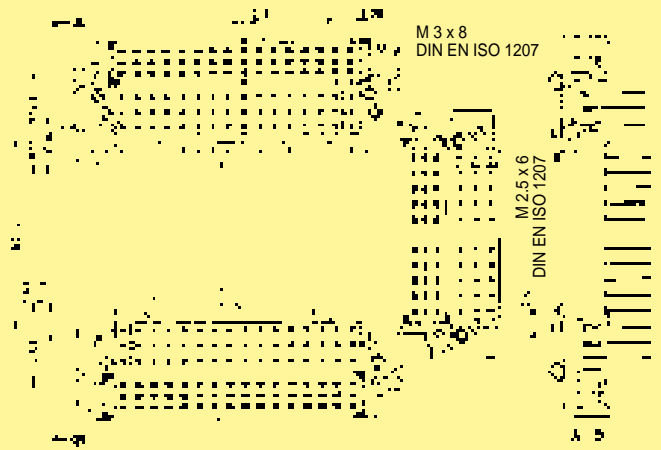

DIN Power
up to 6 A

¹⁾ Railway classification NFF 16-101, Smoke index: F1, Flammability class: I2

Number of contacts

max. 48

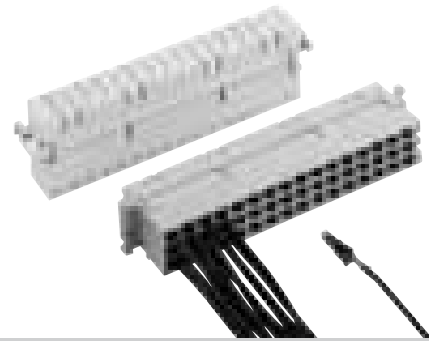

Female connectors

Identification	Number of contacts	Part No.	Drawing	Dimensions in mm
Female connector for crimp contacts ¹⁾ Order contacts separately	48	09 06 248 3201 09 06 248 3201 222 ^{f)}	<p>Contact arrangement View from termination side</p> <p>Shell housing see chapter 20</p>	

DIN Power up to 6 A

Identification	Identification Wire gauge	Part No.	Performance levels according to IEC 60603-2. Explanation chapter 00
			2 1
Female crimp FC contacts			
Bandoliered contacts (approx. 2,500 pieces)	1	09 06 000 6484	09 06 000 6474
	2	09 06 000 6481	09 06 000 6471
	3	09 06 000 6482	09 06 000 6472
Bandoliered contacts (approx. 250 pieces)	1	09 06 000 7484	09 06 000 7474
	2	09 06 000 7481	09 06 000 7471
	3	09 06 000 7482	09 06 000 7472
Individual contacts ²⁾	1	09 06 000 8484	09 06 000 8474
	2	09 06 000 8481	09 06 000 8471
	3	09 06 000 8482	09 06 000 8472
Female contacts with solder lugs ³⁾ (lockable)			09 06 000 6420

	FC 1	FC 2	FC 3	Wire gauge mm ²	AWG	Insulation ø mm	Identification
				0.09 - 0.25	28 - 24	0.7 - 1.5	<p>Bandoliered contacts</p> <p>Individual contacts</p>
				0.14 - 0.56	26 - 20	0.8 - 2.0	
				0.5 - 1.5	20 - 16	1.6 - 2.8	
				3.5 + 0.5 mm of insulation is stripped from the wires to be crimped			
				For the fabrication in line with the specification please use exclusively crimp tools approved by HARTING (see DIN EN 60352-2)			
				Insertion, removal and crimping tools see chapter 30			

¹⁾ With shroud coding, see also chapter 00

²⁾ Packaging unit 1,000 pieces

³⁾ Solder contacts must not be used together with shell housing A. Special contact surface: 2 µm gold.

^{f)} Railway classification NFF 16-101, Smoke index: F1, Flammability class: I2

Number of contacts

48, 32

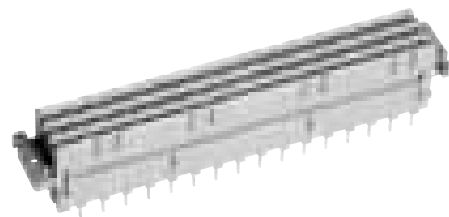

Female connectors

DIN Power
up to 6 A

Identification	Number of contacts	Contact arrangement	Part No. Performance levels according to IEC 60 603-2. Explanation chapter 00		
			3	2	1
Female connector with solder pins 3.7 mm ¹⁾	48			09 06 248 6848	09 06 248 2848
	32			09 06 232 6848	09 06 232 2848
	32			09 06 232 6858	
Female connector with solder pins 4.5 mm ¹⁾	48		09 06 248 7835	09 06 248 6835 09 06 248 6835 222 ^{f)}	09 06 248 2835
	32			09 06 232 6835	09 06 232 2835
	32			09 06 232 6845	09 06 232 2845

Dimensions

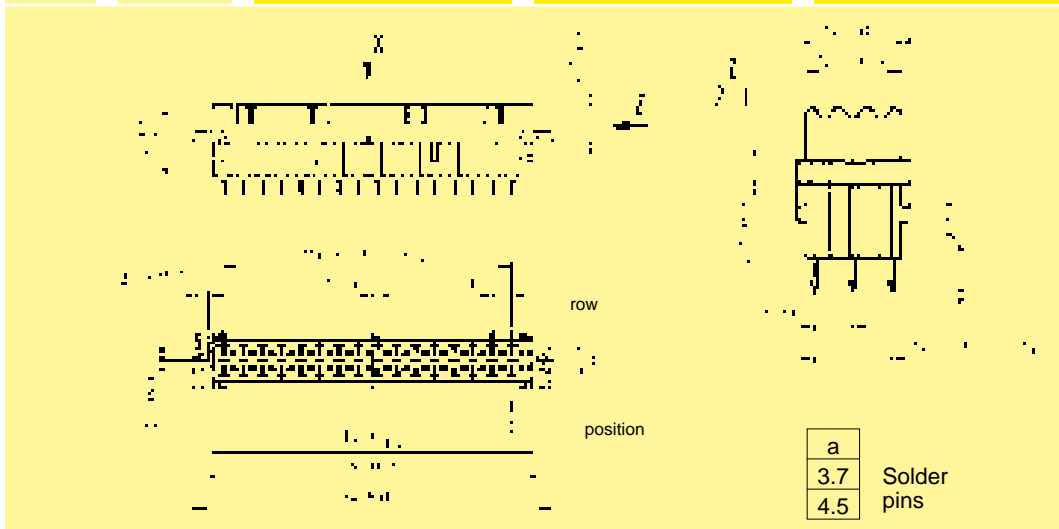

Board drillings

Mounting side

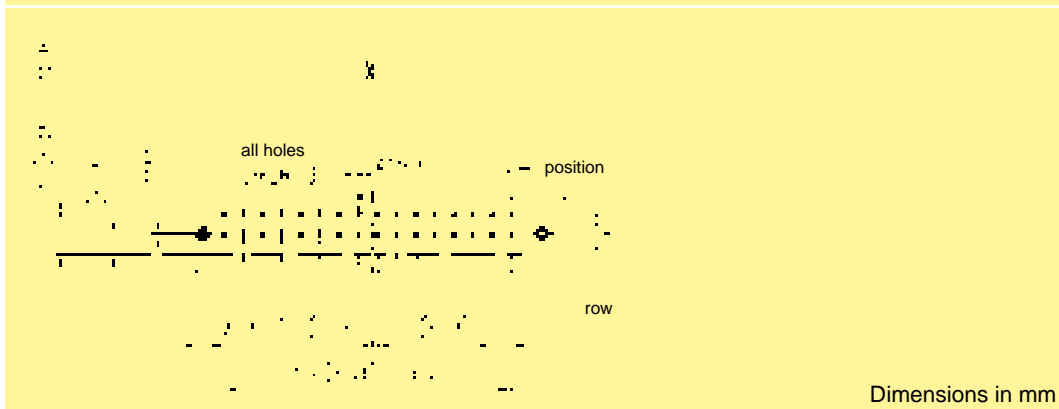

Dimensions in mm

¹⁾ With shroud coding, see also chapter 00

^{f)} Railway classification NFF 16-101, Smoke index: F1, Flammability class: I2

Number of contacts

48, 32

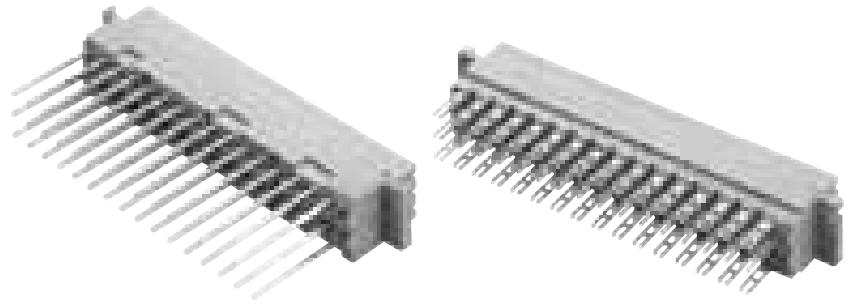

Female connectors

Identification	Number of contacts	Contact arrangement	Part No. Performance levels according to IEC 60 603-2. Explanation chapter 00		
			3	2	1
Female connector with wrap posts 22 mm	48		09 06 248 7821	09 06 248 6821 09 06 248 6821 222 ¹⁾	09 06 248 2821 09 06 248 2821 222 ¹⁾
	32		09 06 232 7821	09 06 232 6821	09 06 232 2821
	32		09 06 232 7831	09 06 232 6831	09 06 232 2831
Female connector with solder lugs open solder lug 	48		09 06 248 7823	09 06 248 6823	09 06 248 2823
	32		09 06 232 7823	09 06 232 6823	09 06 232 2823
	32		09 06 232 7843	09 06 232 6843 09 06 232 6843 222 ¹⁾	09 06 232 2843

DIN Power up to 6 A

Dimensions

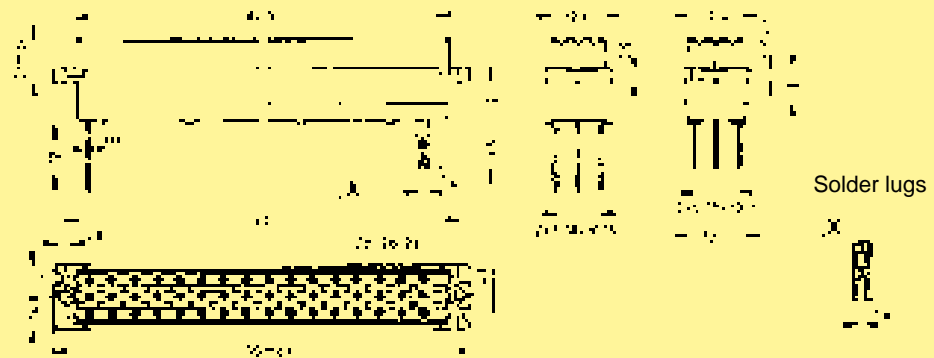

Panel cut out

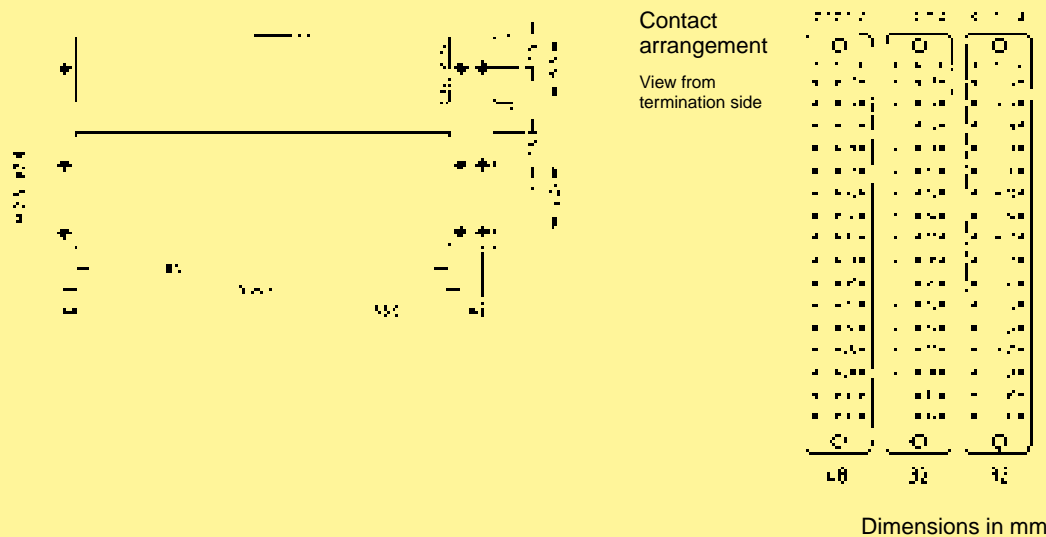

Dimensions in mm

03
33

Number of contacts

48, 32

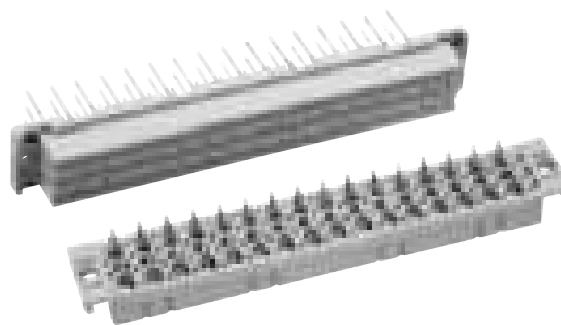

Female connectors

DIN Power
up to 6 A

Identification	Number of contacts	Contact arrangement	Part No. Performance levels according to IEC 60 603-2. Explanation chapter 00		
			3	2	1
Female connector ¹⁾ "low profile" with solder pins 3.7 mm	48		09 06 248 7833	09 06 248 6833 09 06 248 6833 222 ^{f)}	09 06 248 2833 09 06 248 2833 222 ^{f)}
	32			09 06 232 6833	
	32			09 06 232 6893	
Female connector ¹⁾ "low profile" with solder pins 4.5 mm	48		09 06 248 7834	09 06 248 6834 09 06 248 6834 222 ^{f)}	09 06 248 2834
	32			09 06 232 6834	
	32			09 06 232 7894	09 06 232 6894
Female connector ¹⁾ "low profile" with press-in pins 4.5 mm	48		09 06 248 7832	09 06 248 6832	09 06 248 2832 09 06 248 2832 222 ^{f)}
	32			09 06 232 6832	09 06 232 2832 09 06 232 2832 222 ^{f)}
	32			09 06 232 6892	
Female connector "low profile" with press-in pins 13 mm	48		09 06 248 7837	09 06 248 6837	
	32			09 06 232 6897	

Dimensions

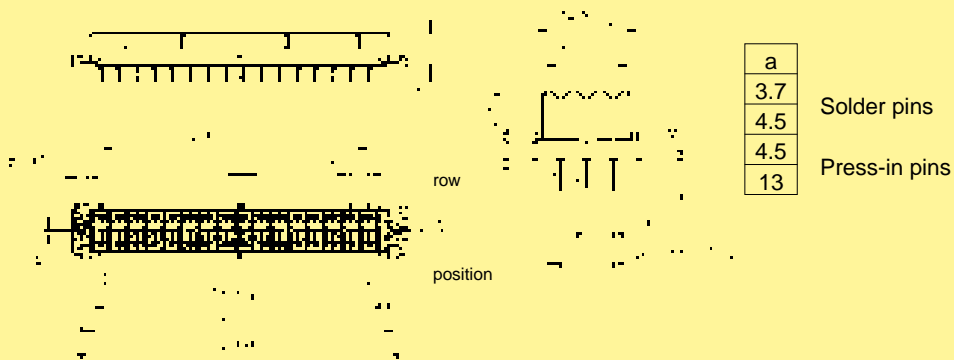

Board drillings

Mounting side

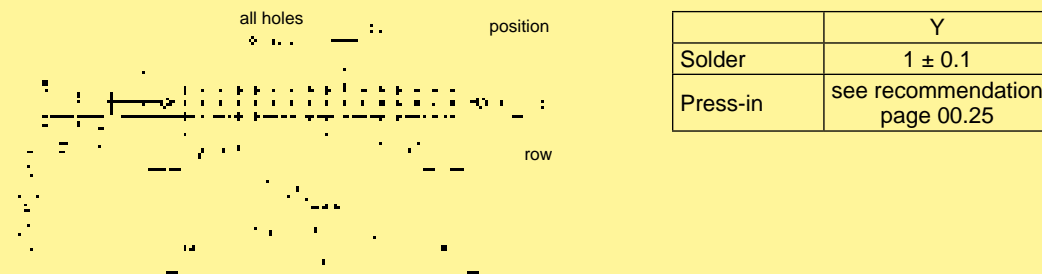

Dimensions in mm

¹⁾ With shroud coding, see also chapter 00

^{f)} Railway classification NFF 16-101, Smoke index: F1, Flammability class: I2

Number of contacts

48, 32

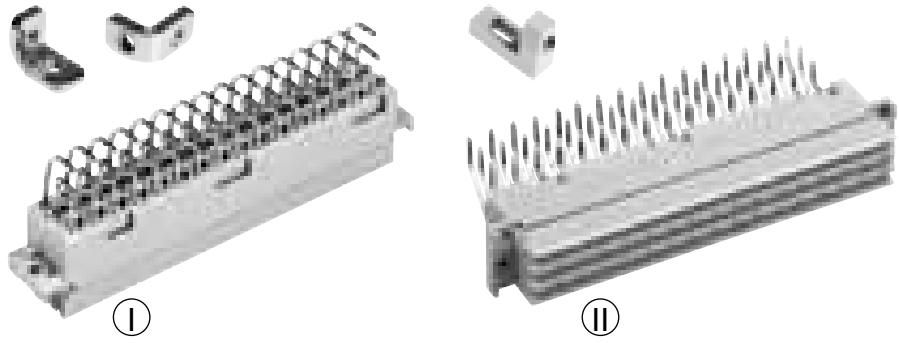

Female connectors

Identification Number of contacts Contact arrangement Part No. Performance levels according to IEC 60 603-2. Explanation chapter 00

			3	2	1
Female connector with angled solder pins 1 x 1 mm	48	Ⓚ	Performance level 3 on request	09 06 248 6826	Performance level 1 on request
	32			09 06 232 6826	
	48	Ⓛ		09 06 248 6836	
	32			09 06 232 6846	
	32			09 06 232 6836	

DIN Power up to 6 A

Dimensions

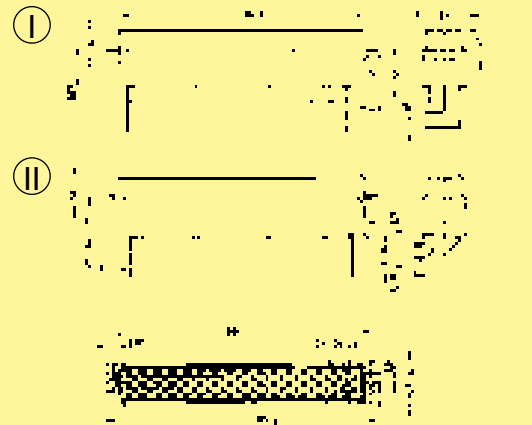

Fixing bracket

¹⁾ Order 2 pieces for one connector

Metal	09 06 000 9912 ¹⁾
Plastic	09 06 000 9975 ¹⁾

for version Ⓚ

for version Ⓛ

Board drillings
Mounting side

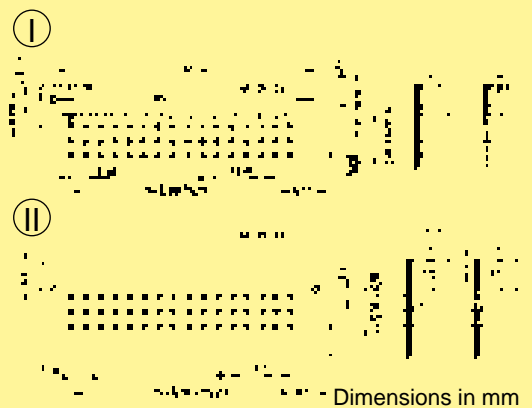

Dimensions in mm



Number of contacts

64, 16

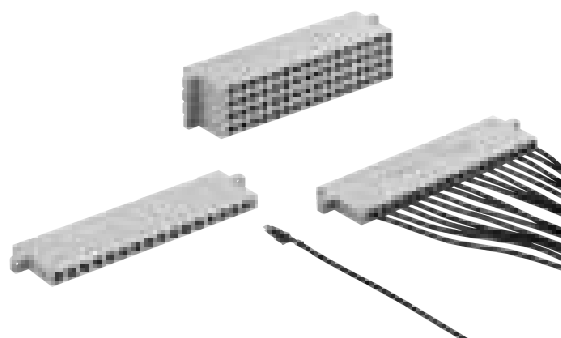

Universal adaptors

DIN Power
up to 6 A

Identification	Number of contacts	Part No.	Drawing	Dimensions in mm
Universal adaptor utilising crimp contacts crimp contacts see page 03.31	4 x 4	09 06 016 3301 ¹⁾		
	16 x 1	09 06 016 3302 ¹⁾		
	16 x 4	09 06 064 3302 ¹⁾		
Panel cut out				

¹⁾ Railway classification NFF 16-101, Smoke index: F1, Flammability class: I2

Number of contacts

max. 9

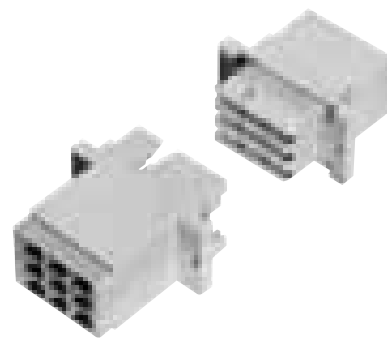

Female and male connectors

Identification	Number of contacts	Part No.	Drawing	Dimensions in mm
Female connector for crimp contacts Order contacts separately	9	09 06 209 3201		
Female crimp contacts		see page 03.31		
Male connector for crimp contacts Order contacts separately	9	09 06 109 3401		
Male crimp contacts		see page 03.40		

DIN Power up to 6 A

DIN 41 612 · complementary type FM



Number of contacts

45

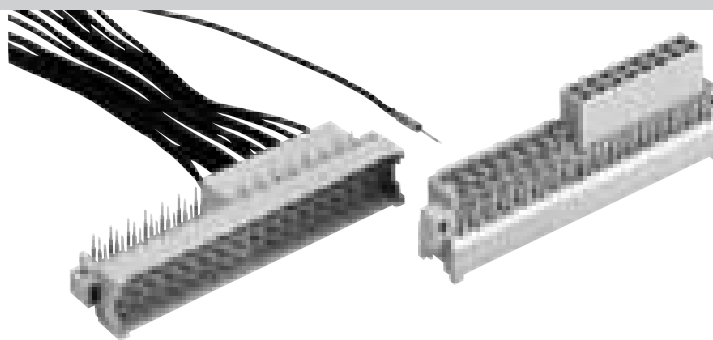

Male connectors

Identification	Number of contacts	Part No.	Drawing	Dimensions in mm
----------------	--------------------	----------	---------	------------------

Male connector

29 angled solder pins
16 cavities for male crimp contacts

45

Performance level 1
acc. to IEC 60 603-2

09 06 145 2971

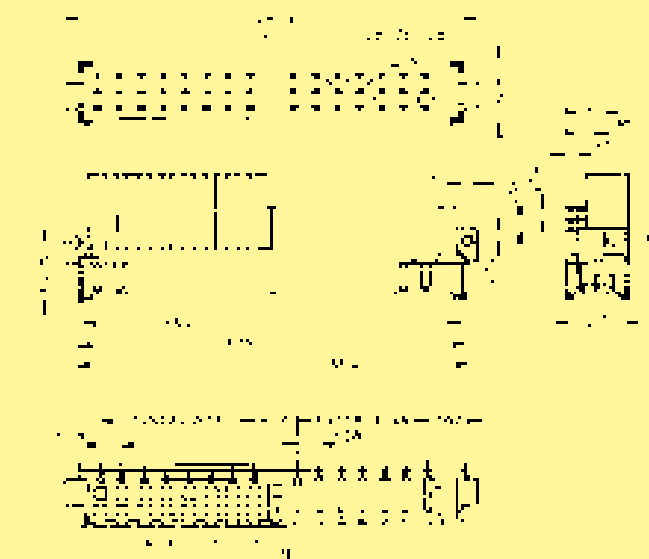

crimp contacts
see page 03.40

Board drillings
Mounting side

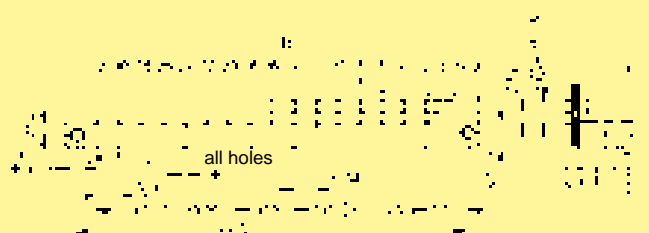

1) A special 48 way version with 3 extra angled solder contacts at position 16 (rows d, b, z) can be supplied

Number of contacts

45

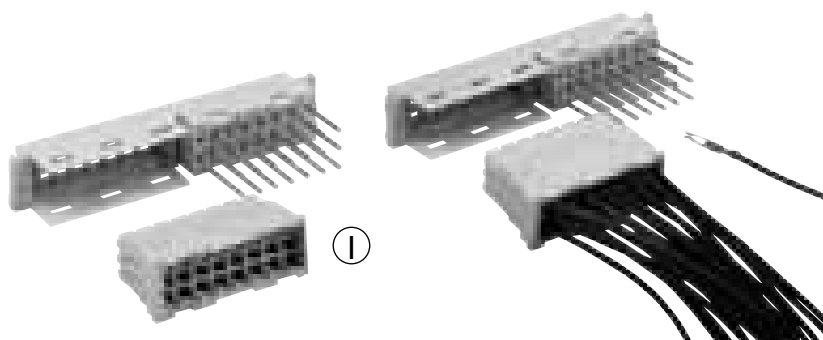

Female connectors

Identification	Number of contacts	Part No.	Drawing	Dimensions in mm
<p>Female connector</p> <p>Female moulding with 21 wrap posts 22 mm</p> <p>with 21 solder pins 4.5 mm</p>	45	<p>Performance level 1 acc. to IEC 60 603-2</p> <p>09 06 045 2871^{f)}</p> <p>09 06 045 2875^{f)}</p>	<p>Latches</p> <p>Crimp moulding is supplied with the female moulding</p> <p>Contact arrangement View from termination side</p>	
<p>Crimp moulding for 24 female crimp contacts</p> <p>crimp contacts see page 03.31</p>	45	09 06 024 3202 ^{f)}		
<p>Panel cut out</p>				
<p>Removal tool for the crimp moulding</p>		09 99 000 0172	<p>The crimp moulding can be extracted with the help of the removal tool.</p>	

DIN Power
up to 6 A

^{f)} Railway classification NFF 16-101, Smoke index: F1, Flammability class: I2

Number of contacts

max. 24

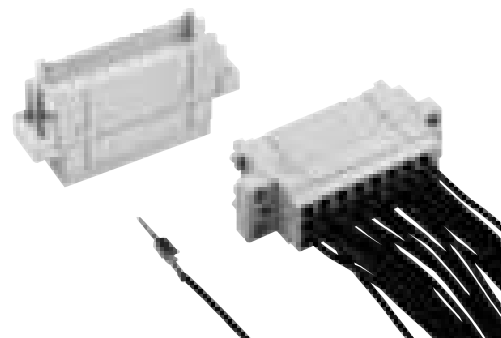

Interface connector I

DIN Power
up to 6 A

Identification	Number of contacts	Part No.	Drawing	Dimensions in mm
Interface connector I for male crimp contacts Order contacts separately	24	09 26 024 3411		

Identification	Identification Wire gauge	Part No.	Performance levels according to IEC 60603-2. Explanation chapter 00
			2 1
Male crimp FC contacts			
Bandoliered contacts (approx. 2,500 pieces)	1 2 3	09 06 000 9564 09 06 000 9561 09 06 000 9562	09 06 000 9544 09 06 000 9541 09 06 000 9542
Bandoliered contacts (approx. 250 pieces)	2 3		09 06 000 5541 09 06 000 5542
Individual contacts ¹⁾	1 2 3	09 06 000 9574 09 06 000 9571 09 06 000 9572	09 06 000 9554 09 06 000 9551 09 06 000 9552

	FC 1	FC 2	FC 3	Wire gauge mm ²	AWG	Insulation ø mm	Identification
				0.09 - 0.25	28 - 24	0.7 - 1.5	<p>Bandoliered contacts</p>
				0.14 - 0.56	26 - 20	0.8 - 2.0	
				0.5 - 1.5	20 - 16	1.6 - 2.8	
				3.5 + 0.5 mm of insulation is stripped from the wires to be crimped			<p>Individual contacts</p>
				For the fabrication in line with the specification please use exclusively crimp tools approved by HARTING (see DIN EN 60352-2)			
				Insertion, removal and crimping tools see chapter 30			

¹⁾ Packaging unit 1,000 pieces

Number of contacts

max. 24

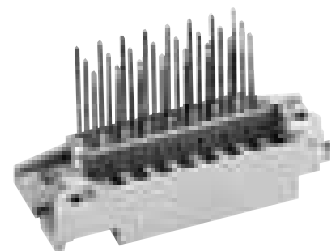

Interface connector U

Identification	Number of contacts	Part No.	Drawing	Dimensions in mm
Interface connector U with wrap posts 1 x 1 mm	24	Performance level 1 acc. to IEC 60 603-2 09 26 024 2981 ¹⁾	<p>Technical drawing showing contact arrangement and dimensions for the connector.</p>	<p>Technical drawing showing dimensions in mm for the connector.</p> <p>Contact arrangement View from termination side</p>
Mounting example			<p>Technical drawing showing mounting example on a PCB.</p>	<p>Technical drawing showing mounting example on a PCB with dimensions.</p> <p>M 3 x 8 DIN EN ISO 1207</p>

DIN Power
up to 6 A

¹⁾ Railway classification NFF 16-101, Smoke index: F1, Flammability class: I2

Number of contacts

max. 24

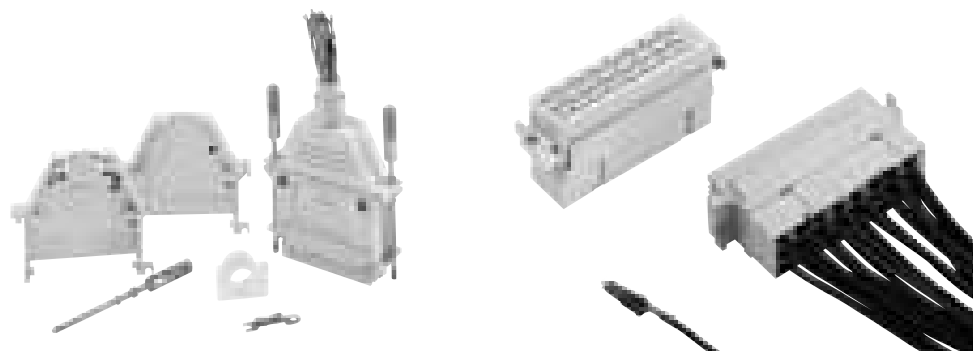

Female connectors

DIN Power up to 6 A

Identification	Number of contacts	Part No.	Drawing	Dimensions in mm
<p>Female connector for crimp contacts</p> <p>Order contacts separately see page 03.31</p>	24	09 26 024 3201 ¹⁾		
<p>Shell housing A with integrated fixing screws</p> <p>Supplied with: Shell 2x Locking screw 2x Screw M3x10 2x Nut M3 2x Screw BZ 2.9x9.5 2x Cable clamp 1x Tension relief 1x</p>		09 26 024 0401 ¹⁾		
<p>Open hood</p> <p>Supplied with: Open hood 1x Locking screw 2x Screw BZ 2.2x9.5 2x Cable tie 1x</p>		09 26 000 9901 ¹⁾	<p style="font-size: small;">2 x BZ 2.2 x 9.5 DIN ISO 1481</p>	

¹⁾ Railway classification NFF 16-101, Smoke index: F1, Flammability class: I2



Types H, H15, H16, H3, MH 24 + 7, MH 21 + 5

Page

Technical characteristics type H

04.10

Type H15 connectors



04.11

Type H16 connectors



04.16

Type H3 connectors



04.17

Technical characteristics type MH

04.20

Type MH 24 + 7 connectors

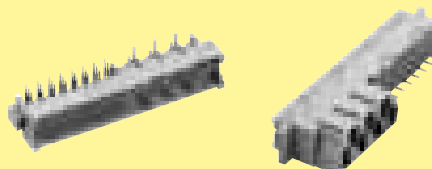

04.22

Type MH 21 + 5 connectors

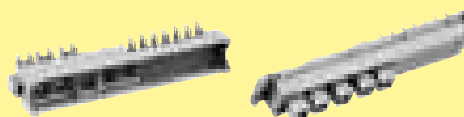

04.24

DIN Power
up to 15 A



Number of contacts
 15, 16
 14 + 1 leading contact
 (position z 32)
 13 + 2 leading contacts
 (position z 4 und z 32)
 3

Working current
 see current carrying capacity chart
 15 A max.

Clearance
 Type H15: ≥ 4.5 mm
 Type H3: ≥ 4.0 mm

Creepage
 Type H15: ≥ 8.0 mm
 Type H3: ≥ 3.7 mm

Working voltage
 The working voltage also depends on the clearance and creepage dimensions of the pcb itself and the associated wiring
 according to the safety regulations of the equipment
 Explanations see chapter 00
 Connectors should not be mated under voltage

Test voltage $U_{r.m.s.}$
 Type H15: ≥ 3.1 kV
 Type H3: ≥ 2.5 kV

Contact resistance
 ≤ 8 m Ω

Insulation resistance
 $\geq 10^{12}$ Ω for standard articles
 $\geq 10^{11}$ Ω for special NFF articles
 (with part-no. ending 222)

Temperature range
 - 55 °C ... + 125 °C
 The higher temperature limit includes the local ambient and heating effects of the contacts under load

Electrical termination
 Connector with faston
 6.3 x 2.5 (faston blade width x wire gauge)
 according to DIN 46 245 and DIN 46 247
 Solder pins for pcb connections $\varnothing 1.6 \pm 0.1$ mm
 DIN EN 60 097
 Cage clamp terminal
 0.14-1.5 mm²

Insertion and withdrawal force
 Type H15: ≤ 90 N
 Type H3: ≤ 20 N

Materials
 Mouldings
 Thermoplastic resin, glass-fibre filled, UL 94-V0
 Contacts
 Copper alloy

Contact surface
 Contact zone
 Hard silver plated or gold plated

Mating conditions see chapter 00
 Coding systems see chapter 00

Current carrying capacity

The current carrying capacity is limited by maximum temperature of materials for inserts and contacts including terminals. The current capacity curve is valid for continuous, non interrupted current loaded contacts of connectors when simultaneous power on all contacts is given, without exceeding the maximum temperature.

Control and test procedures according to DIN IEC 60 512

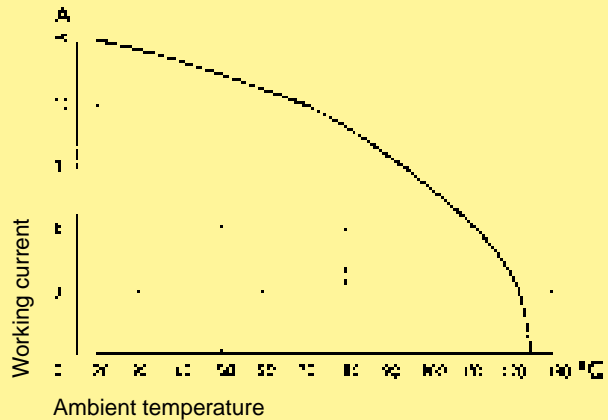

Low currents and voltages

Type H standard contacts have a silver plated surface. This precious metal has excellent conductive properties. In the course of a contact's lifetime, the silver surface generates a black oxide layer due to its affinity to sulphur. This layer is smooth and very thin and is partly interrupted when the contacts are mated and unmated, thus guaranteeing very low contact resistances. In the case of very low currents or voltages small changes to the transmitted signal may be encountered. This is illustrated below where an artificially aged contact representing a twenty year life is compared with a new contact.

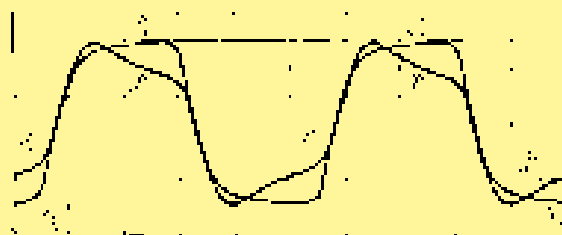

Changes to the transmitted signal after artificial ageing
 ① new contact ② after ageing

In systems where such a change to the transmitted signal could lead to faulty functions and also in extremely aggressive environments, HARTING recommend the use of gold plated contacts.

Below is a table derived from actual experiences.

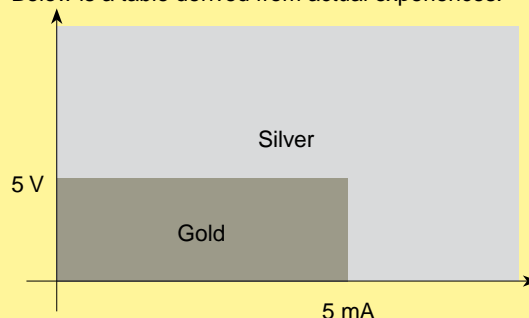

Recommendation

DIN Power up to 15 A

Number of contacts

15

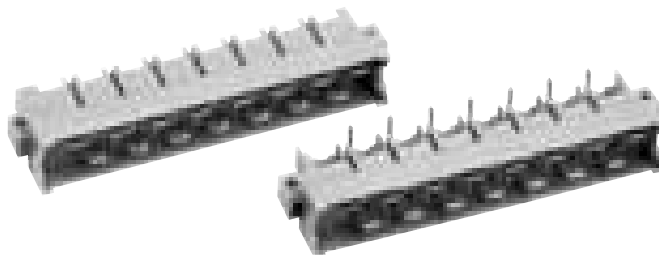

Male connectors

Identification	Number of contacts	Part No.	Drawing	Dimensions in mm
Male connector for faston 6.3 x 2.5	15	Performance level 1 acc. to IEC 60603-2 09 06 015 2912 ¹⁾	<p>Contact arrangement View from termination side</p> <p>Board drillings</p>	
1 leading contact (position z 32)	14 + 1	09 06 015 2931 ¹⁾		
2 leading contacts (position z 4 + z 32)	13 + 2	09 06 015 2922 ¹⁾		
Male connector with angled solder pins ³⁾	15	09 06 115 2911 ¹⁾ 09 06 115 2911 222 ¹⁾	<p>Contact arrangement View from termination side</p> <p>Board drillings</p>	
1 leading contact (position z 32)	14 + 1	09 06 115 2932 ¹⁾ 09 06 115 2932 222 ¹⁾		
2 leading contacts (position z 4 + z 32)	13 + 2	09 06 115 2921 ¹⁾ 09 06 115 2991 ²⁾		
Male connector with straight solder pins	15	09 06 015 2913 ¹⁾	<p>Contact arrangement View from termination side</p> <p>Board drillings</p>	
1 leading contact (position z 32)	14 + 1	09 06 015 2914 ¹⁾		

DIN Power up to 15 A

¹⁾ Variant with silver plated contacts
²⁾ Variant with gold plated contacts
³⁾ With shroud coding, see chapter 00

¹⁾ Railway classification NFF 16-101, Smoke index: F1, Flammability class: I2

Number of contacts

15

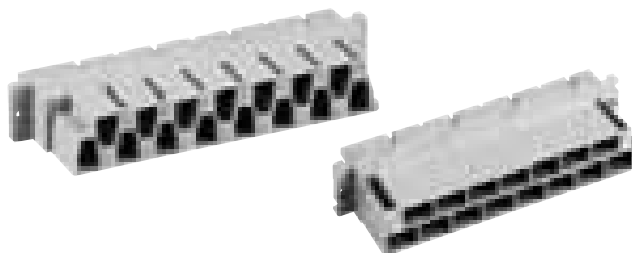

Female connectors

Identification	Number of contacts	Part No.	Drawing	Dimensions in mm
Female connector for faston 6.3 x 2.5 ¹⁾ Cannot be used in a shell housing	15	Performance level 1 acc. to IEC 60603-2 09 06 215 2811	<p>Contact arrangement View from termination side</p>	
Female connector for faston 6.3 x 2.5 ¹⁾ May be used in a shell housing	15 15	09 06 215 2871 09 06 215 2871 222 ²⁾	<p>Contact arrangement View from termination side</p> <p>Shell housing see chapter 20</p>	
Panel cut out				

DIN Power up to 15 A

¹⁾ With shroud coding, see chapter 00

²⁾ Railway classification NFF 16-101, Smoke index: F1, Flammability class: I2

Number of contacts

15

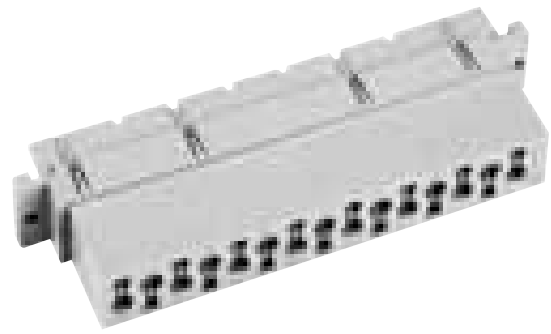

Female connectors

Identification	Number of contacts	Part No.	Drawing	Dimensions in mm
<p>Female connector with cage clamp May be used in a shell housing</p>	15	<p>Performance level 1 acc. to IEC 60 603-2</p> <p>09 06 015 2813⁰⁾</p>	<p>Contact arrangement View from termination side Slot for screw driver</p> <p>Shell housing see chapter 20</p>	
<p>Panel cut out</p>				
<p>Termination instructions</p>			<p>Screw driver width: 2.5 x 0.4 mm Stripping length: 4 - 10 mm Wire gauge: 0.14 - 1.5 mm² (AWG 26 - 16)</p>	

DIN Power up to 15 A

⁰⁾ Railway classification NFF 16-101, Smoke index: F1, Flammability class: I2

Number of contacts

15

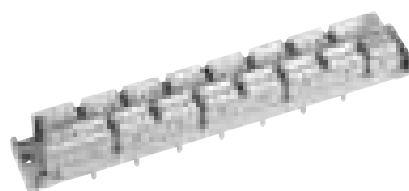

Female connectors

Identification	Number of contacts	Part No.	Drawing	Dimensions in mm
----------------	--------------------	----------	---------	------------------

Female connector
"low profile"
with solder pins³⁾

Performance level 1
acc. to IEC 60 603-2

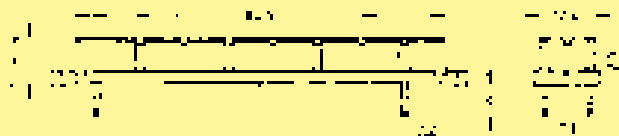

2.7 mm

15

09 06 215 2812¹⁾

4 mm

15

09 06 215 2821¹⁾
09 06 215 2821 222^{1) f)}
09 06 215 2892²⁾
09 06 215 2892 222^{2) f)}



5.5 mm

15

09 06 215 2890²⁾

7 mm

15

09 06 215 2831¹⁾
09 06 215 2891²⁾

a
2.7
4
5.5
7
10

10 mm

15

09 06 215 2841¹⁾

Contact arrangement View from termination side

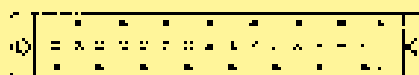

Board drillings
Mounting side

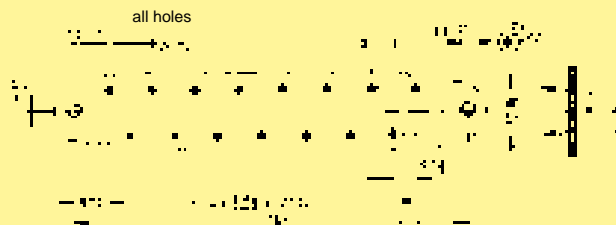

DIN Power
up to 15 A

¹⁾ Variant with silver plated contacts
²⁾ Variant with gold plated contacts
³⁾ With shroud coding, see chapter 00

^{f)} Railway classification NFF 16-101, Smoke index: F1, Flammability class: I2

Number of contacts

15

available
Q3 / 2012

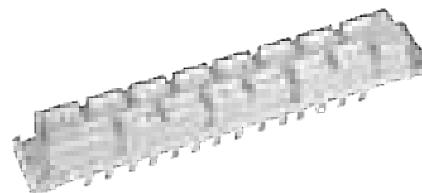

Female connectors

Identification	Number of contacts	Part No.	Drawing	Dimensions in mm
<p>Female connector "low profile" with press-in pins 3.6 mm</p> <p>Position separation termination side 5.08 mm</p>	15	<p>Performance level 1 acc. to IEC 60603-2</p> <p>09 06 215 2854 09 06 215 2854 222¹⁾</p>		
<p>Board drillings Mounting side</p>				

DIN Power
up to 15 A



¹⁾ Railway classification NFF 16-101, Smoke index: F1, Flammability class: I2

Number of contacts

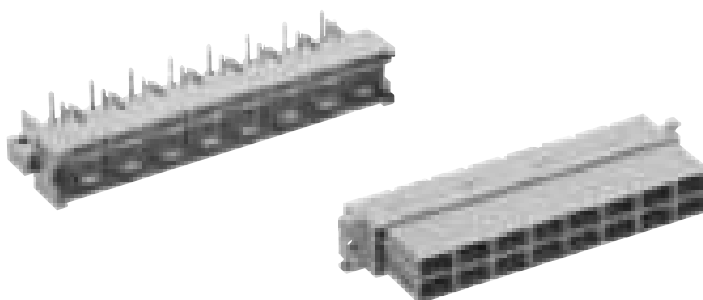
16

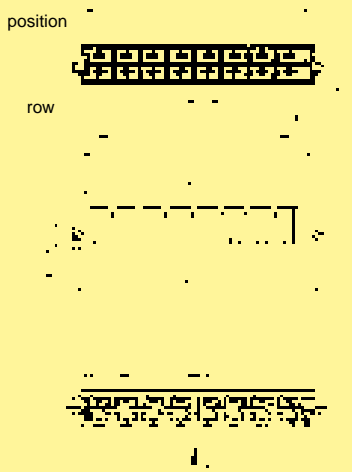

Male connectors

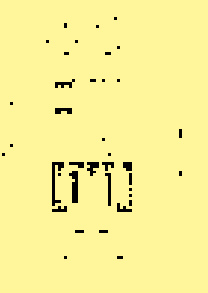
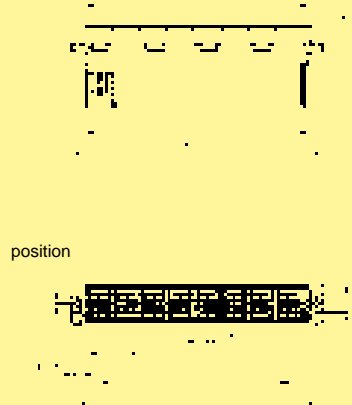
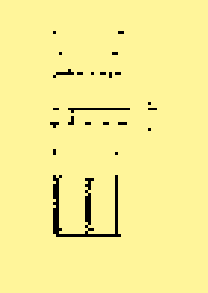
Identification	Number of contacts	Part No.	Drawing	Dimensions in mm
Male connector with angled solder pins	16	09 06 116 2511	position  row Board drillings position  all holes row	
Female connector for faston 6.3 x 2.5	16	09 06 216 2411	position  row	

DIN Power up to 15 A

Number of contacts

3

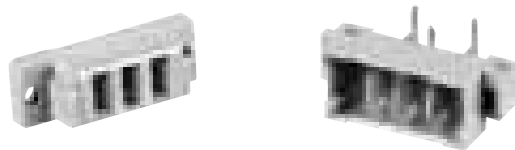

Male and female connectors

Identification	Number of contacts	Part No.	Drawing	Dimensions in mm
Male connector with angled solder pins and preleading middle contact	3	Performance level 1 acc. to IEC 60603-2 09 06 203 2911	<p>Board drillings</p>	
Female connector with solder pins	3	09 06 203 2811	<p>Board drillings</p>	

DIN Power up to 15 A



ELECTRONIC SECTION

Number of contacts	21, 24 + 7
Contact spacing (mm)	
Male connector	2.54 x 5.08
Female connector	5.08
Working current	6 A max.
see current carrying capacity chart	
Clearance	≥ 1.6 mm
Creepage	≥ 3 mm
Working voltage	
The working voltage also depends on the clearance and creepage dimensions on the pcb itself, and the associated wiring	according to the safety regulations of the equipment. Explanations see chapter 00
Test voltage $U_{r.m.s.}$	1.55 kV
Contact resistance	≤ 15 mΩ wrap, solder termination ≤ 20 mΩ including crimp connection

Electrical termination	Solder pins for pcb connection Ø 1 ± 0.1 mm acc. to IEC 60 326-3 Wrap posts 1 x 1 mm diagonal 1.34-1.45 mm Crimp terminal 0.09-1.5 mm ²
------------------------	---

Contact surface	
Contact zone	Selectively plated according to performance level ¹⁾

HEAVY DUTY SECTION*	
Number of contacts	7

Working current	15 A max.
see current carrying capacity chart	
Clearance	≥ 4.5 mm
Creepage	≥ 8.0 mm
Working voltage	
The working voltage also depends on the clearance and creepage dimensions on the pcb itself, and the associated wiring	according to the safety regulations of the equipment. Explanations see chapter 00
Test voltage $U_{r.m.s.}$	3.1 kV
Contact resistance	≤ 8 mΩ

Electrical termination	Connector for faston 6.3 x 2.5 (faston width x wire gauge) acc. to DIN 46 245 and DIN 46 247 Solder pins for pcb connection Ø 1.6± 0.1 mm acc. to DIN EN 60 097
------------------------	---

Contact surface	
Contact zone	Hard silver plated

BOTH PARTS	
Insulation resistance	≥ 10 ¹² Ω for standard articles ≥ 10 ¹¹ Ω for special NFF articles (with part-no. ending 222)

Temperature range	- 55 °C ... + 125 °C
The higher temperature limit includes the local ambient and heating effects of the contacts under load	

Insertion and withdrawal force ≤ 85 N

Materials	
Mouldings	Thermoplastic resin, glass-fibre filled, UL 94-V0
Contacts	Copper alloy

Current carrying capacity

The current carrying capacity is limited by maximum temperature of materials for inserts and contacts including terminals. The current capacity curve is valid for continuous, non interrupted current loaded contacts of connectors when simultaneous power on all contacts is given, without exceeding the maximum temperature.

Control and test procedures according to DIN IEC 60 512

Electronic section

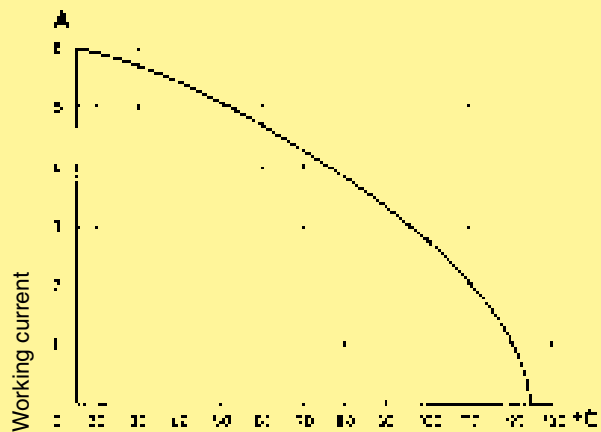

Ambient temperature

Heavy duty section

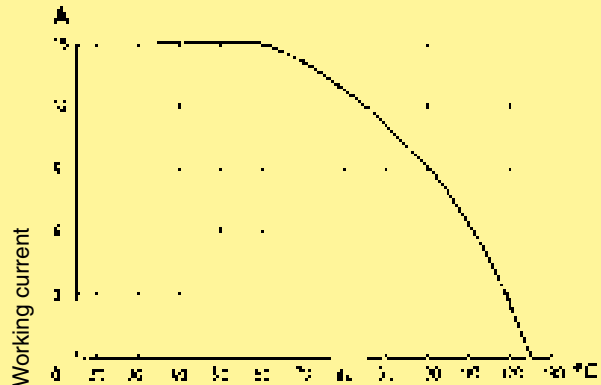

Ambient temperature

* only for type MH 24 + 7

¹⁾ Explanation of performance levels see chapter 00

Mating conditions	see chapter 00
Coding systems	see chapter 00

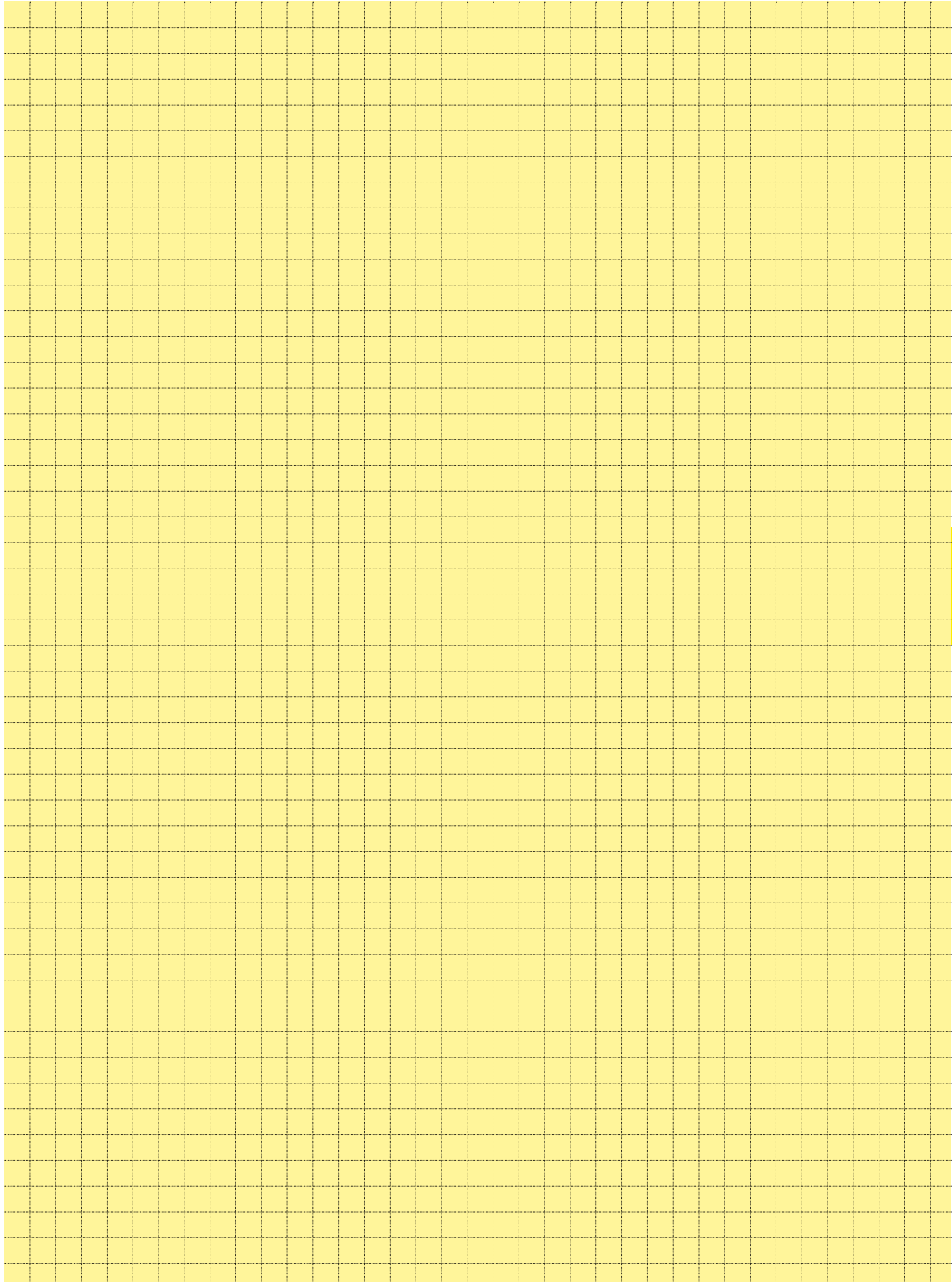

**DIN Power
up to 15 A**

Number of contacts

24 + 7
F + H

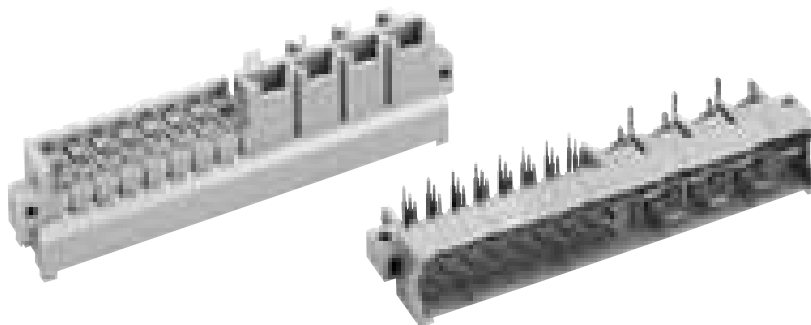

Male connectors

Identification	Number of contacts	Part No. Performance levels according to IEC 60 603-2. Explanation chapter 00		
		3	2	1
Male connector for faston 6.3 x 2.5	1 leading contact (position z 32)		09 06 031 6921 ¹⁾	09 06 031 2921 ¹⁾
	2 leading contacts (position z 2 + z 32)		09 06 031 6923 ¹⁾	
Male connector with angled solder pins ¹⁾	1 leading contact (position z 32)		09 06 131 6922	
	2 leading contacts (position z 2 + z 32)		09 06 131 6924 09 06 331 6924 ^{b)}	
	Faston terminal	Angled solder pins		
Board drillings Mounting side			Contact arrangement View from termination side	

DIN Power up to 15 A

¹⁾ With shroud coding, see chapter 00
^{b)} Connector with fixing clip see chapter 00
¹⁾ Railway classification NFF 16-101, Smoke index: F1, Flammability class: I2

Number of contacts

24 + 7
F + H

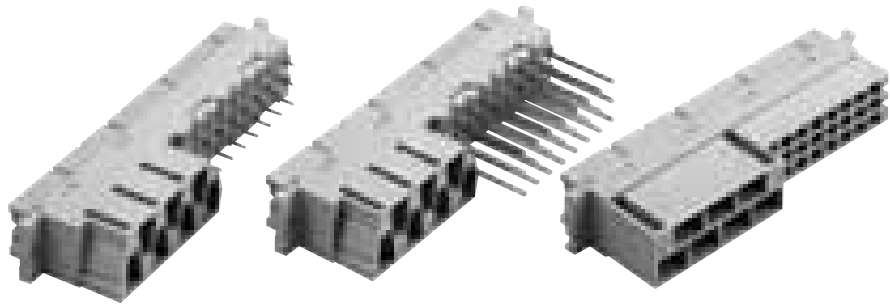

Female connectors

Identification	Number of contacts	Part No. Performance levels according to IEC 60603-2. Explanation chapter 00		
		3	2	1
Female connector with solder pins 4.5 mm ¹⁾	24 + 7		09 06 231 6822 09 06 231 6822 222 ²⁾	09 06 231 2822
Female connector with wrap posts 1 x 1 mm ¹⁾	24 + 7		09 06 231 6821	09 06 231 2821 09 06 231 2821 222 ²⁾
Female connector for crimp contacts ¹⁾ Order contacts separately, see chapter 03	24 + 7			09 06 231 2881 09 06 231 2881 222 ²⁾

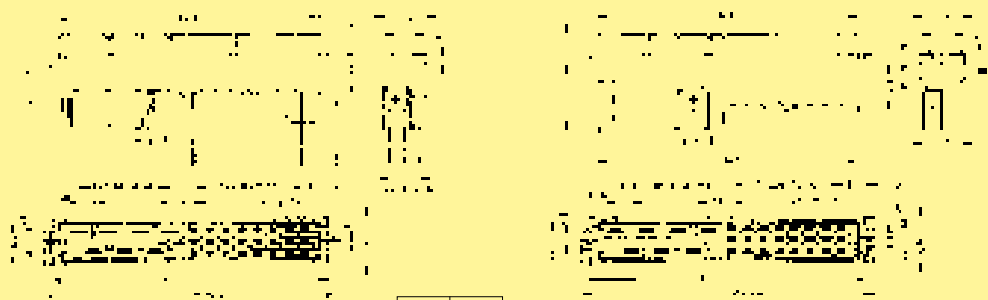

a	b
4.5	□ 0.6
22	□ 1

Panel cut out

Contact arrangement
View from termination side

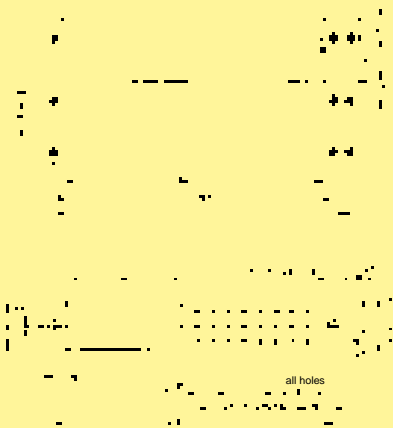

Board drillings
Mounting side

Shell housing for female connector with crimp contacts
see chapter 20

Dimensions in mm

DIN Power
up to 15 A

¹⁾ With shroud coding, see chapter 00

²⁾ Railway classification NFF 16-101, Smoke index: F1, Flammability class: I2



Number of contacts

21 + 5
F + M

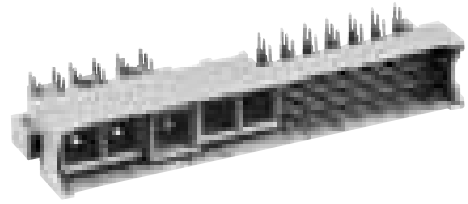

Male connectors

Identification	Number of contacts	Part No. Performance levels according to IEC 60603-2. Explanation chapter 00		
		3	2	1
Male connector with angled solder pins (without special contacts)*	21 + 5	Performance level 3 on request	09 06 121 6981	Performance level 1 on request
High current contact for printed circuit terminations max. 40 A ²⁾			09 03 000 6127	
leading contact max. 40 A ²⁾			09 03 000 6128	
Removal tool			09 99 000 0328	

Dimensions

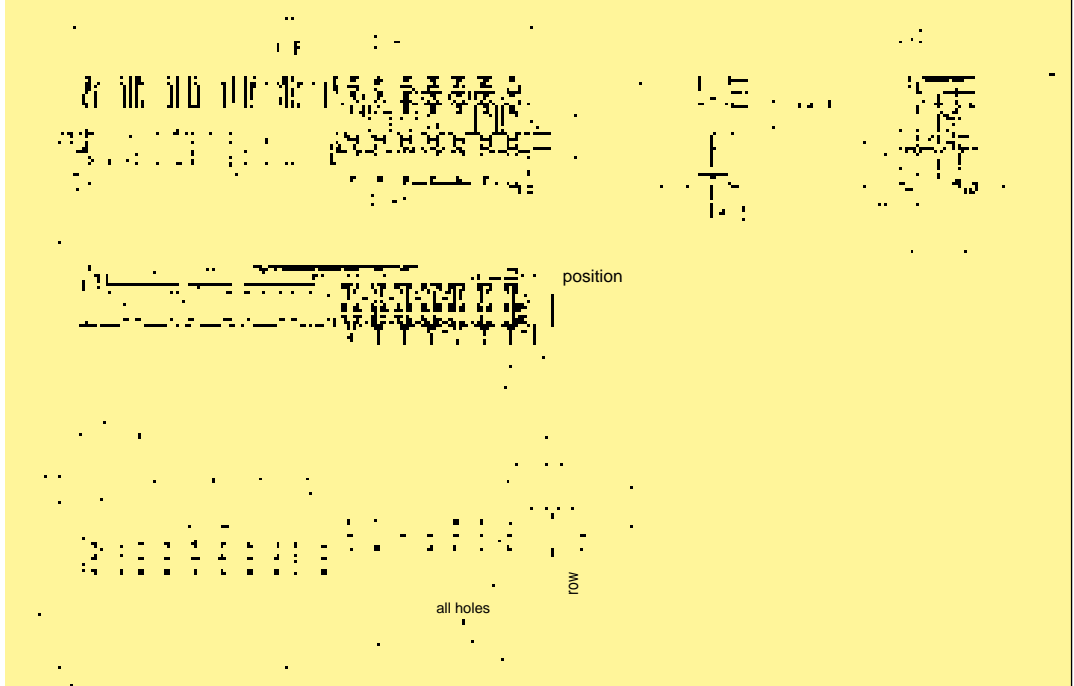

Board drillings

Mounting side

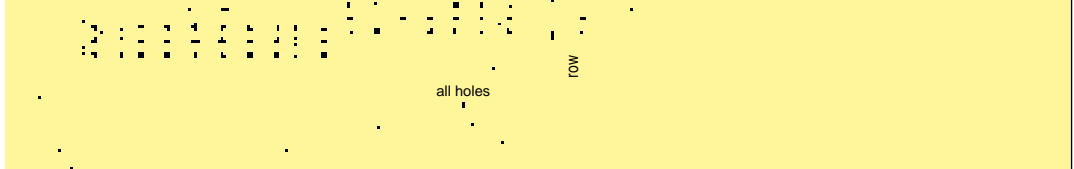

¹⁾ Leading contact in position z 32

Dimensions

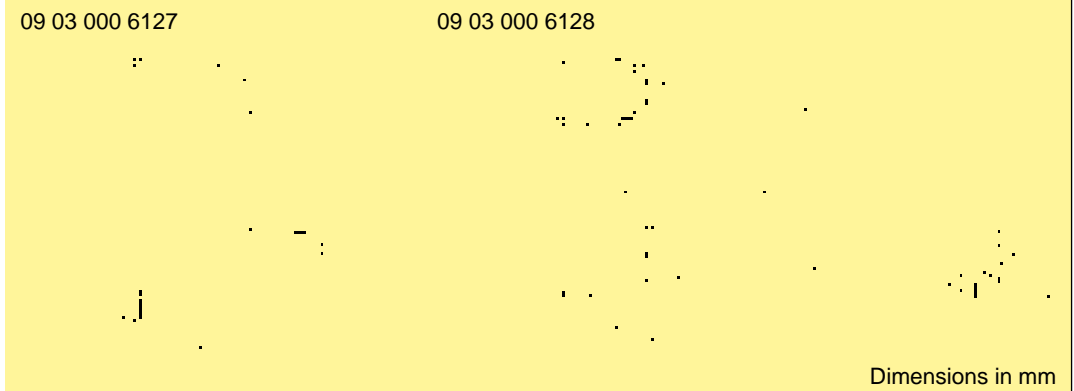

Dimensions in mm

DIN Power up to 15 A

* Pre-loaded with special contacts on request

Code keys see chapter 00

²⁾ Depending on the pcb design

Further special contacts see chapter 01

DIN 41 612 - complementary type MH



Number of contacts

21 + 5
F + M

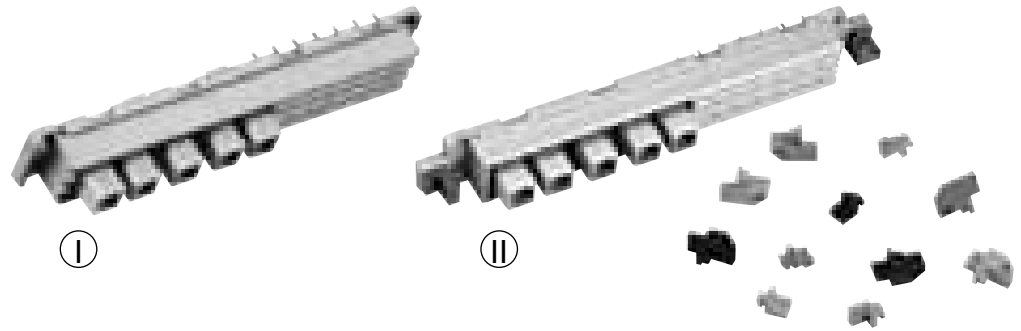

Female connectors

Identification	Number of contacts	Part No. 3	Performance levels according to IEC 60603-2. Explanation chapter 00	
			2	1
Female connector with solder pins 3.2 mm (without special contacts) without flange coding (I) with flange coding ¹⁾ (II)	21 + 5	Performance level 3 on request	09 06 221 6883	Performance level 1 on request
	21 + 5		09 06 721 6883	
High current contact Crimp contacts for printed circuit termination 20 A			09 03 000 6220	

Dimensions

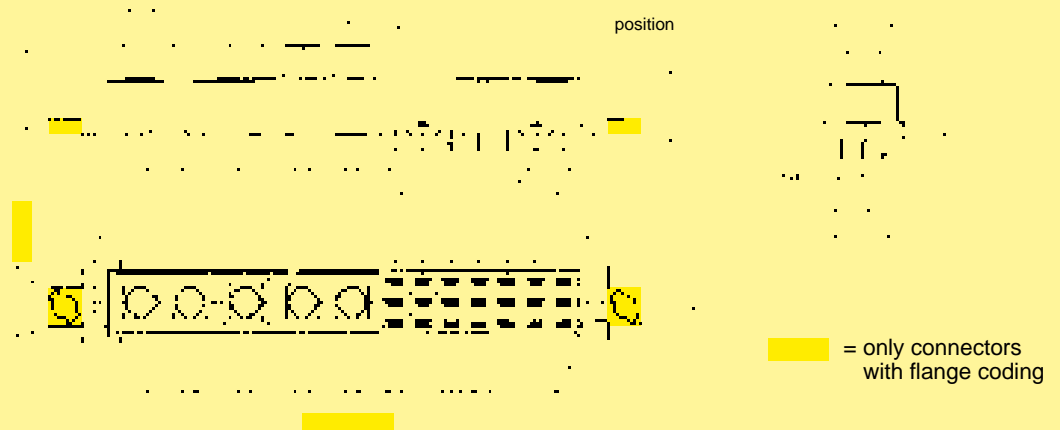

Board drillings Mounting side

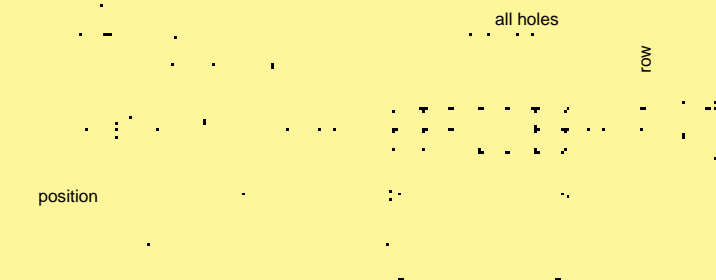

Dimensions

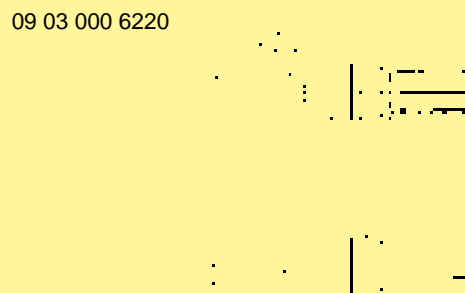

Dimensions in mm

DIN Power
up to 15 A

04
25

¹⁾ Code keys see chapter 00
Removal tool for contacts is available with part number 09 99 000 0174

Further special contacts see chapter 01

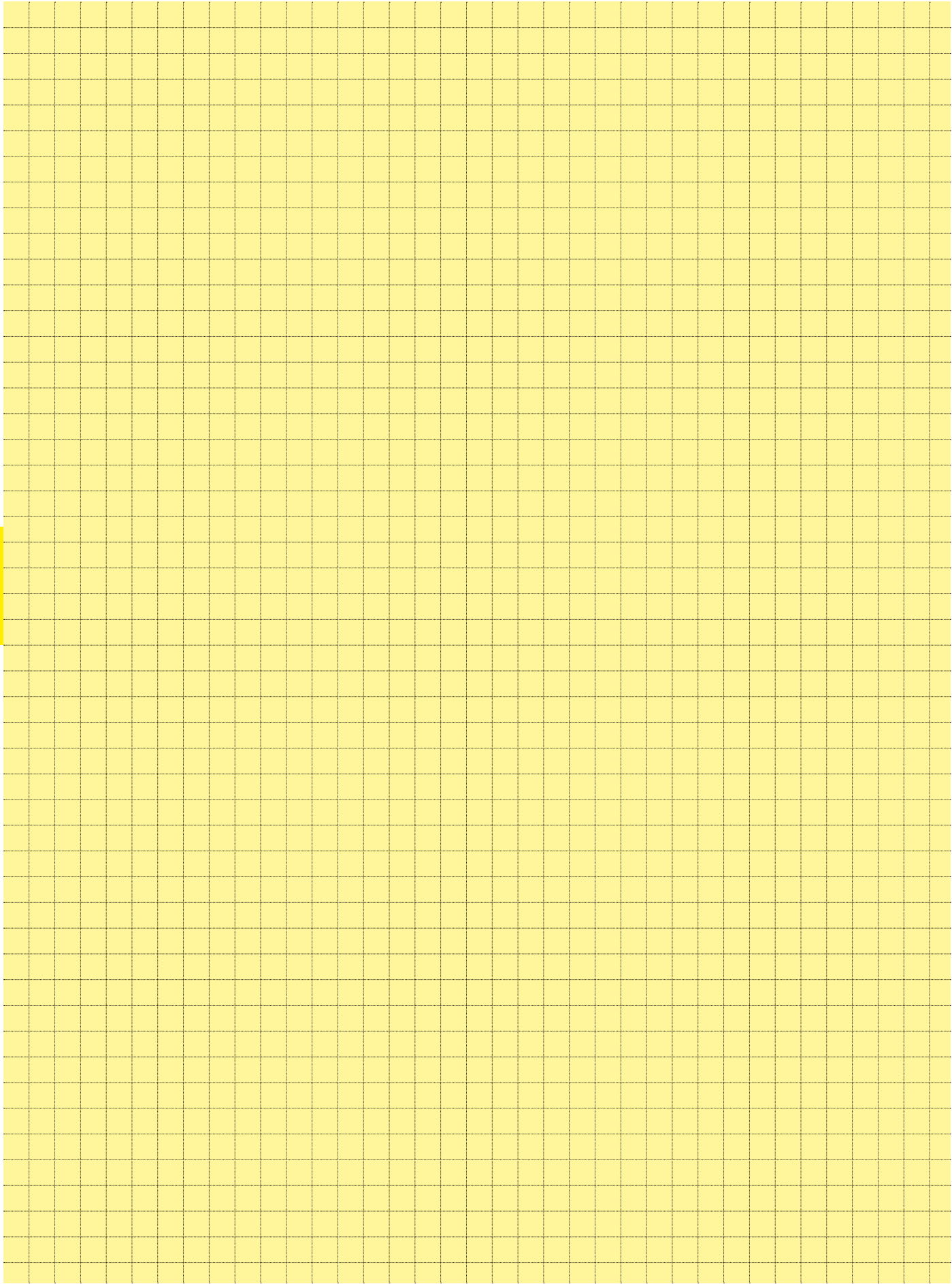



**DIN Power
up to 15 A**

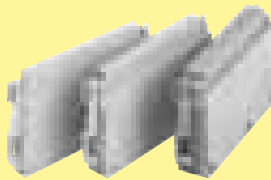

Shell housings

Page

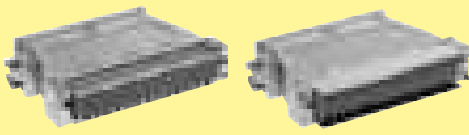
Summary of shell housings and accessories		20.02
Shell housing C		20.04
Shell housing 2C, 3C		20.08
Shell housing A		20.10
Shell housing B		20.12
Shell housing D 15		20.16
Open hood G		20.19
Junction element O		20.19
Shell housings D 20/2 and D 20/4		20.20
EMC housing		20.26
Shell housings D 20/2 and D 20/4 metallised.		20.27
Shell housings D 20 metal		20.30
Electronic connectors in Heavy Duty Housings		20.32

Summary shell housings and accessories



Appropriate connectors in shell housings	Types B, C, D, E, har-bus® 64	Types 2C, 3C	Type F	Types F, H, MH	Types E, F, H, MH
Check list: How to order shell housings and accessories. The Part No. is stated.					
Shell housings	C 09 02 064 0501 09 02 064 0502 09 03 096 0501 09 05 048 0501	2C, 3C 09 23 048 0501 09 25 030 0501	A 09 06 048 0501 09 06 048 0401 09 06 048 0402	B 09 06 048 0503 09 06 048 0504 09 06 048 0505	G 09 06 000 9957
Cable insert	09 02 000 9910 09 02 000 9911			09 06 000 9914 09 06 000 9915	
Insert for LED				09 06 000 9917	
Locking lever Order 2 pieces, in some cases each with different Part Nos. for left and right hand	09 02 000 9902 09 02 000 9903	Supplied with the shell housing	Supplied with the shell housing	09 06 000 9913 09 06 000 9919	
Locking screws Order 2 sets for fixing elements with male connectors	09 02 000 9909 ■ M 2.5x16 ■ M 2.5	09 02 000 9909 ■ M 2.5x16 ■ M 2.5	■ M 2.5x12 ■ M 2.5	09 06 000 9926 ■ M 2.5x20 ■ M 2.5	Supplied with the shell housing
for interface connectors U			09 02 000 9909 ■ M 2.5x16 ■ M 2.5	09 06 000 9926 ■ M 2.5x20 ■ M 2.5	Supplied with the shell housing
for interface connectors I	09 02 000 9909 ■ M 2.5x16 ■ M 2.5		■ M 2.5x22 Supplied with the interface connector I	09 06 000 9955 ■ M 2.5x26	Supplied with the shell housing
Fixing brackets for 19" racks for male connectors	C 	C 	A 	B 	B
Multiple fixing left	09 02 000 9919	09 02 000 9919	09 06 000 9901	09 06 000 9907 09 06 000 9966	09 06 000 9907 09 06 000 9966
Multiple fixing right	09 02 000 9920	09 02 000 9920	09 06 000 9902	09 06 000 9908 09 06 000 9967	09 06 000 9908 09 06 000 9967
Single fixing left	09 02 000 9921	09 02 000 9921	09 06 000 9905	09 06 000 9909	09 06 000 9909
Single fixing right	09 02 000 9922	09 02 000 9922	09 06 000 9906	09 06 000 9910	09 06 000 9910
for female connectors				B 	
Multiple fixing left				09 06 000 9933	
Multiple fixing right				09 06 000 9933	
Fixing brackets for angled male connectors on pcb	C 	C 			
left	09 02 000 9926	09 02 000 9926			
right	09 02 000 9927	09 02 000 9927			
Fixing brackets for inverse male connectors on pcb	R 	R 			
R 1	09 02 000 9953	09 02 000 9953			
R 32	09 02 000 9954	09 02 000 9954			
Distance fixing brackets for piggyback connectors					
Type D top	09 04 000 9907				09 04 000 9907
Type E bottom	09 04 000 9906				09 04 000 9906
Type F top	09 06 000 9936				09 06 000 9936
Type F bottom	09 06 000 9937				09 06 000 9937
Protection strip for 20 mm shell housing				09 06 000 9929	
Protection and fixing strip for 20 mm shell housing				09 06 001 9909	

■ Female connectors ■ Male connectors

Detailed system description see chapter 00

Summary shell housings and accessories



Appropriate connectors in shell housings	Types F, H, MH	Types F, H, MH	Types F, H, MH	Types F, H, MH	Types F, H, MH
<p>Check list: How to order shell housings and accessories.</p> <p>The Part No. is stated.</p>					
Shell housings	<p>O</p> <p>09 06 000 9968 09 06 000 9930°</p> <p>° order 2 pieces</p>	<p>D 15</p> <p>09 06 048 0515</p>	<p>D 20</p> <p>09 06 048 0521 09 06 048 0522</p>	<p>D 20 metallised</p> <p>09 06 948 0521 09 06 948 0522</p>	<p>D 20 metal</p> <p>09 06 848 0550 09 06 848 0551</p>
Cable insert			09 06 000 9988 09 06 000 9989	09 06 900 9988	
Insert for LED			09 06 000 9986 09 06 000 9987	09 06 900 9986 09 06 900 9987	
<p>Locking lever</p> <p>Order 2 pieces, in some cases each with different Part Nos. for left and right hand</p>		Supplied with the shell housing			
<p>Locking screws</p> <p>Order 2 sets for fixing elements with male connectors</p>	<p>09 06 000 9926</p> <p>⚙ M 2.5x20 ⚙ M 2.5</p>	<p>09 06 000 9926</p> <p>⚙ M 2.5x16 ⚙ M 2.5</p>	Supplied with the shell housing	Supplied with the shell housing	Supplied with the shell housing
for interface connectors U	—	—	—	—	—
for interface connectors I	—	—	—	—	—
<p>Shroud</p> <p>for screw fixing with interface connector I</p>	—	—	09 06 001 9964	09 06 001 9964	—
<p>Fixing brackets for 19" racks for male connectors</p>	B 	B 	B 	B 	B
Multiple fixing left	09 06 000 9907 09 06 000 9966	09 06 000 9907 09 06 000 9966	09 06 000 9907 09 06 000 9966 09 06 000 9995 09 06 000 9997	09 06 900 9907 09 06 900 9966 09 06 900 9995 09 06 900 9997	09 06 900 9997
Multiple fixing right	09 06 000 9908 09 06 000 9967	09 06 000 9908 09 06 000 9967	09 06 000 9908 09 06 000 9967 09 06 000 9996 09 06 000 9998	09 06 900 9908 09 06 900 9967 09 06 900 9996	09 06 900 9996
Single fixing left	09 06 000 9909	09 06 000 9909	09 06 000 9909 09 06 001 9934	09 06 900 9909 09 06 901 9934	09 06 800 9943 09 06 901 9924
Single fixing right	09 06 000 9910	09 06 000 9910	09 06 000 9910 09 06 001 9935	09 06 900 9910 09 06 901 9935	09 06 800 9944 09 06 901 9925
for female connectors	B 	B 			
Multiple fixing left right	only ... 9930 09 06 000 9933 09 06 000 9933	09 06 000 9933 09 06 000 9933			
Protection and fixing strip for 20 mm shell housing			09 06 001 9909	09 06 901 9909	

Shell housings

Female connectors Male connectors

Detailed system description see chapter 00

Shell housing C for types B, C, D, E and har-bus® 64



- ① Shell 1x
- ② Cover 1x
- ③ Blinding plate 1x
- ④ Cable tie 1x
- ⑤ Blinding piece 2x
- ⑥ Grounding plate 1x
- ⑦ Screw BZ 2.2 x 9.5
DIN ISO 1481 2x
- ⑧ Screw
- a) BZ 2.9 x 6.5
DIN ISO 1482 3x
- b), c), d) BZ 2.9 x 13
DIN ISO 1483 3x

Round cable insert

Locking levers 2 x
Locking screws 2 x

(10 mm) 09 02 064 0501
(15 mm) 09 02 064 0502

(15 mm) 09 03 096 0501

(20 mm) 09 05 048 0501

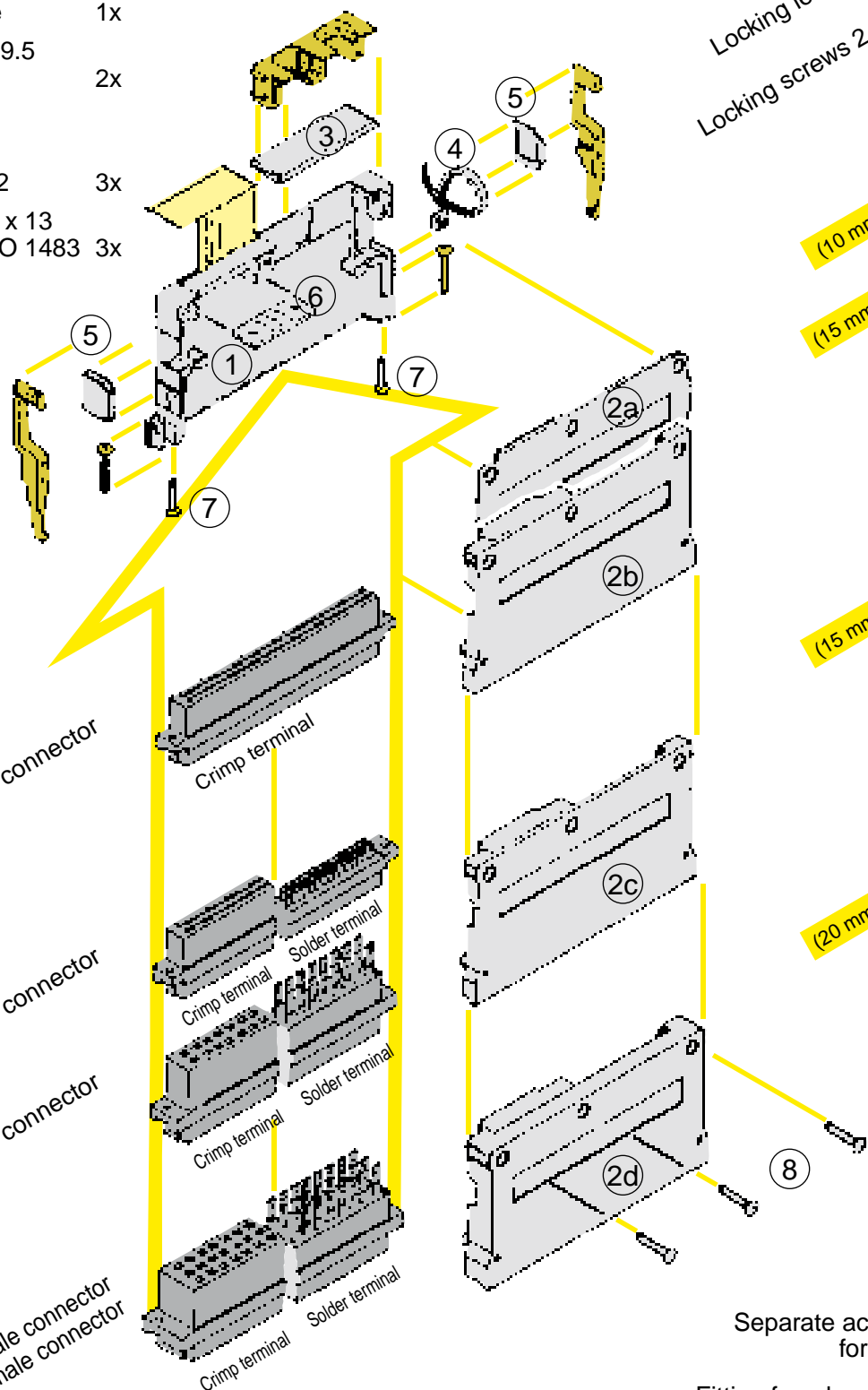

Shell housings

Type B female connector

Type C female connector

Type D female connector

Type E female connector
har-bus® 64 female connector

Crimp terminal
Crimp terminal
Crimp terminal
Crimp terminal
Solder terminal
Solder terminal
Solder terminal
Solder terminal

2a
2b
2c
2d

Separate accessories for housings
Fitting female connectors
Flat cable access
Housing parts supplied

Shell housing C for types B, C, D, E and har-bus® 64

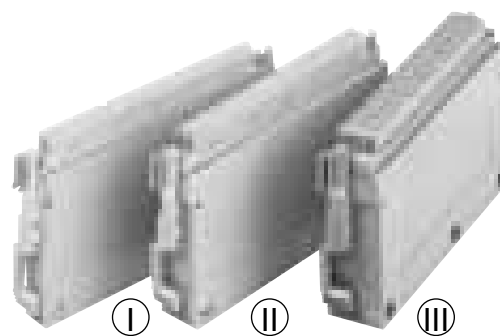

Identification	Part No.	Drawing	Dimensions in mm
Shell housing C for female connectors type B I	10 mm 09 02 064 0501		
	15 mm 09 02 064 0502		
Shell housing C for female connectors types C, D II	15 mm 09 03 096 0501		
Shell housing C for female connectors type E, har-bus® 64 III	20 mm 09 05 048 0501		

Shell housings

1) Possible access for flat cable (18 x Ø 1.27). Remove the blanking piece.

Shell housing C

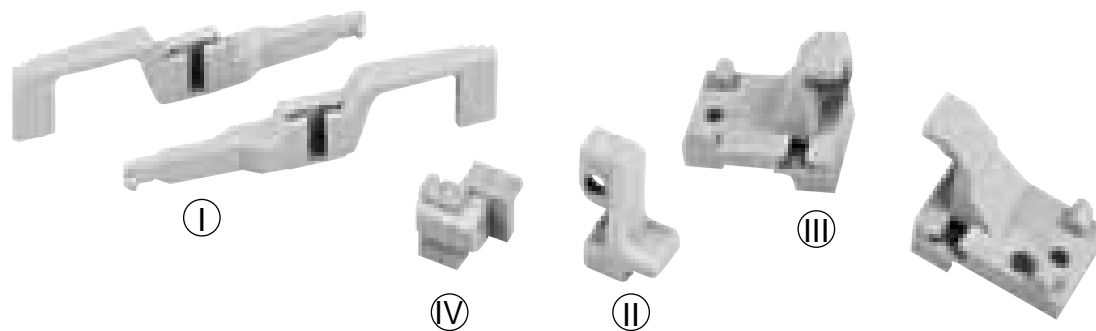

Accessories

Identification	Part No.	Drawing	Dimensions in mm
Locking lever for shell housing C I	left 09 02 000 9902 right 09 02 000 9903		
Fixing brackets C for male connectors for 19" racks according to DIN EN 60 297, part 3-101 Multiple fixing II	left 09 02 000 9919 right 09 02 000 9920		
Single fixing III	left 09 02 000 9921 right 09 02 000 9922		
Fixing brackets R for inverse male connectors on pcb's IV	R 1 09 02 000 9953 R 32 09 02 000 9954		
Screw DIN ISO 7049 M 2.2 x 9.5	09 06 001 9974		See application example 4, chapter 01

Shell housings

20
06

Shell housing C

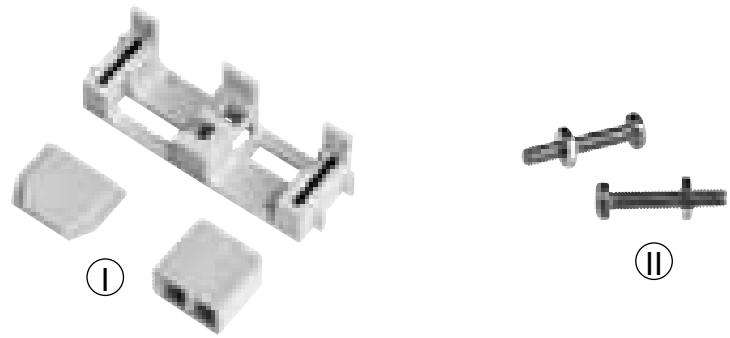

Accessories

Identification	Part No.	Drawing	Dimensions in mm
Fixing brackets C for angled male connectors on pcb without fixing possibility in 19" racks (I)	left 09 02 000 9926 ^{f)} right 09 02 000 9927 ^{f)}		
Round cable insert 2 x \varnothing 6.5 for shell housing C 09 02 064 0501 Supplied with: Round cable insert 1x Blinding piece A 1x Blinding piece B 1x Cable tie 1x	09 02 000 9910 ^{f)}		
Round cable insert 2 x \varnothing 11.5 (I)	for shell housings C 09 02 064 0502 09 03 096 0501 09 05 048 0501 Supplied with: Round cable insert 1x Blinding piece A 1x Blinding piece B 1x Cable tie 1x	09 02 000 9911 ^{f)} 	
Locking screws (II)	09 02 000 9909 ¹⁾		

Shell housings

¹⁾ Order 2 pieces for one shell housing
^{f)} Railway classification NFF 16-101, Smoke index: F1, Flammability class: I2

Shell housing 2C, 3C

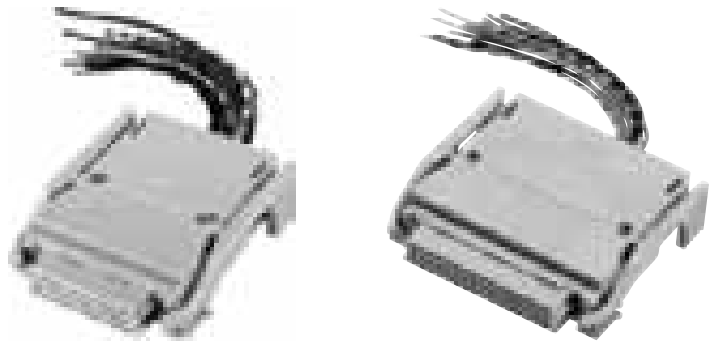

Identification

Part No.

Drawing

Dimensions in mm

Shell housing 2C
for female connectors
type 2C

09 23 048 0501

Supplied with:
Shell 1x
Cover with 2 locking
levers 1x
Cable tie 1x
Screw 2.2 x 9.5
4x (09 06 001 9974)

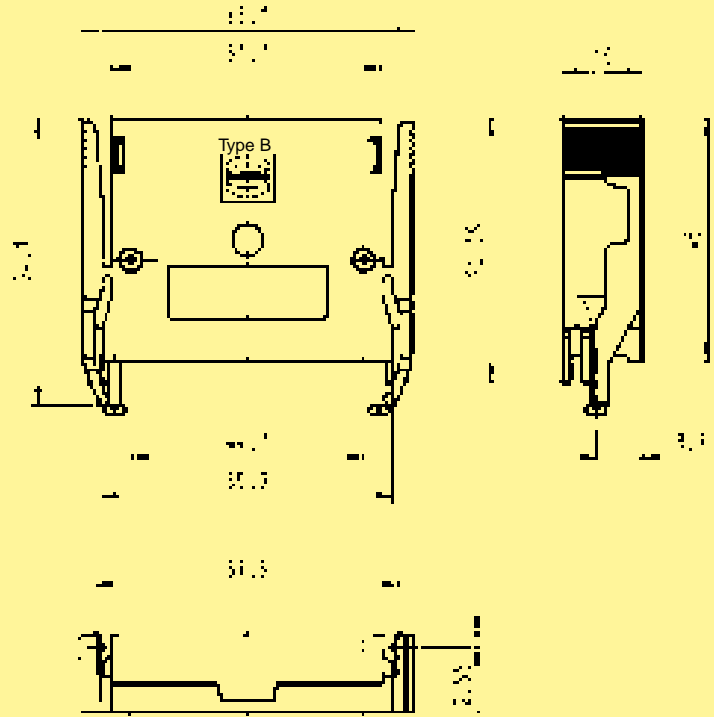

Shell housing 3C
for female connectors
type 3C

09 25 030 0501

Supplied with:
Shell 1x
Cover with 2 locking
levers 1x
Cable tie 1x
Screw 2.2 x 9.5
4x (09 06 001 9974)

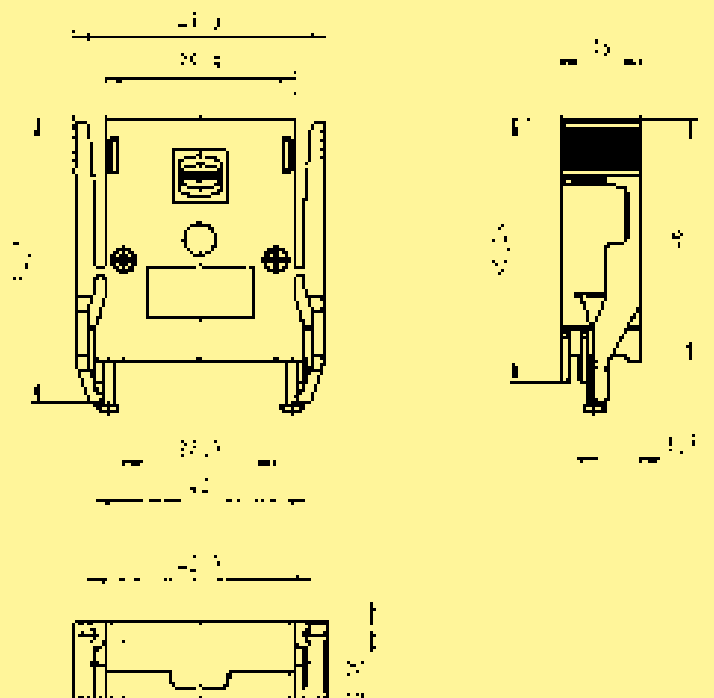

Shell
housings

Shell housing 2C, 3C

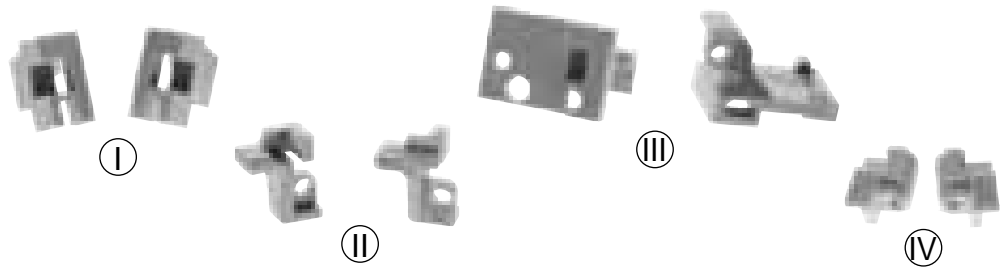

Accessories

Identification	Part No.	Drawing	Dimensions in mm									
<p>Fixing brackets C for angled male connectors on pcb without fixing possibility in 19" racks</p> <p>⓪</p>	<p>left 09 02 000 9926</p> <p>right 09 02 000 9927</p>		<table border="1"> <thead> <tr> <th></th> <th>a</th> </tr> </thead> <tbody> <tr> <td>2C</td> <td>63.7</td> </tr> <tr> <td>3C</td> <td>48.4</td> </tr> </tbody> </table>		a	2C	63.7	3C	48.4			
	a											
2C	63.7											
3C	48.4											
<p>Fixing brackets C for male connectors for 19" racks according to DIN EN 60 297, part 3-101</p> <p>Multiple fixing</p> <p>Ⓛ</p>	<p>left 09 02 000 9919</p> <p>right 09 02 000 9920</p>											
<p>Single fixing</p> <p>Ⓜ</p>	<p>left 09 02 000 9921</p> <p>right 09 02 000 9922</p>		<table border="1"> <thead> <tr> <th></th> <th>b</th> <th>c</th> </tr> </thead> <tbody> <tr> <td>2C</td> <td>82.3</td> <td>88.4</td> </tr> <tr> <td>3C</td> <td>67.1</td> <td>73.2</td> </tr> </tbody> </table>		b	c	2C	82.3	88.4	3C	67.1	73.2
	b	c										
2C	82.3	88.4										
3C	67.1	73.2										
<p>Fixing brackets R for inverse male connectors on pcb's</p> <p>Ⓝ</p>	<p>R 1 09 02 000 9953</p> <p>R 32 09 02 000 9954</p>		<table border="1"> <thead> <tr> <th></th> <th>d</th> </tr> </thead> <tbody> <tr> <td>2C</td> <td>64.1</td> </tr> <tr> <td>3C</td> <td>48.9</td> </tr> </tbody> </table>		d	2C	64.1	3C	48.9			
	d											
2C	64.1											
3C	48.9											

Shell housings

Shell housing A for type F

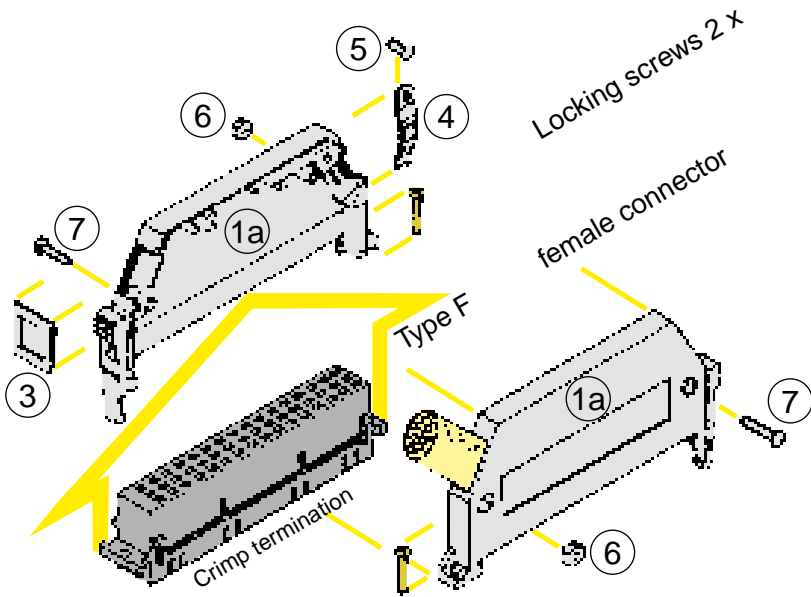

(15 mm) 09 06 048 0501

- ①a Casing shell 2x
- ③ Blinding piece 1x
- ④ Cable clamp 1x
- ⑤ Screw BZ 2.9 x 9.5 DIN ISO 1481 1x
- ⑥ Hexagonal nut M3 DIN EN ISO 4032 2x
- ⑦ Screw M3 x 12 DIN EN ISO 1207 2x

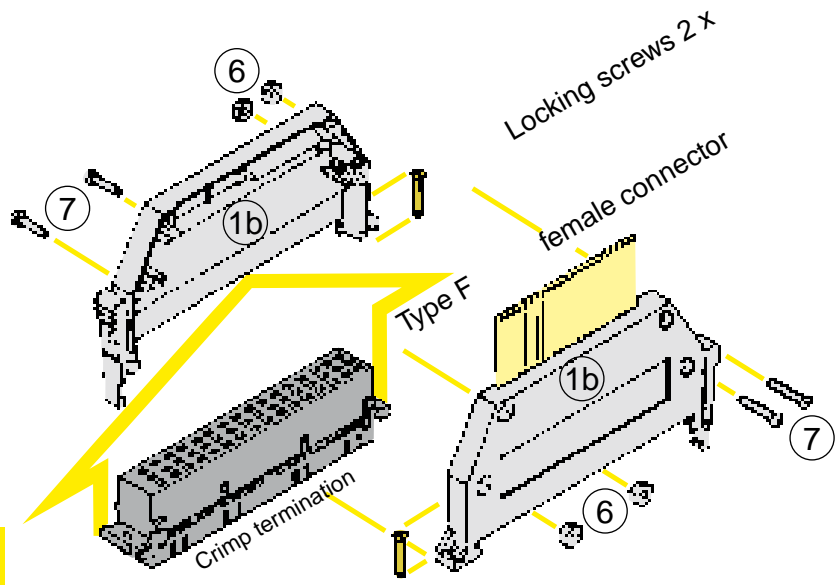

(15 mm) 09 06 048 0401

- ①b Casing shell 2x
- ⑥ Hexagonal nut M3 DIN EN ISO 4032 4x
- ⑦ Screw M3 x 12 DIN EN ISO 1207 4x

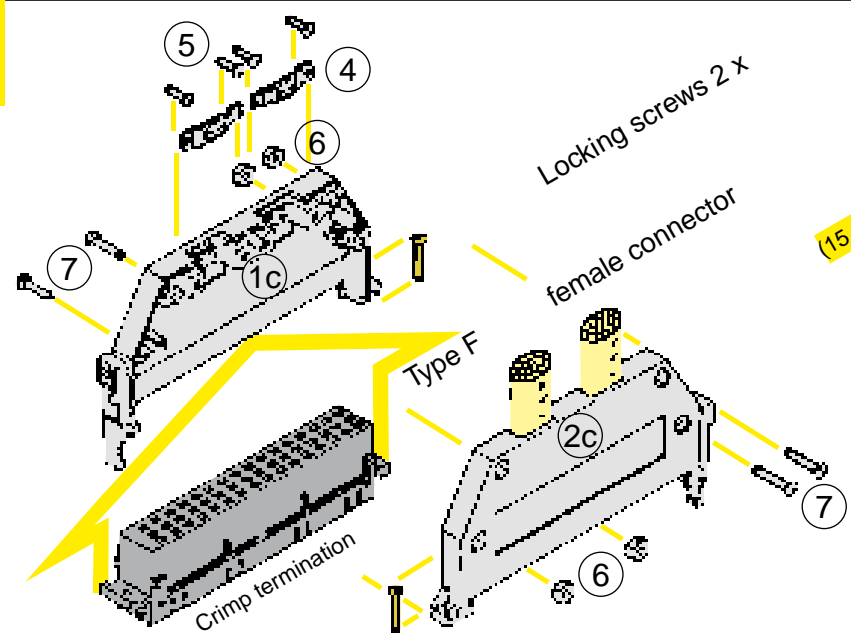

(15 mm) 09 06 048 0402

- ①c Shell 1x
- ②c Cover 1x
- ④ Cable clamp 2x
- ⑤ Screw BZ 2.9 x 9.5 DIN ISO 1481 4x
- ⑥ Hexagonal nut M3 DIN EN ISO 4032 4x
- ⑦ Screw M3 x 12 DIN EN ISO 1207 4x

- Separate accessories for housings
- Fitting female connectors
- Cable access
- Housing parts supplied

Shell housings

20
10 Moulding material: thermoplastic resin, glass-fibre filled, UL 94-V0

Shell housing A for type F

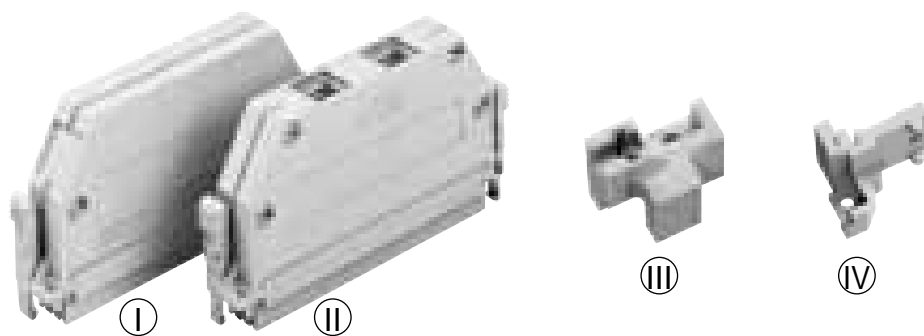

Identification	Part No.	Drawing	Dimensions in mm
Shell housing A Side entry ①	15 mm 09 06 048 0501 ^{f)}		
Flat cable entry ②	15 mm 09 06 048 0401 ^{f)}		
Top entry ③	15 mm 09 06 048 0402 ^{f)}		
Cable clamp incl. screw	09 06 001 9986	1 x ④ + 2 x ⑤ on page 20.10	
Fixing brackets A for male connectors for 19" racks according to DIN EN 60 297, part 3-101	left 09 06 000 9901 ^{f)}		
Multiple fixing ③	right 09 06 000 9902 ^{f)}		
Single fixing ④	left 09 06 000 9905 ^{f)} right 09 06 000 9906 ^{f)}		

Shell housings

^{f)} Railway classification NFF 16-101, Smoke index: F1, Flammability class: I2

Shell housing B for types F, H and MH



- ① Shell 1x
- ② Cover 1x
- ③ Blinding plate 1x
- ④ Cable clamp 2x
- ⑤ Screw BZ 2.9 x 9.5
DIN ISO 1481 4x
- ⑥ Blinding piece 2x
- ⑦ Grounding plate 1x
- ⑧ Screw
 - a) BZ 2.9 x 9.5
DIN ISO 1483 3x
 - b), c) BZ 2.9 x 13
DIN ISO 1483 3x

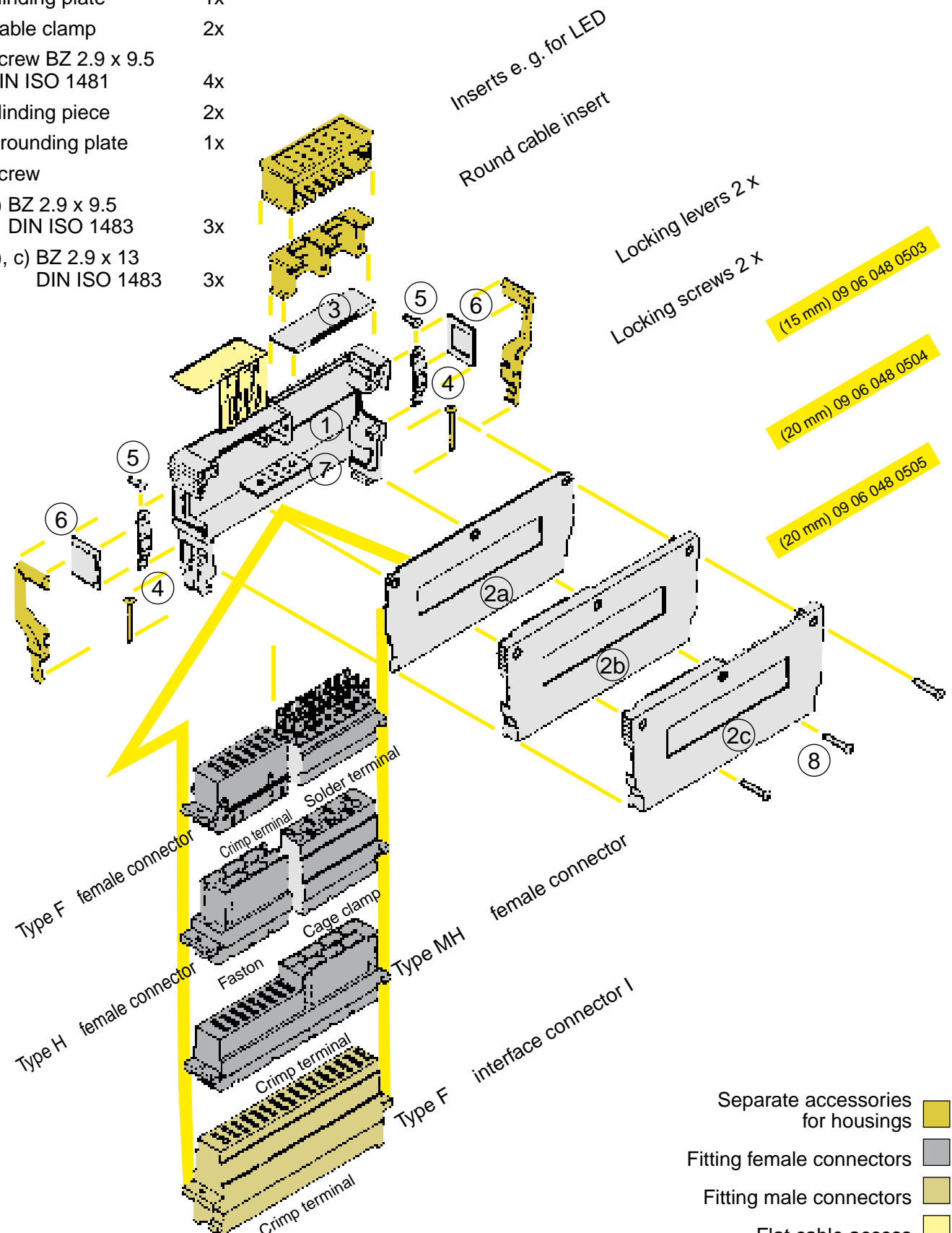

Shell housings

- Separate accessories for housings
- Fitting female connectors
- Fitting male connectors
- Flat cable access
- Housing parts supplied

Shell housing B for types F, H and MH

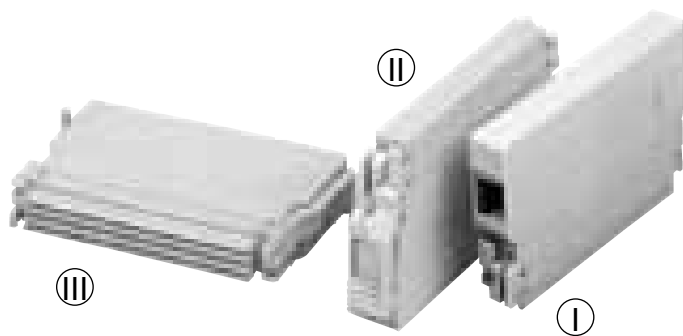

Identification

Part No.

Drawing

Dimensions in mm

Shell housing B

Ⓡ

15 mm
09 06 048 0503

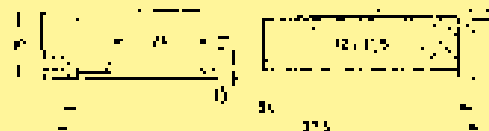

Ⓢ

20 mm
09 06 048 0504

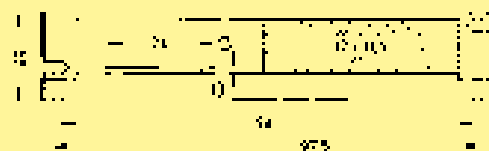

Ⓣ

20 mm
09 06 048 0505



Inserts see page 20.15

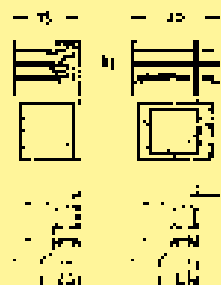
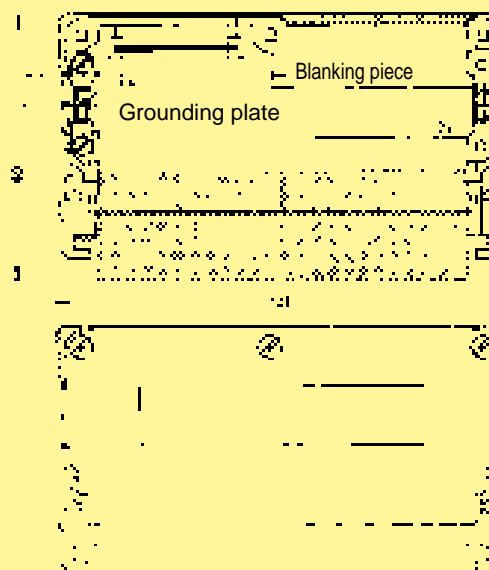

1) Possible access for flat cable (18 x ø 1.27). Remove the blanking piece

Shell housing B

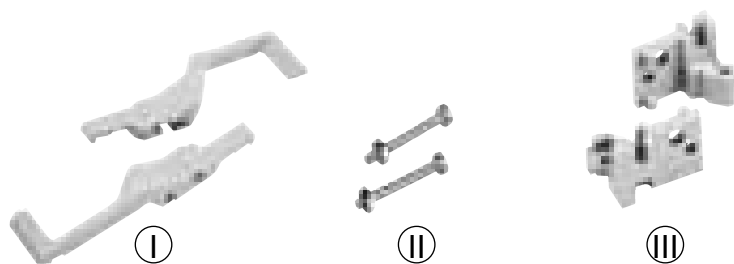

Accessories

Identification	Part No.	Drawing	Dimensions in mm
Locking lever for shell housing B 09 06 048 0503 ①	09 06 000 9913 ¹⁾		
09 06 048 0504 09 06 048 0505 left 09 06 000 9913 ¹⁾ right 09 06 000 9919 ¹⁾	left 09 06 000 9913 ¹⁾ right 09 06 000 9919 ¹⁾		
Locking screws ②	09 06 000 9926 ¹⁾		
Fixing brackets B for male connectors for 19" racks according to DIN EN 60297, part 3-101 Multiple fixing without nut ③	left 09 06 000 9907 ¹⁾ right 09 06 000 9908 ¹⁾		
with nut M 2.5 DIN 562	left 09 06 000 9966 ¹⁾ right 09 06 000 9967 ¹⁾		
Single fixing without nut ③	left 09 06 000 9909 ¹⁾ right 09 06 000 9910 ¹⁾		







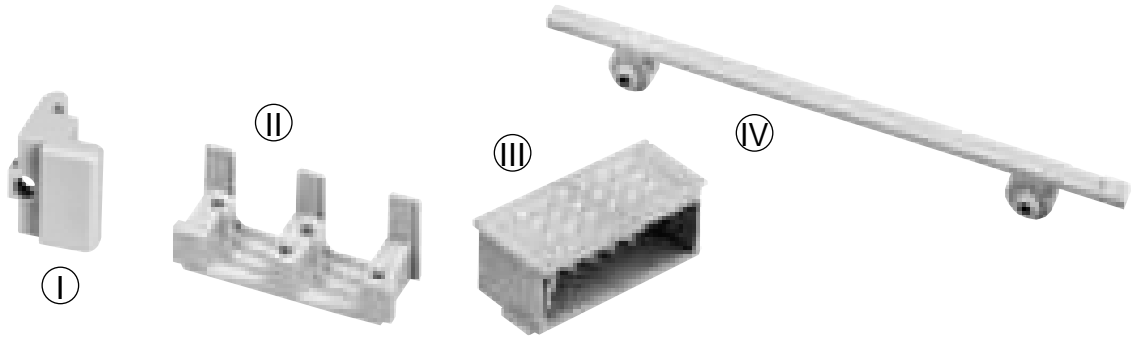

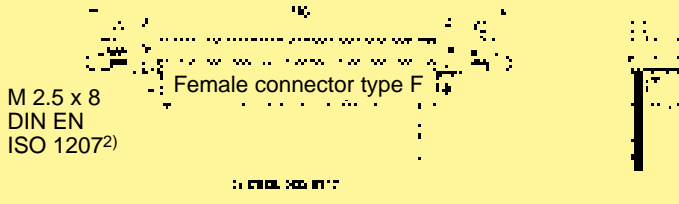

Shell housings

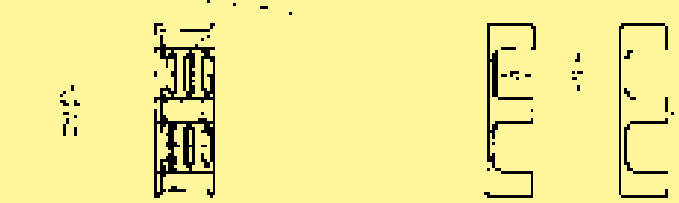
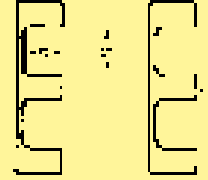
¹⁾ Railway classification NFF 16-101, Smoke index: F1, Flammability class: I2

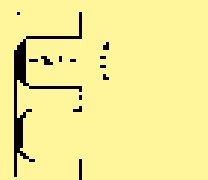
Shell housing B

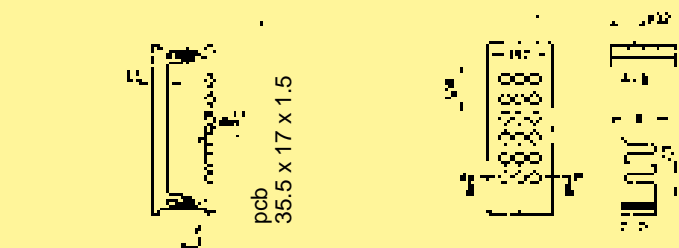
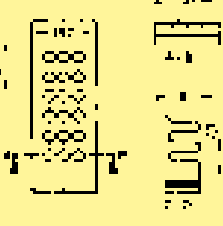

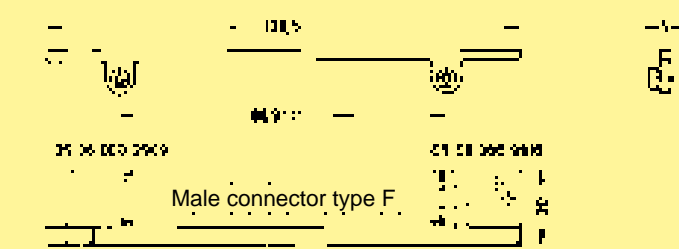
Accessories

Identification	Part No.	Drawing	Dimensions in mm
<p>Fixing brackets B for female connectors for 19" racks according to DIN EN 60297, part 3-101</p> <p>Multiple fixing </p> <p>¹⁾ Order 2 pieces for one female connector</p>	09 06 000 9933 ¹⁾	 <p>M 2.5 x 8 DIN EN ISO 1207²⁾</p> <p>Female connector type F</p> <p>²⁾ nut and screw not supplied with fixing brackets</p>	
<p>Round cable insert 2 x ø 10</p> <p>for shell housings B 09 06 048 0503 09 06 048 0504</p> <p>Supplied with: Round cable insert 1x Blinding piece 1x</p>	09 06 000 9914		
<p>Round cable insert 2 x ø 12.5</p> <p></p> <p>for shell housing B 09 06 048 0505</p> <p>Supplied with: Round cable insert 1x Blinding piece 1x</p>	09 06 000 9915		
<p>Insert for LED</p> <p></p> <p>for shell housing B 09 06 048 0505</p>	09 06 000 9917	 <p>pcb 36.5 x 17 x 1.5</p>	
<p>Protection strip</p> <p></p> <p>Used with shell housings type B for front side access 09 06 048 0504 09 06 048 0505</p>	09 06 000 9929	 <p>Male connector type F</p>	

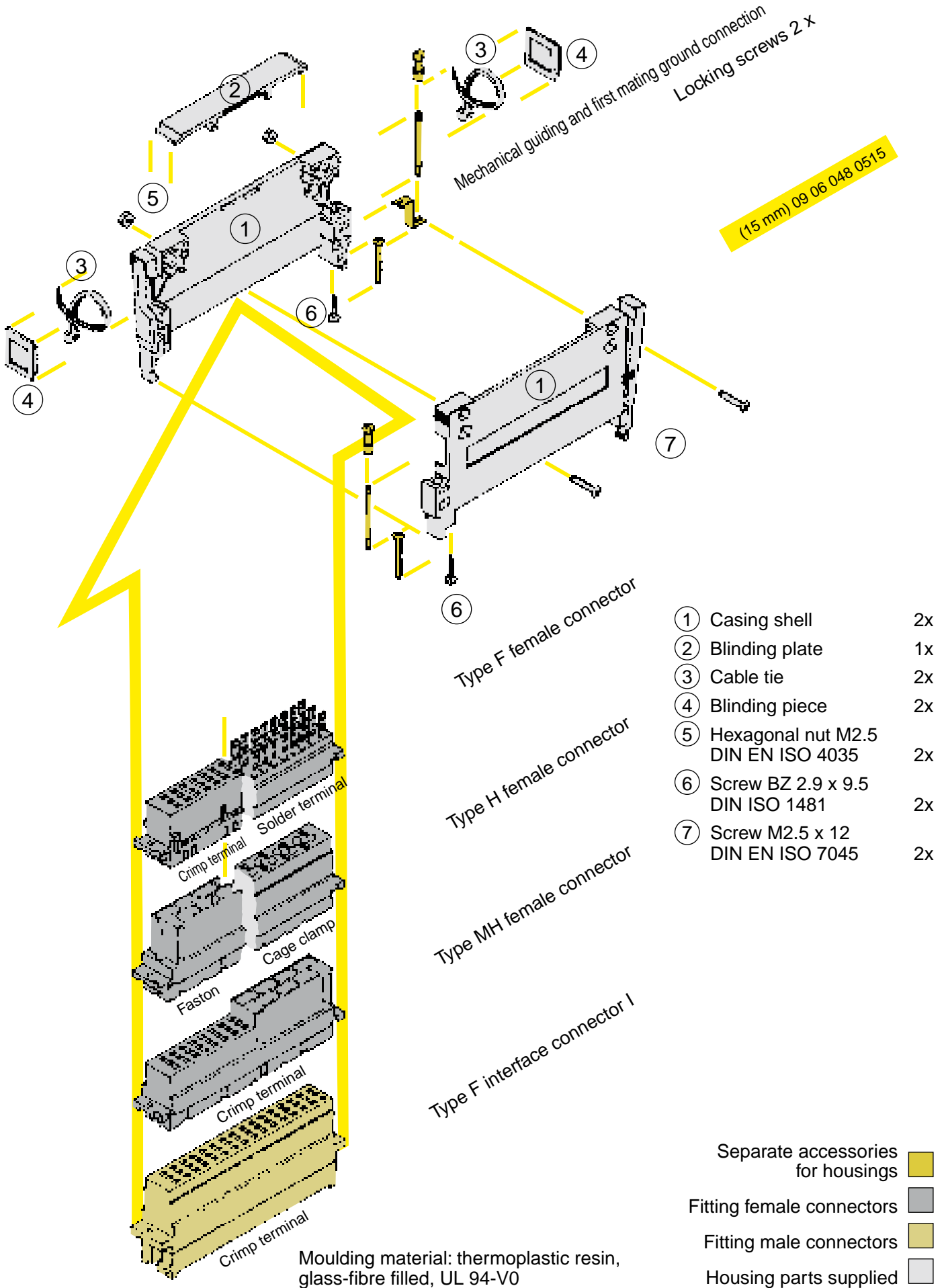

Shell housing D 15 for types F, H and MH

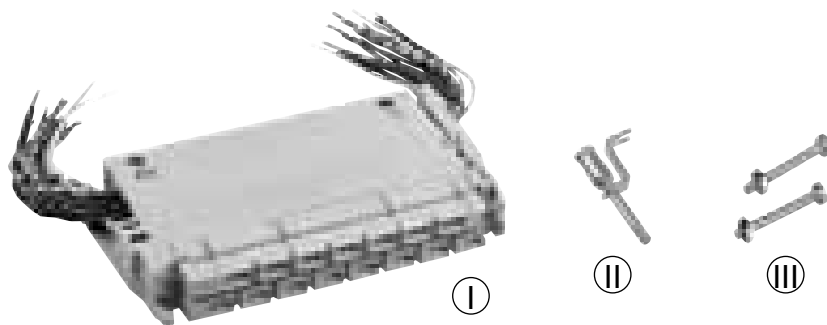

Identification

Part No.

Drawing

Dimensions in mm

Shell housing D 15

I

15 mm
09 06 048 0515¹⁾

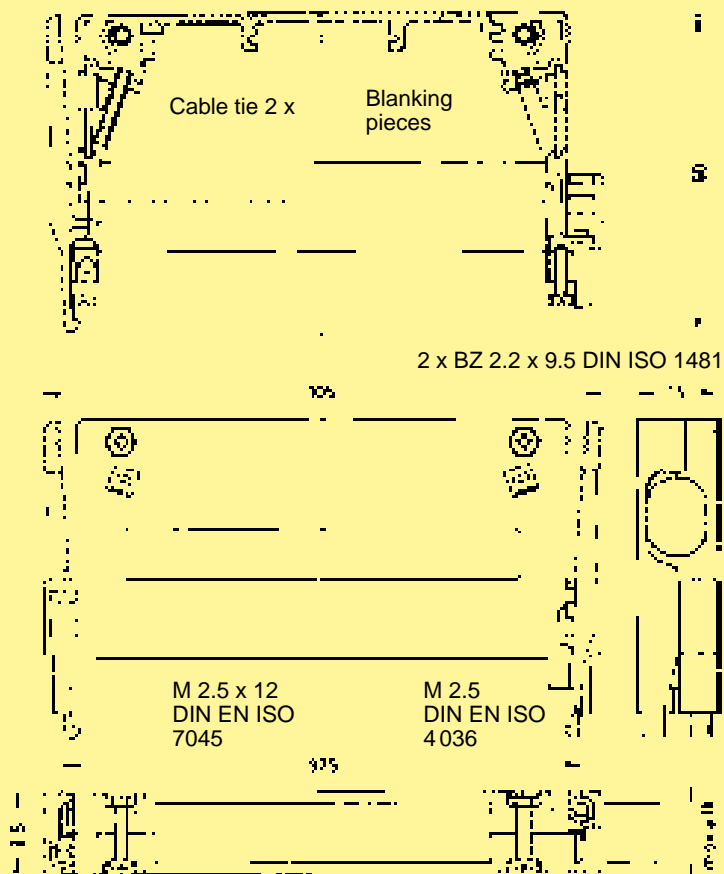

Mechanical guiding and first mating ground connection

II

09 06 000 9961



Locking screws

III

09 06 000 9926¹⁾

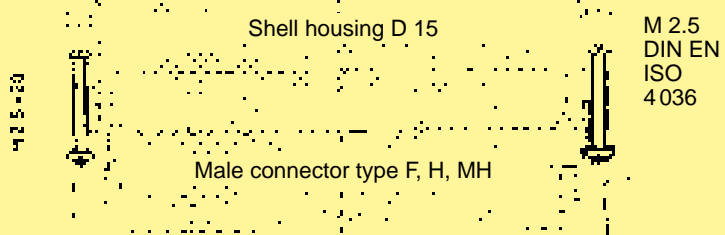

¹⁾ Order 2 pieces for one shell housing

¹⁾ Railway classification NFF 16-101, Smoke index: F1, Flammability class: I2

Shell housings

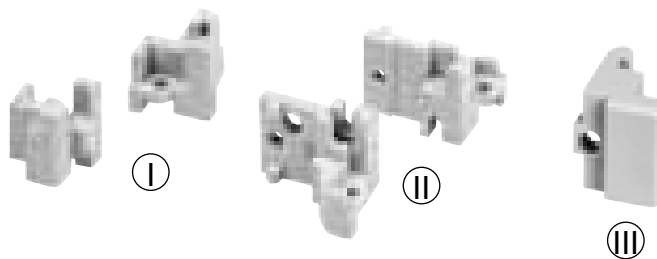

Accessories

Identification Part No. Drawing Dimensions in mm

Fixing brackets B for male connectors
for 19" racks according to DIN EN 60 297, part 3-101

Multiple fixing

without nut



left
09 06 000 9907

right
09 06 000 9908

with nut
M 2.5 DIN 562

left
09 06 000 9966

right
09 06 000 9967

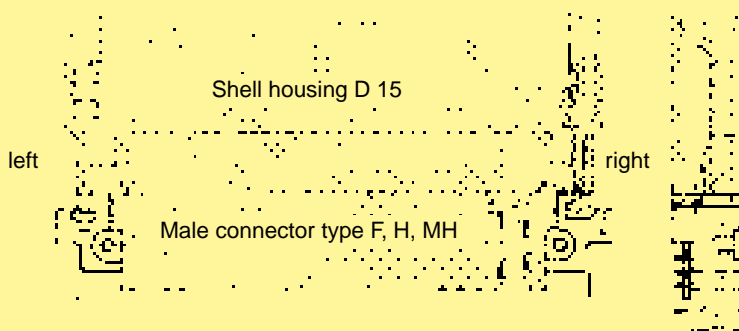

Single fixing

without nut



left
09 06 000 9909

right
09 06 000 9910

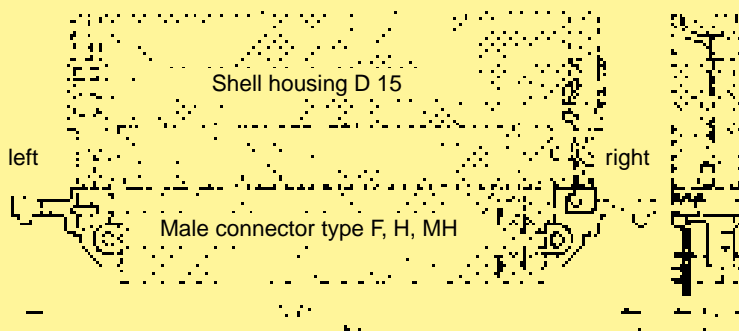

Fixing brackets B for female connectors
for 19" racks according to DIN EN 60 297, part 3-101

Multiple fixing



09 06 000 9933¹⁾

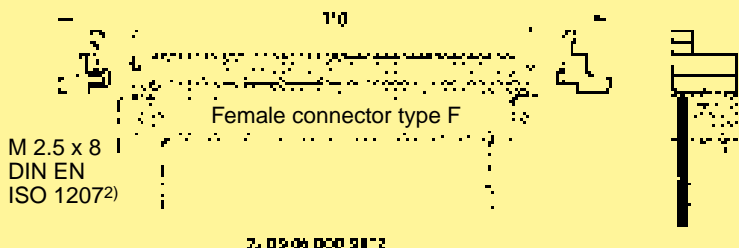

¹⁾ Order 2 pieces for one female connector

²⁾ nut and screw not supplied with fixing brackets

Open hood G, junction element O, locking lever

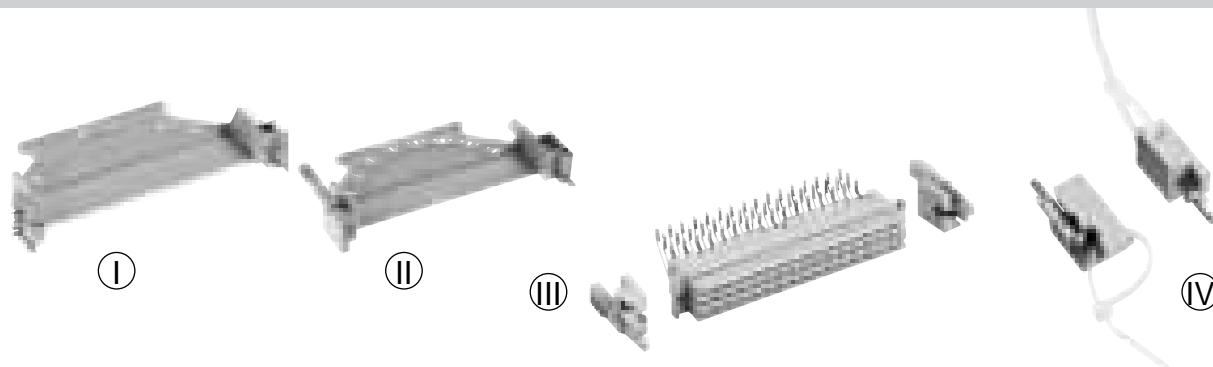

Identification	Part No.	Drawing	Dimensions in mm
<p>Open hood G I</p> <p>for types E, F, H and MH, for applications A B C</p> <p>Supplied with: Open hood 1x Locking screw 2x (09 06 000 9958) Cable tie 1x Screw 2x</p>	09 06 000 9957	<p>2 x ST 2.2 x 9.5 F-Z; E1U; ISO 7049</p> <p>Cable tie 1 x</p>	
<p>Open hood G II</p> <p>for types E, F, H and MH, for application C</p> <p>Supplied with: Open hood 1x Pre-assembled, undetachable locking screw 2x Cable tie 1x Screw 2x</p>	09 06 001 9939		<p>Female connector</p> <p>I element</p> <p>Female connector</p> <p>U element</p> <p>Fixing brackets B</p> <p>Male connector</p>
<p>Junction element O</p> <p>for type F</p> <p>IV</p> <p>Supplied with: Junction element 2x Cable tie 2x Screw 2x Screw M2.5 x 20 2x</p>	09 06 000 9968	<p>2 x ST 2.2 x 9.5 F-Z; E1U; ISO 7049</p> <p>2 x M 2.5 x 20 DIN EN ISO 7045</p>	
<p>Locking lever</p> <p>for type F, H and MH</p> <p>III</p> <p>¹⁾ Order 2 pieces for one female connector</p>	09 06 000 9930 ¹⁾	<p>M 2.5 x 8 DIN EN ISO 1207²⁾</p> <p>Female connector</p> <p>M 2.5 DIN EN ISO 4 032²⁾</p> <p>M 2.5 x 8 DIN EN ISO 1207²⁾</p> <p>Female connector type F</p> <p>M 2.5 DIN EN ISO 4 032²⁾</p>	
	09 06 000 9911 ¹⁾		<p>²⁾ nut and screw not supplied with locking levers</p>

Shell housings

Shell housing D 20/2 for types F, H and MH

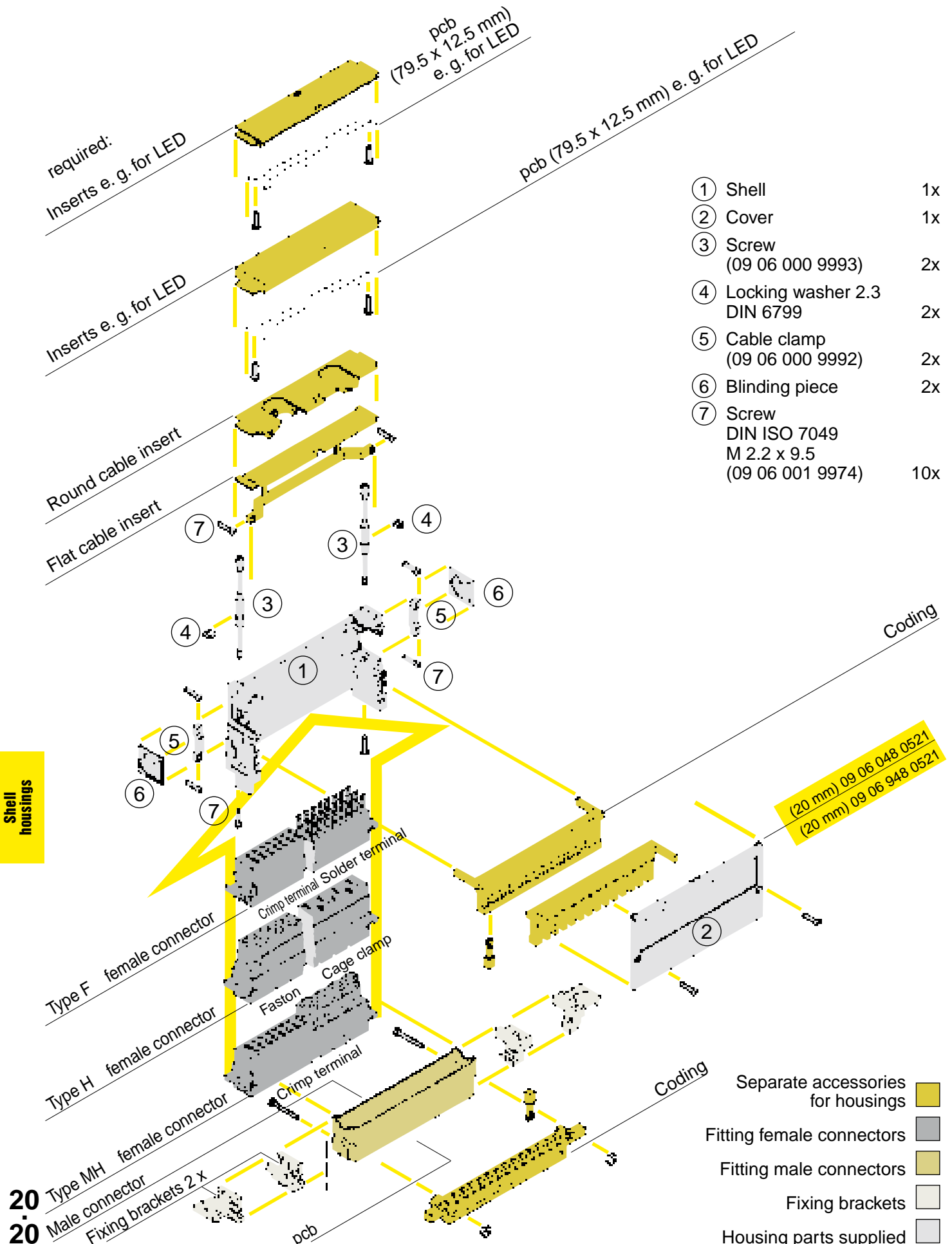

①	Shell	1x
②	Cover	1x
③	Screw (09 06 000 9993)	2x
④	Locking washer 2.3 DIN 6799	2x
⑤	Cable clamp (09 06 000 9992)	2x
⑥	Blinding piece	2x
⑦	Screw DIN ISO 7049 M 2.2 x 9.5 (09 06 001 9974)	10x

Shell housings

20 Type MH female connector

20 Male connector

Fixing brackets 2 x

Separate accessories for housings	
Fitting female connectors	
Fitting male connectors	
Fixing brackets	
Housing parts supplied	

Moulding material: thermoplastic resin, glass-fibre filled, UL 94-V0

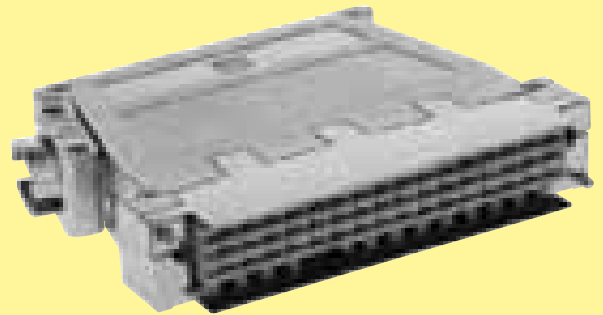
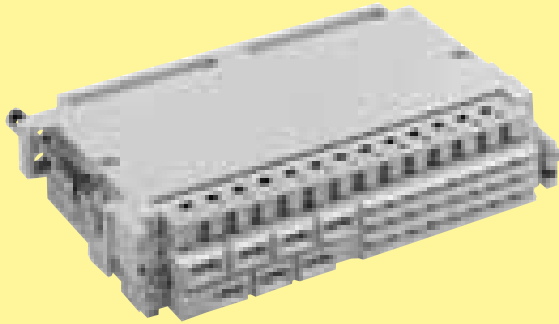

Fitting female connectors

Part-No.	Type	D 20/2	D 20/4	D 20 metal	D 20 metal HF
09 06 2__ 823	F with open solder lugs	X		X	X
09 06 2__ 853	F with closed solder lugs	X		X	X
09 06 248 3201	F moulding for crimp contacts	X	X	X	X
09 06 215 2871	H for faston	X		X	X
09 06 015 2813	H with cage clamps	X		X	X
09 06 231 2881	MH moulding for crimp contacts	X		X	X

Order example:

09 06 2__ 853

32 = 32 contacts
48 = 48 contacts



7 = performance level 3
6 = performance level 2
2 = performance level 1

Technical characteristics

	D 20/2	D 20/2 metallised ¹⁾	D 20/4	D 20/4 metallised ¹⁾	D 20 metal	D 20 metal HF
Part No.	09 06 048 0521	09 06 948 0521	09 06 048 0522	09 06 948 0522	09 06 848 0550	09 06 848 0551
Material	Polycarbonate	Polycarbonate	Polycarbonate	Polycarbonate	Zinc alloy	Zinc alloy
Surface	none	nickel/copper	none	nickel/copper	nickel-plated	nickel-plated
Weight [g]	36	44	43	52	182	188
Cable entries	side (2 x), top (2 x)	side (2 x), top (2 x)	side (4 x)	side (4 x)	side (2 x), top (2 x)	side (2 x) top (2 x)
Protection	IP 20	IP 20	IP 20	IP 20	IP 20	IP 20

¹⁾ upper temperature limit is +105 °C

Shell housing D 20 for types F, H and MH

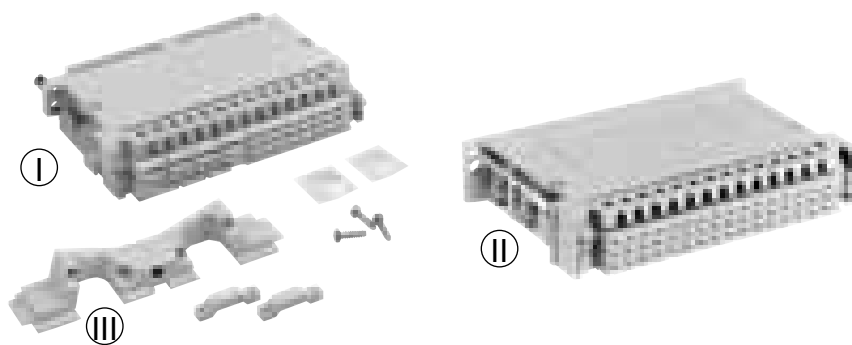

Shell housings

20
-
22

Identification	Part No.	Drawing	Dimensions in mm
Shell housing D 20/2 Two side cable entries I	20 mm 09 06 048 0521		
Shell housing D 20/4 Four side cable entries II Supplied with: Shell 1x Cover 1x Locking screw 2x (09 06 000 9920) Locking washer 2.3 2x Screw BZ 2.2x9.5 12x Blinding piece 3x Cable clamp 2x	20 mm 09 06 048 0522		
Inserts e. g. for LED* for 55 mm height	09 06 000 9986		pcb
for 60 mm height	09 06 000 9987		pcb
Round cable insert* 2 x ø 11 III	09 06 000 9988		
Flat cable insert*	09 06 000 9989		

* Fits D 20/2
 Railway classification NFF 16-101, Smoke index: F1, Flammability class: I2

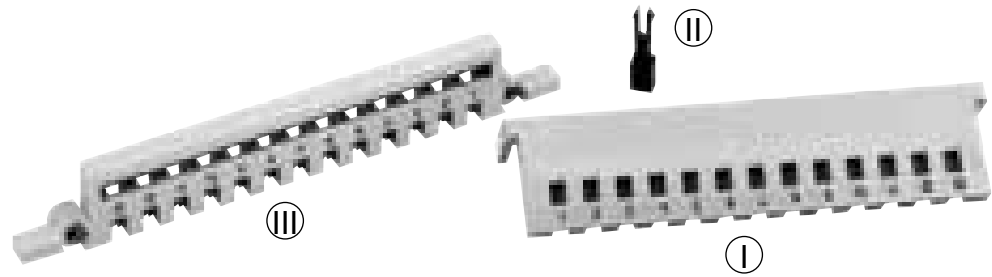

Coding

Identification	Part No.	Drawing	Dimensions in mm
<p>Code comb for shell housing³⁾ (can also be used as a blanking cover)</p> <p>Ⓚ</p>	09 06 000 9984 ^{f)}		
<p>Coding pin³⁾</p> <p>Ⓛ</p> <p>¹⁾ Order 13 pieces per code comb</p>	09 06 001 9905 ¹⁾	<p>Order 13 pieces per code comb</p>	
<p>Code comb for male connectors³⁾</p> <p>Ⓜ</p> <p>short version for a full metal locking lever</p>	<p>09 06 000 9985^{f)}</p> <p>09 06 001 9985^{f)}</p>		
<p>Mounting possibilities for the code comb in the shell housing D 20/2</p>		<p>²⁾ Use the lower slot when coding the male connector with fixing brackets</p> <p>Mounting example A max. cable entry \varnothing 14 mm to the top, see page 20.25</p> <p>Mounting example B max. cable entry \varnothing 14 mm to the bottom, see page 20.25</p>	

³⁾ Fits D 20/2 and D 20/4

^{f)} Railway classification NFF 16-101, Smoke index: F1, Flammability class: I2

Identification	Part No.	Drawing	Dimensions in mm
<p>Mounting possibilities for code comb at the male connector with fixing brackets</p>		<p>M 2.5 x 18 DIN EN ISO 1207</p> <p>pcb</p> <p>M 2.5</p> <p>M 2.5 DIN EN ISO 4036</p>	
<p>Fixing brackets B for male connectors* for 19" racks according to DIN EN 60297, part 3-101</p> <p>Single fixing* without nut</p> <p>with nut M 2.5 DIN 562</p>	<p>left 09 06 000 9909</p> <p>right 09 06 000 9910</p> <p>left 09 06 001 9934</p> <p>right 09 06 001 9935</p>	<p>Shell housing D 20</p> <p>left right</p> <p>M 2.5 DIN 562</p>	
<p>Multiple fixing* without coding at the fixing bracket without nut</p> <p>without coding at the fixing bracket with nut M 2.5 DIN 562</p> <p>with coding at fixing bracket¹⁾ with nut M 2.5 DIN 562</p> <p>15 mm 20 mm</p> <p>15 mm 20 mm</p>	<p>left 09 06 000 9907</p> <p>right 09 06 000 9908</p> <p>left 09 06 000 9966</p> <p>right 09 06 000 9967</p> <p>left 09 06 000 9995 09 06 000 9997</p> <p>right 09 06 000 9996 09 06 000 9998</p>	<p>Shell housing D 20</p> <p>left right</p> <p>M 2.5 DIN 562</p> <p>Shell housing D 20</p> <p>left right</p> <p>09 06 000 9995 09 06 000 9997</p>	<p>mounting examples</p>
<p>Protection and fixing strip* for 20 mm shell housing</p> <p>Single fixing fits female connectors and I element crimp</p>	<p>09 06 001 9909</p>		

Shell housings

20
-
24

* Fits D 20/2 and D 20/4
¹⁾ Specific coding between the fixing bracket and the pcb guiding rail.
 The guiding rail and corresponding coding pins are not scope of delivery

Mounting examples

Dimensions in mm

Single fixing

Multiple fixing

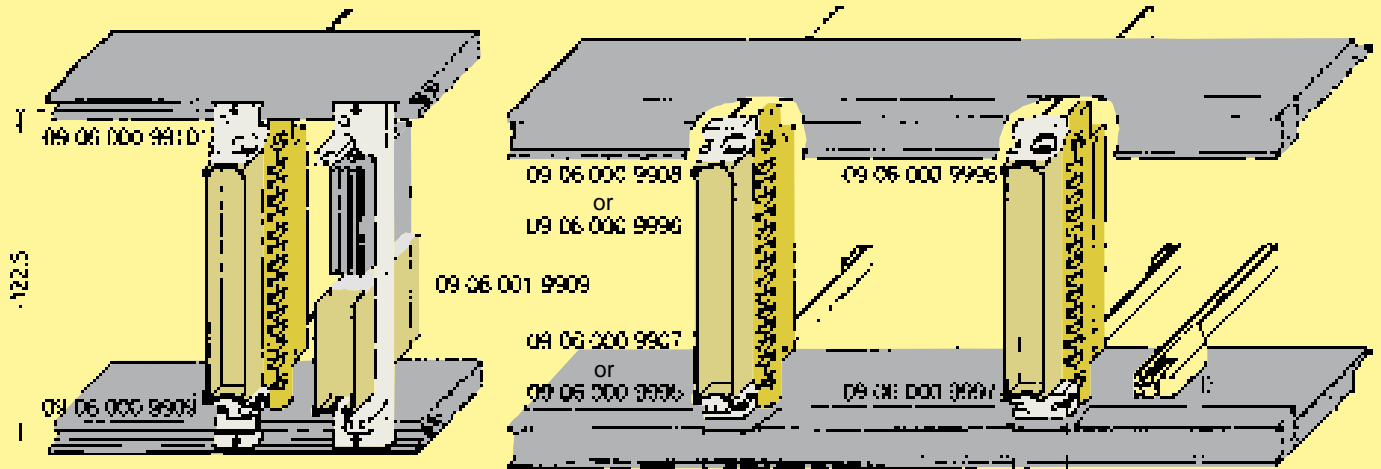

15

26

15

26

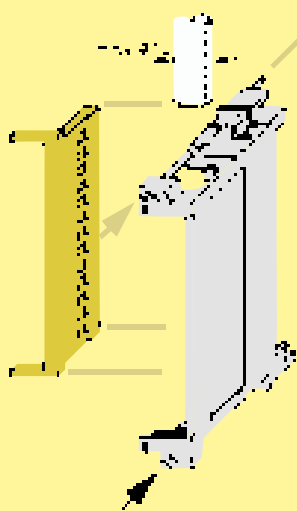

Mounting example A²⁾
max. cable entry to the top

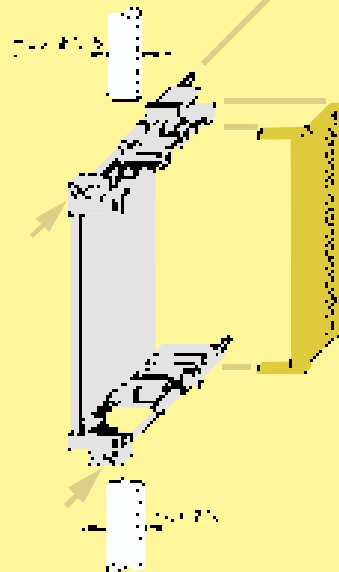

Mounting example B
max. cable entry to the bottom

Separate accessories for housings

Fitting female connectors

Fitting male connectors

Fixing brackets

Housing parts supplied

¹⁾ Specific coding between the fixing bracket and the pcb guiding rail

²⁾ Max. cable entry (\varnothing 14 mm) from the bottom with fixing brackets 09 06 901 9924/...9925 possible. See page 20.31.

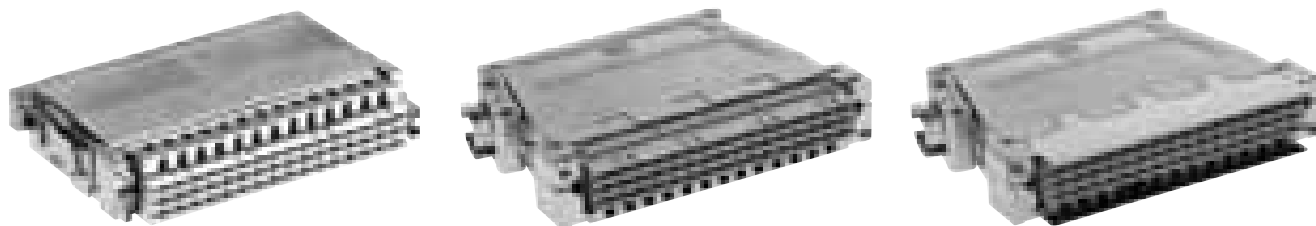

EMC with HARTING connectors

HARTING offers metallised D 20 housings and full metal housings for EMC connectors according to IEC 60603-2. Its strong EMI characteristics and metallised fixing elements offers optimal shielding and grounding.

The connection of the cable braid to different types of connector housings, as well as the influence of the connector itself on EMC characteristics of an instrument application, were analysed in regard to **the shielding effectiveness against electromagnetic radiation**. The shielded signal data lines of a railway application were carried via two eurocard pcb's installed into a 19"-rack. The fixing of the cable braid was realised with different HARTING D 20 housings.

The application including the connectors was then exposed to RF signals, transient bursts and electrostatic discharges.

The standard plastic housings showed minimal EMC performance. The EMC performance of metallised and full metal housings showed significant improvements.

One advantage of metallised housings is their reduced weight (40 grams compared to 180 grams of a full metal housing). Therefore, minimal interference is applied to the pcb in applications where strong vibration is occurring. The HARTING housings are comparatively light through the use of metallised plastic.

The main advantages of a full metal housing are improved cable braid fixing, easy mounting and robustness.

In general, one should keep in mind that an unshielded cable entry leads to loss of the shielding against electromagnetic interference.

“A high-resistance interruption of the cable shield (e.g. by using “pigtailed” via twisted stranded wires of the cable shield) may affect the EMC performance and therefore cause unacceptable effects to the electromagnetic environment.”

These housings are applied in electronic installations of the railway vehicles of the GERMAN RAILWAY. They are also recommended for stationary installations of the GERMAN RAILWAY (see norm BN 74016, part 1 of December 1989).

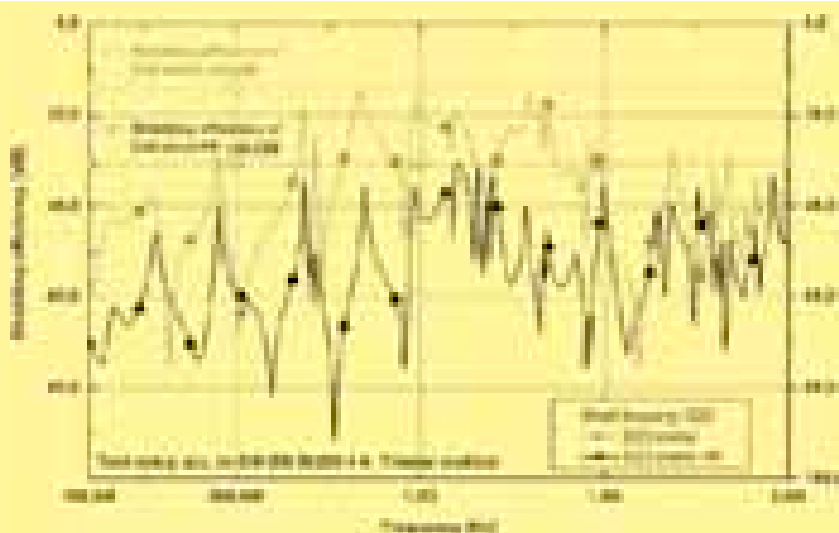

Shell housing D 20 metallised for types F, H and MH

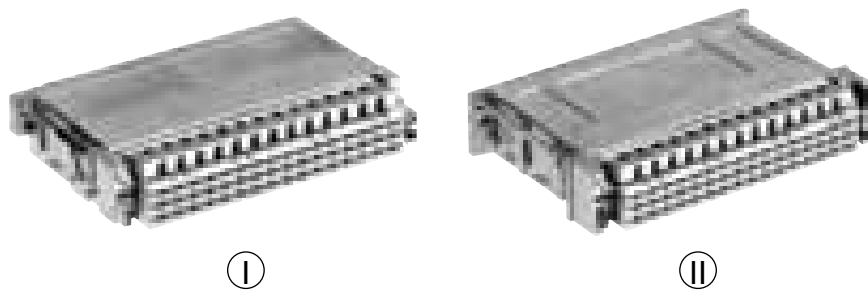

I

II

Identification	Part No.	Drawing	Dimensions in mm
<p>Shell housing D 20/2 metallised with two side cable entries</p> <p>I</p> <p>Supplied with: see page 20.20</p>	<p>20 mm 09 06 948 0521</p>	<p>Order inserts separately</p> <p>Blanking piece 2 x</p>	
<p>Shell housing D 20/4 metallised with four side cable entries</p> <p>II</p> <p>Supplied with: Shell 1x Cover 1x Locking screw 2x (09 06 000 9920) Locking washer 2.3 2x Screw BZ 2.2x9.5 12x (09 06 001 9974) Blinding piece 3x Cable clamp 2x</p>	<p>20 mm 09 06 948 0522</p>		
<p>Metallised insert e. g. for LED*</p> <p>for 55 mm height</p>	<p>09 06 900 9986</p>	<p>pcb</p>	
<p>for 60 mm height</p>	<p>09 06 900 9987</p>	<p>pcb</p>	
<p>Metallised round cable insert* 2 x \varnothing 11</p>	<p>09 06 900 9988</p>		

Shell
 housings

20
27

* Fits D 20/2 metallised
Railway classification NFF 16-101, Smoke index: F1, Flammability class: I2

Shell housing D 20 metallised

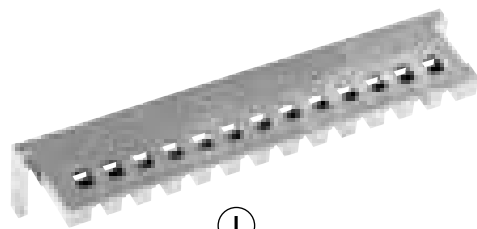

ⓘ

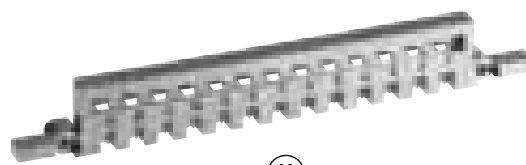

Ⓜ

Coding

Identification Part No. Drawing Dimensions in mm

Metallised code comb for shell housing³⁾
(can also be used as blanking cover)

ⓘ

09 06 900 9984^{f)}

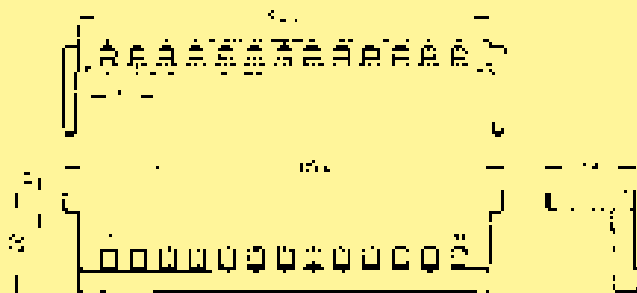

Code pin³⁾

09 06 001 9905¹⁾

Order 13 pieces per code comb

¹⁾ Order 13 pieces per code comb

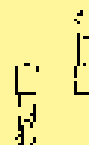

Metallised code comb for male connector³⁾

Ⓜ

09 06 900 9985^{f)}

09 06 901 9985^{f)}

short version for a full metal locking lever



Mounting possibilities for the code comb in shell housing D 20/2 metallised

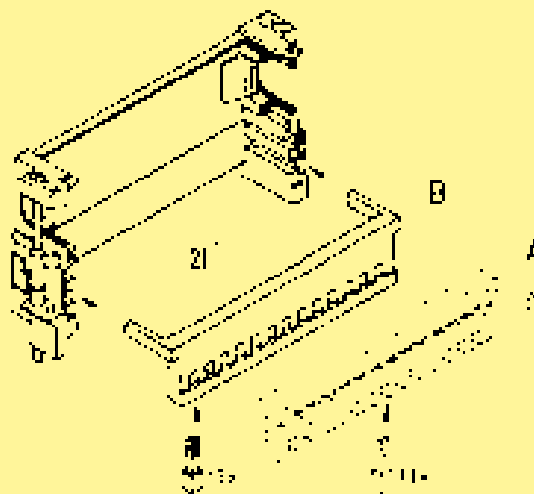

²⁾ Use the lower slot when coding the male connector with fixing brackets

Mounting example **A** max. cable entry \varnothing 14 mm to the top, see page 20.25

Mounting example **B** max. cable entry \varnothing 14 mm to the bottom, see page 20.25

Shell housings

³⁾ Fits D 20/2 and D 20/4 metallised

^{f)} Railway classification NFF 16-101, Smoke index: F1, Flammability class: I2

Identification	Part No.	Drawing	Dimensions in mm
<p>Mounting possibilities for coding at the male connector with fixing brackets</p>			
<p>Fixing brackets B metallised for male connectors* for 19" racks according to DIN EN 60297, part 3-101</p> <p>Single fixing* without nut</p> <p>with nut M 2.5 DIN EN ISO 4036</p>	<p>left 09 06 900 9909 right 09 06 900 9910</p> <p>left 09 06 901 9934 right 09 06 901 9935</p>		
<p>Multiple fixing* without coding at fixing bracket without nut</p> <p>without coding at fixing bracket with nut M 2.5 DIN 562</p> <p>with coding at fixing bracket¹⁾ with nut M 2.5 DIN 562</p>	<p>left 09 06 900 9907 right 09 06 900 9908</p> <p>left 09 06 900 9966 right 09 06 900 9967</p> <p>left 15 mm 09 06 900 9995 20 mm 09 06 900 9997</p> <p>right 15 mm 09 06 900 9996</p>		
<p>Protection and fixing* strip for 20 mm shell housing Single fixing fits female connectors and I element crimp</p>	<p>09 06 901 9909</p>		

* Fits D 20/2 and D 20/4 metallised

¹⁾ Specific coding between the fixing bracket and pcb guiding rail

Shell housing D 20 metal for types F, H and MH

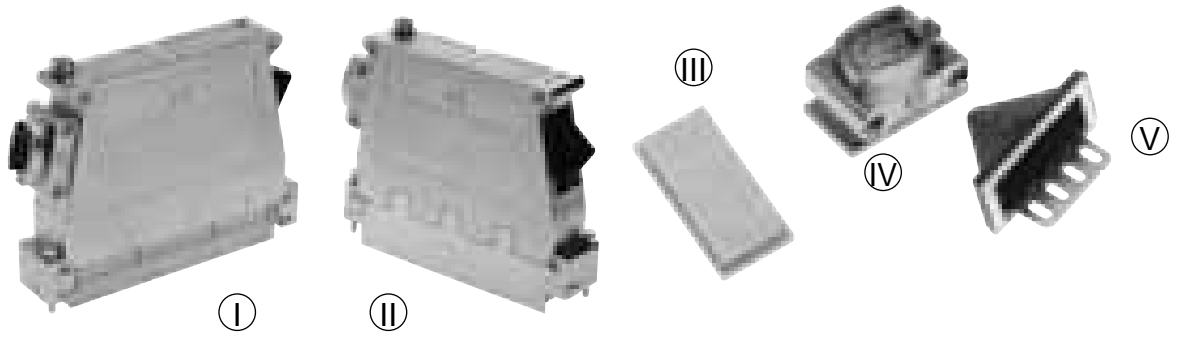

Shell housings

20
-
30

Identification	Part No.	Drawing	Dimensions in mm
Shell housing D 20 metal ① Supplied with: Shell with coding 1x Cover 1x Locking screw (hexagonal) M2.5 x 22 (09 06 800 9953) 2x Screw (torx) M2.5 x 10 (09 06 800 9960) 4x Earth screw M4 x 8 (09 06 800 9958) 2x	09 06 848 0550		
Shell housing D 20 metal HF with nickel-plated surface ② Supplied with: Shell with coding and HF-sealing spring 1x Cover with shielding plate 1x Locking screw (hexagonal) M2.5 x 22 (09 06 800 9953) 2x Screw (torx) M2.5 x 10 (09 06 800 9960) 4x Earth screw M4 x 8 (09 06 800 9958) 2x	09 06 848 0551		
Blinding piece ③	09 06 800 9951		
Cable clamp ④	09 06 800 9955		
Cable grommet with strain relief ⑤	09 06 800 9950		

Shell housing D 20 metal HF for types F, H and MH

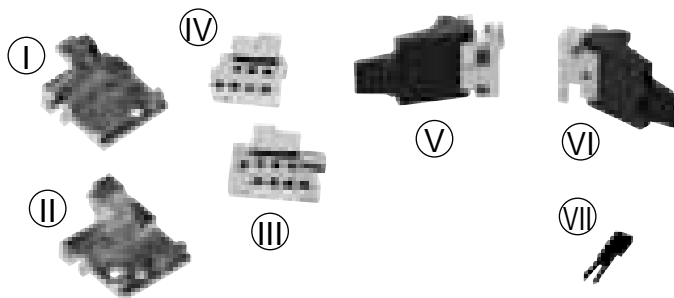

Identification	Part No.	Drawing	Dimensions in mm
<p>Fixing brackets B metallised for male connectors for 19" racks according to DIN EN 60297, part 3-101</p> <p>Single fixing (I) with nut M 2.5 DIN EN ISO 4036 (II)</p>	<p>left 20 mm 09 06 901 9924^{f)}</p> <p>right 20 mm 09 06 901 9925^{f)}</p>	<p>Shell housing D 20</p> <p>left right</p> <p>M 2.5 DIN EN ISO 4036</p>	
<p>Multiple fixing with coding at fixing bracket with nut M 2.5 DIN 562 (III)</p>	<p>left 20 mm 09 06 900 9997^{f)}</p>	<p>Shell housing D 20</p> <p>left right</p>	
<p>Fixing brackets B metal for male connectors for 19" racks according to DIN EN 60297, part 3-101</p> <p>Single fixing (V) with ejector handle (VI)</p>	<p>left 09 06 800 9946</p> <p>right 09 06 800 9948</p>	<p>Shell housing D 20</p> <p>left right</p>	
<p>Crimp flange insert 09 06 800 9952</p>	09 06 800 9952		
<p>Cable clamp cable-Ø appr. 5- 7 mm cable-Ø appr. 7-10 mm cable-Ø appr. 10-12 mm</p>	<p>61 03 000 0141</p> <p>61 03 000 0044</p> <p>61 03 000 0143</p>		
<p>Blanking piece for hoods 61 03 000 0042</p>	61 03 000 0042		
<p>Code pin (VII) 09 06 001 9905</p>	09 06 001 9905		
<p>Earth screw M4 x 8 09 06 800 9958</p>	09 06 800 9958		

^{f)} Railway classification NFF 16-101, Smoke index: F1, Flammability class: I2

For applications where robust, high density, splash-proof connectors are required, e.g. in the automated control and industrial processing systems, HARTING have combined the proven reliability of DIN 41 612 connectors with standard Han® 24 B heavy duty hoods and housings, to bring forward a connector system with up to 96 ways and various contact plating thicknesses to suit the individual requirements.

Advantages

- The combination enhances design flexibility, as it permits an identical wiring interface between the standard 19" racking systems and the peripheral equipment.
- Simplified stock-holding, identical operating tools.

Inserts

Female	2 x 48 way type F female connectors with crimp contact elements see chapter 03
Male	2 x 48 way type F interface connectors I with crimp contact elements see chapter 03

Hoods and housings

see catalogue "Heavy Duty Han® Connectors"

chapter 30
size 24 B

Degree of protection for hoods and housings: IP 65

Retaining frames

For fixing the inserts into the housing.

Alternative versions with pre-mating contacts and ground termination.

If the working voltages are in excess of 42 V (50 V) it is essential to use retaining frames which have pre-mating ground contacts.

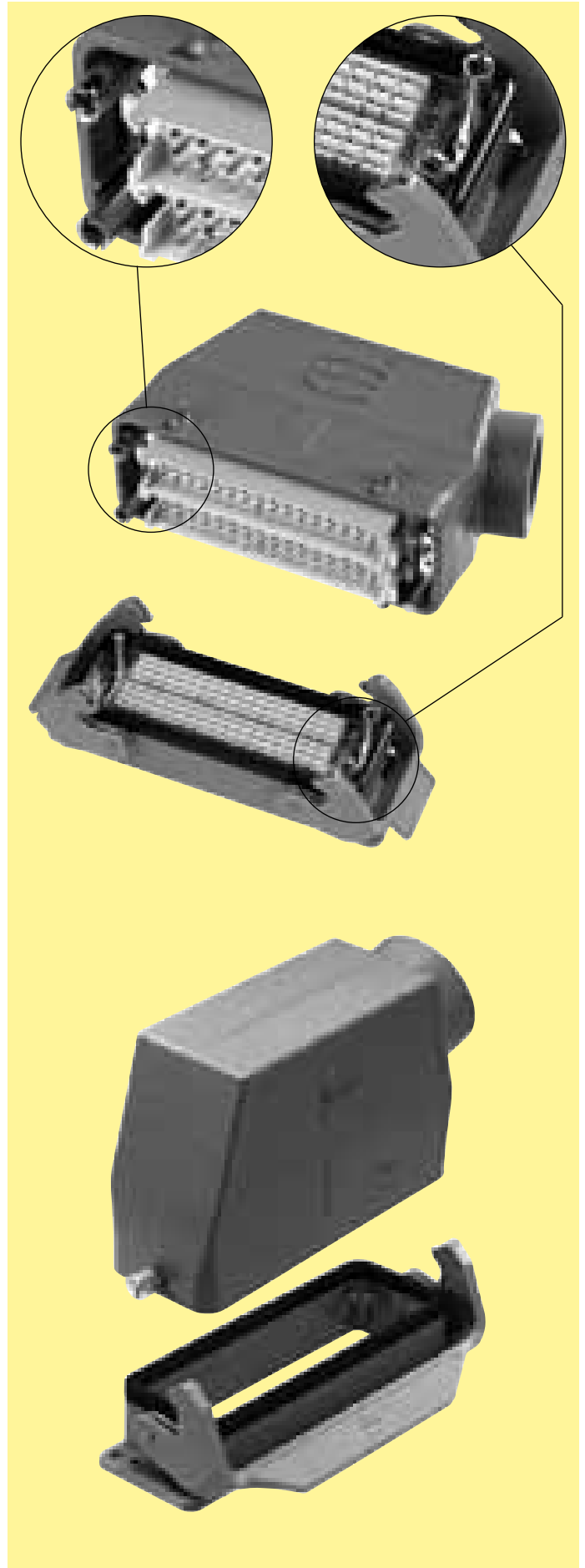

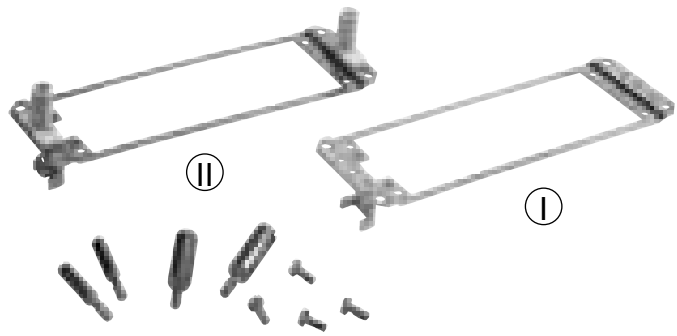

Identification	Part No.	Drawing	Dimensions in mm
----------------	----------	---------	------------------

Retaining frame without contact elements

Ⓘ

09 06 001 9904

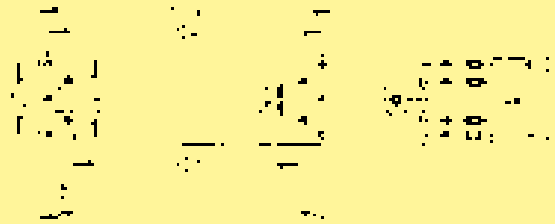

Retaining frame with 2 contact pins and ground termination

09 06 001 9902

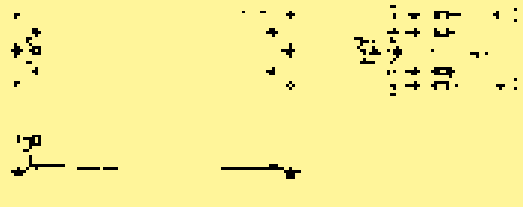

Retaining frame with 2 contact sockets and ground termination

09 06 001 9903

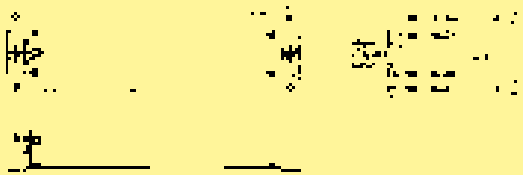

Ⓜ

Each retaining frame is supplied with 4 fixing screws for mounting the inserts and with 2 guide pins and sockets that provide mechanical protection for the contacts during mating and disconnection. These can also be used as a coding system to prevent cross plugging of adjacent connectors.

Mounting example

Connectors in the retaining frame with contact sockets

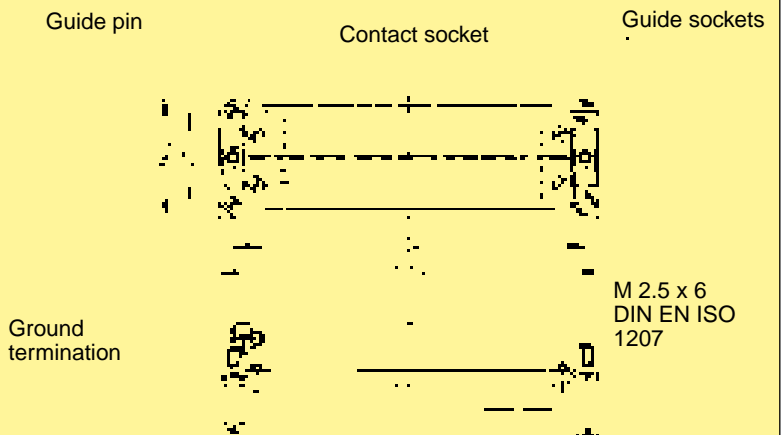

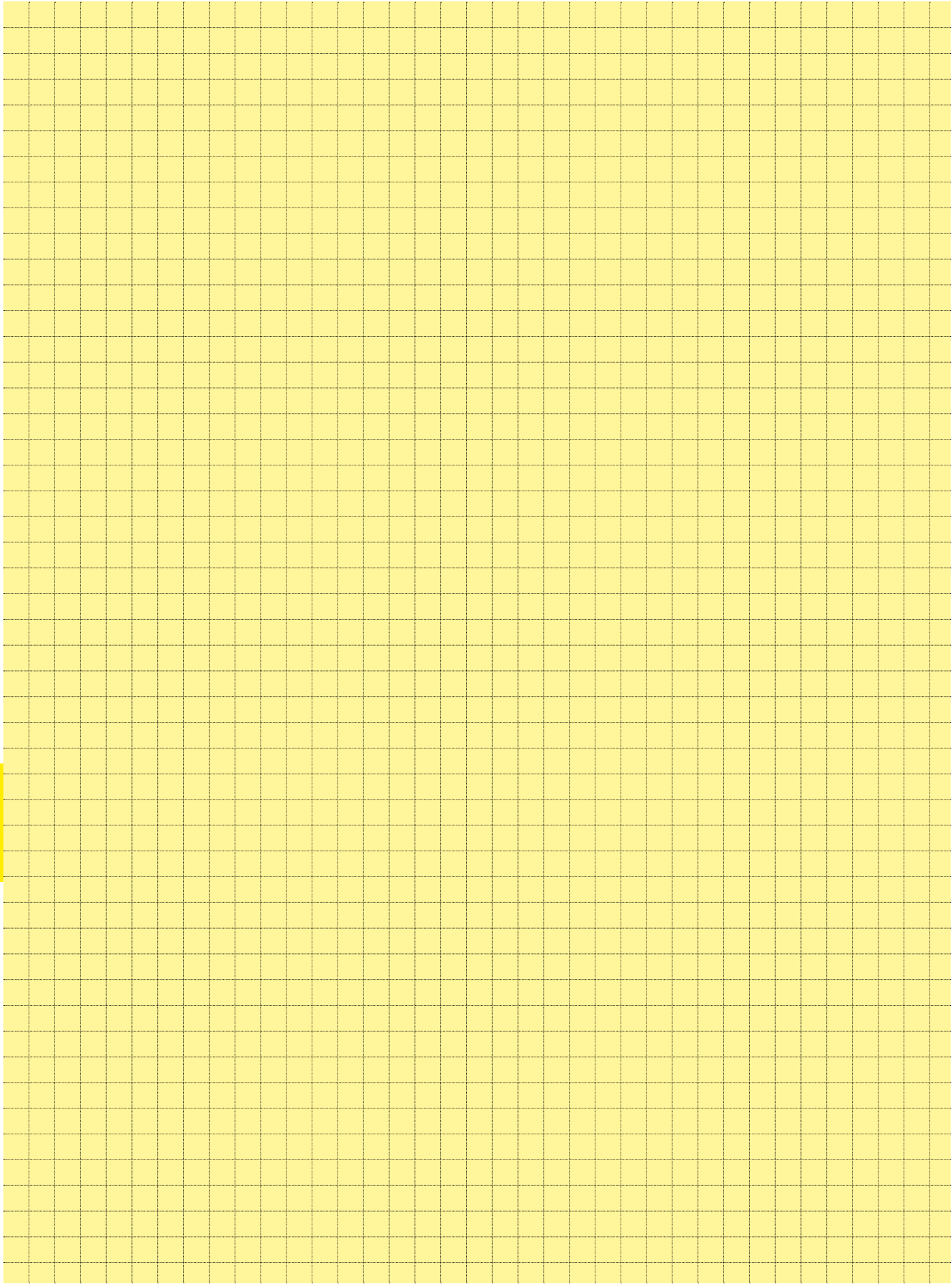



Tooling

Page

Press-in technology

Modular tooling system for starting connector press-in **30.02**

Handling indications **30.03**

Press-in tooling **30.05**

Repair tooling **30.07**

Hand bench presses / pneumatic presses **30.11**

CPM press-in machines **30.12**

Crimp technology

Manual crimping tools. **30.16**

Insertion and removal tools **30.16**

Semiautomatic crimping tools **30.17**

Automatic crimping tools **30.18**

Tooling

The diversity of connector types with press-in terminations and varying termination styles make it necessary to have a simple, flexible tooling system that can be continuously updated.

The HARTING modular tooling system has significant advantages in terms of economic assembly of the many connector types with press-in terminations. The basic modules of the tooling system which will always be required are:

- Press
- Top tool
- Bottom tool
- Base plate

To increase automation and productivity the following modules may be added to the basic assembly:

- Guide frame with base plate for accurate positioning of the pcb up to a length of 600 mm
- Guide frame "Standard" for hand bench press and pneumatic press and pcb height of 123.5 up to 309.5 mm
- Guide frame "Long" for pneumatic press and pcb height of 123.5 up to 668.5 mm

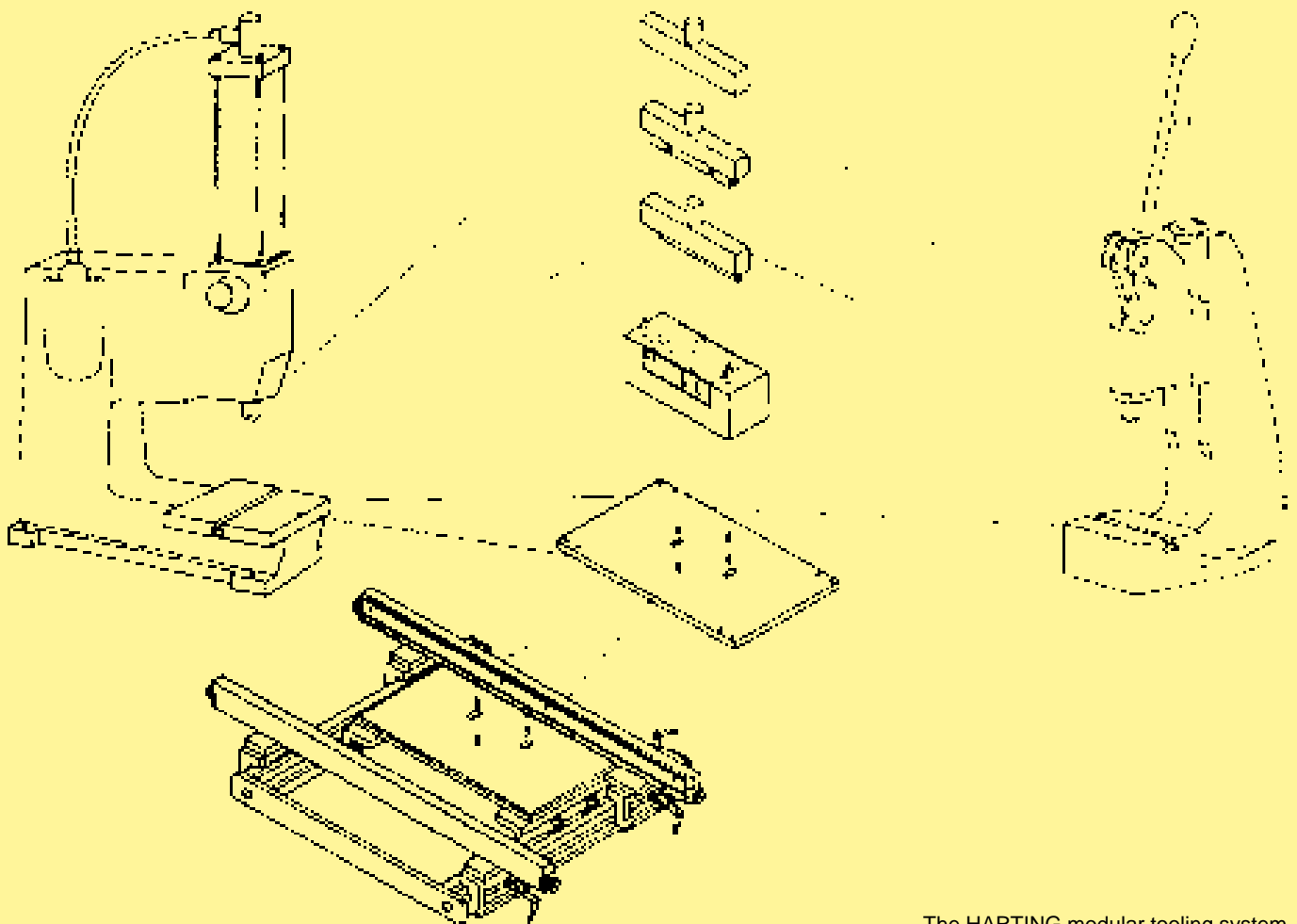

When setting up an assembly machine it is not necessary to set the working height of the press and adjust the base plate more than once. There is no need for further adjustments. All the other adaptations for various applications are performed efficiently and are reliant by various combinations of individual modules.

Positioning the bottom tool in relation to the top tool

The ram of the HARTING press is generally provided with a cross-shaped groove which accurately positions the top tool in steps of 90°.

Two guide pins position the bottom tool in relation to the top tool simply and accurately.

These guide pins cannot be used for positioning the pcb or the connector!

Two pairs of pins on the base plate locate the bottom tool in relation to the top tool in steps of 90°.

Height compensation

- Various overall heights of connectors are accommodated by type-specific top tools.
- Various pcb thicknesses are accommodated by the use of spacers between the bottom tool and base plate.

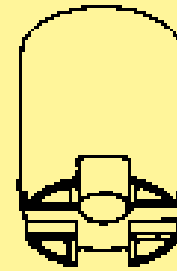

Ram with cross-shaped groove

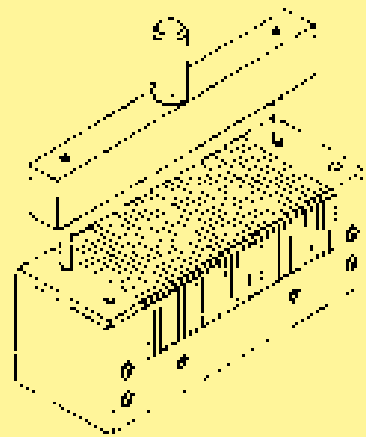

Positioning the bottom tool in relation to top tool

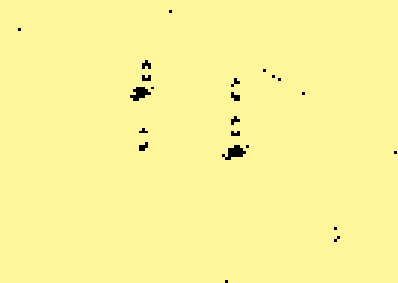

Base plate with pairs of location pins at 90°

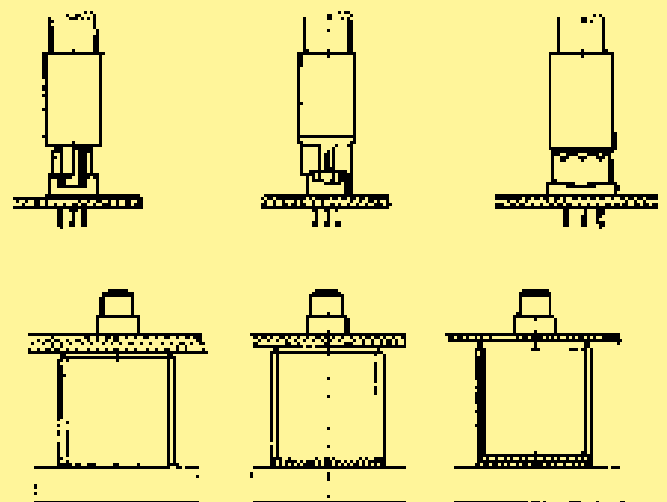

Range of applications for the bottom tool

One bottom tool can be used to assemble connectors with straight or angled press-in terminations.

When pressing in the connectors with angled press-in terminations the positioning pins remain in the bottom tool and serve as guide pins for the connector.

By rotating the bottom tool in steps of 90° and relocating the positioning pins it is possible to assemble half-length connectors with angled press-in terminations.

Bottom tool (narrow version)

In addition to the square bottom tool with multi-functional properties, HARTING offers the alternative of a narrow bottom tool for assembling connectors with straight press-in terminations. This tool supports the pcb within the press-in connector zone and therefore makes it possible to assemble connectors where electronic components are to be placed in close proximity.

Guide frame

The guide frame screwed to the base plate ensures the correct positioning of the pcb in relation to the top and bottom tools and permits a much higher rate of assembly.

Both guide rails are adjustable to accommodate various pcb sizes.

A spring-loaded supporting rail lifts the pcb away from the bottom tool after the press-in operation ensuring that no damage occurs to the conductors as it passes through the machine.

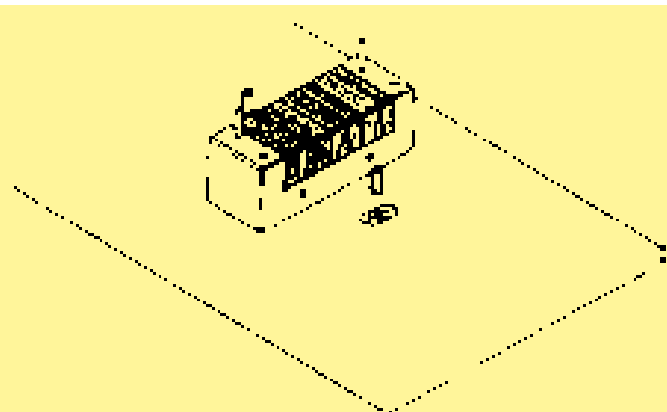

Bottom tool set for assembling connectors with angled pins

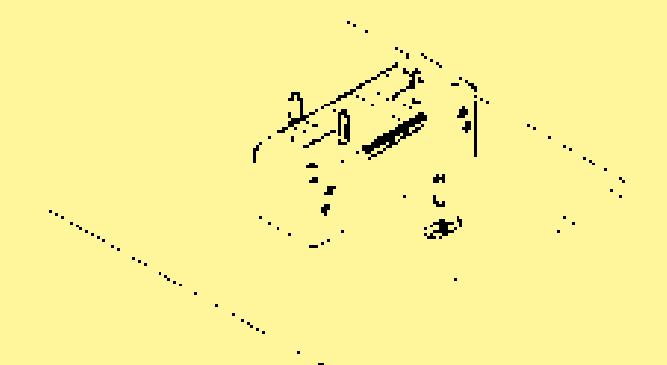

Bottom tool set for assembling half-length connectors with angled pins

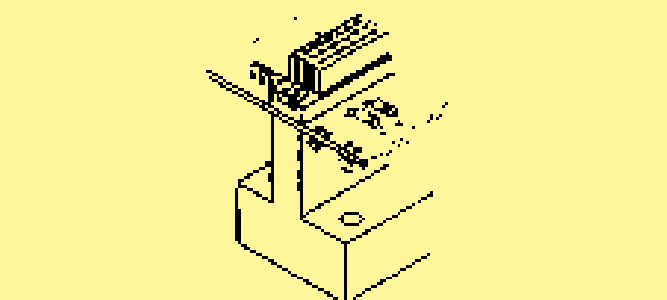

Narrow version of the bottom tool for special applications

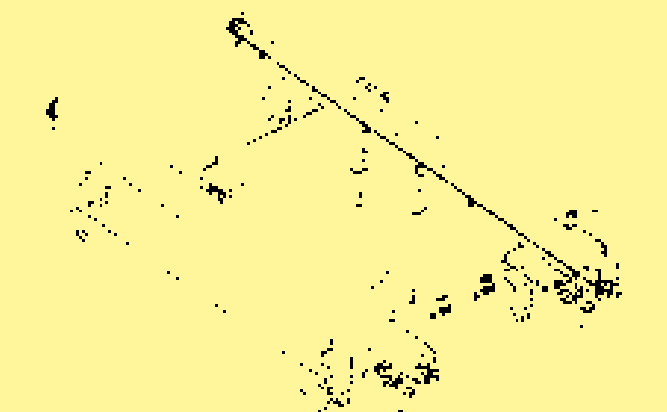

Guide frame for positioning the pcb in relation to the top and bottom tools

Identification	Part No.	Drawing	Dimensions in mm
<p>Bottom tool Universal</p> <p>for use with male and female connectors</p>	<p>Type B, 2B, 3B C, 2C, 3C M Q, 2Q R, 2R E F H har-bus® 64 SEK 18*</p>	<p>09 99 000 0185</p>	
<p>Bottom tool Narrow</p> <p>for use with male connectors</p> <p>for use with female connectors</p>	<p>Type Q, 2Q R, 2R SEK 18*</p> <p>Type B, 2B, 3B C, 2C, 3C M F H</p>	<p>09 99 000 0256</p> <p>09 99 000 0256</p>	
<p>Bottom tool Narrow har-bus® 64</p> <p>for use with female connectors</p>	<p>har-bus® 64</p>	<p>02 99 000 0001</p>	

* Connectors see separate catalogue



Identification	Part No.	Drawing	Dimensions in mm
<p>Top tool without insert block for use with male connectors</p>	<p>Type Q, 2Q R, 2R</p> <p>09 99 000 0181 09 99 000 0183</p>		<p>Type Q, 2Q Type R, 2R</p>
<p>with insert block for use with male connectors</p>	<p>Type Q, 2Q R, 2R</p> <p>09 99 000 0197</p>		<p>Type Q, 2Q, R, 2R</p>
<p>Insert blocks for use with male connectors</p>	<p>Type Q 2Q R 2R</p> <p>09 99 000 0275 09 99 000 0274 09 99 000 0277 09 99 000 0276</p>		
<p>for use with shrouds</p>	<p>har-bus® 64 Type E Type R Type 2R</p> <p>02 09 000 0012 09 99 000 0277 09 99 000 0276</p>		
<p>Top tool for use with female connectors</p>	<p>Type B, 2B, 3B C, 2C, 3C D-Sub* SEK 18* har-mik*</p> <p>Type E F H</p> <p>har-bus® 64</p> <p>Type M (24+8) M (42+6) M (60+4) M (78+2)</p> <p>09 99 000 0197 09 99 000 0221 02 99 000 0002 09 99 000 0269 09 99 000 0270 09 99 000 0271 09 99 000 0272</p>		<p>Type B, 2B, 3B, C, 2C, 3C Type E, F, H har-bus® 64</p>
<p>Top tool only for short posts and pcb thickness > 1.6 mm and without guide frame</p> <p>for use with female connectors</p>	<p>Type C</p> <p>Type F H</p> <p>har-bus® 64</p> <p>09 99 000 0228 09 99 000 0229 02 99 000 0016</p>		<p>Type C Type F, H har-bus® 64</p>

Tooling

* Connectors see separate catalogues

Identification	for use with	Part No.	Drawing	Dimensions in mm															
Removal tool for moulding	Male connectors Type Q 2Q R 2R	09 99 000 0198																	
Removal tool for single male contacts		09 99 000 0239																	
Insertion tool for single male press-in contacts		09 99 000 0200																	
Press-out tool	Termination length 17 mm 13 - 13.2 mm 11.5 mm 4.5 - 5.3 mm	09 99 000 0197 09 99 000 0219 09 99 000 0221 09 99 000 0220		<table border="1"> <thead> <tr> <th>Termination length [mm]</th> <th>x [mm]</th> <th>y [mm]</th> </tr> </thead> <tbody> <tr> <td>17</td> <td>12</td> <td>18.7</td> </tr> <tr> <td>13 - 13.2</td> <td>12</td> <td>22.7</td> </tr> <tr> <td>11.5</td> <td>14</td> <td>20.1</td> </tr> <tr> <td>4.5 - 5.3</td> <td>12</td> <td>30.2</td> </tr> </tbody> </table> <p>With the different dimension y no adjustment of hand bench press necessary.</p>	Termination length [mm]	x [mm]	y [mm]	17	12	18.7	13 - 13.2	12	22.7	11.5	14	20.1	4.5 - 5.3	12	30.2
Termination length [mm]	x [mm]	y [mm]																	
17	12	18.7																	
13 - 13.2	12	22.7																	
11.5	14	20.1																	
4.5 - 5.3	12	30.2																	
Termination support for protection against bending of 13 mm - 17 mm terminations	Male connectors Type Q, 2Q R, 2R Female connectors Type B, 2B, 3B C, 2C, 3C	09 99 000 0240																	
	Female connectors Type F	09 99 000 0241																	
Support block for repair and removal	Male connectors Type Q, 2Q R, 2R SEK 18* Female connectors Type B, 2B, 3B C, 2C, 3C F	09 99 000 0218																	

* Connectors see separate catalogue

Replacement of single male press-in contacts

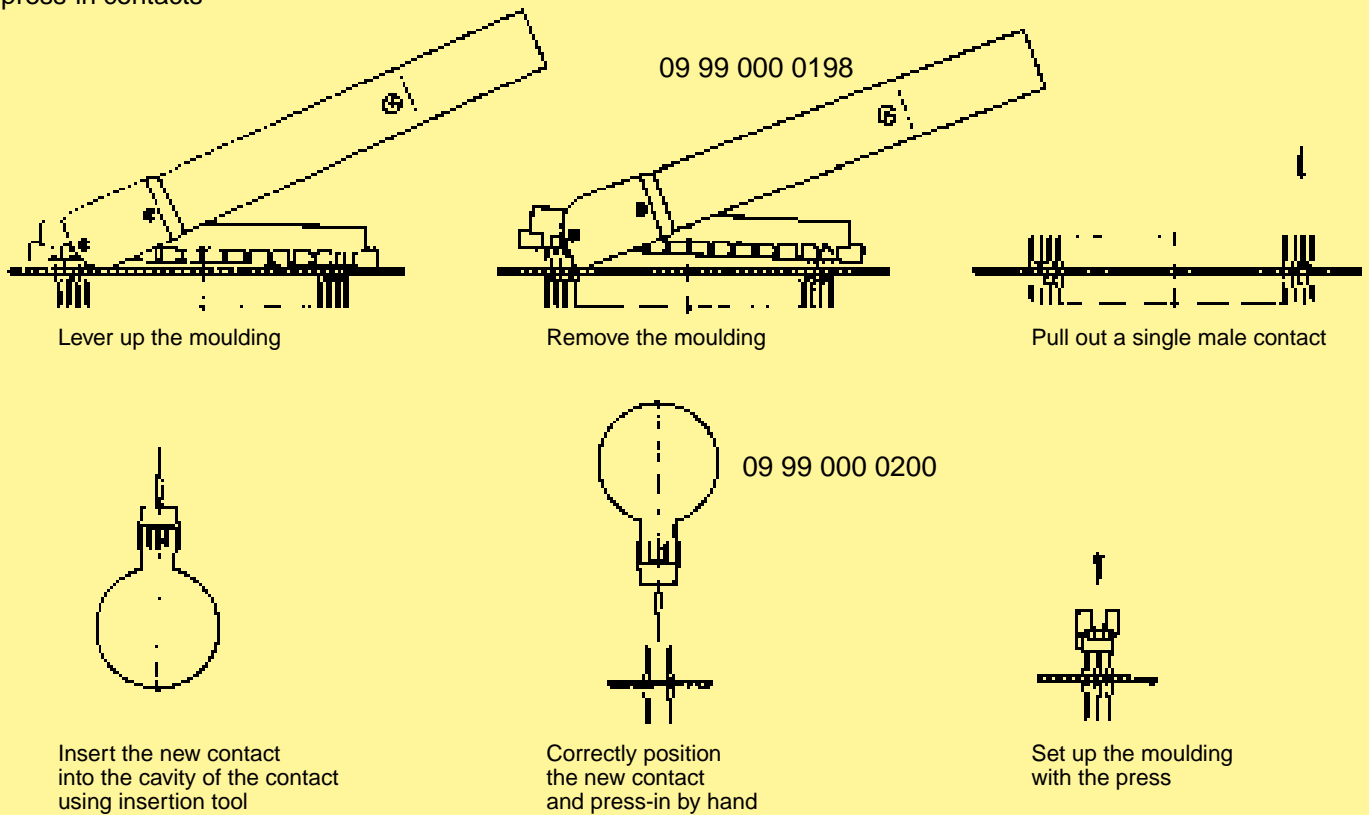

Replacement of complete press-in connectors

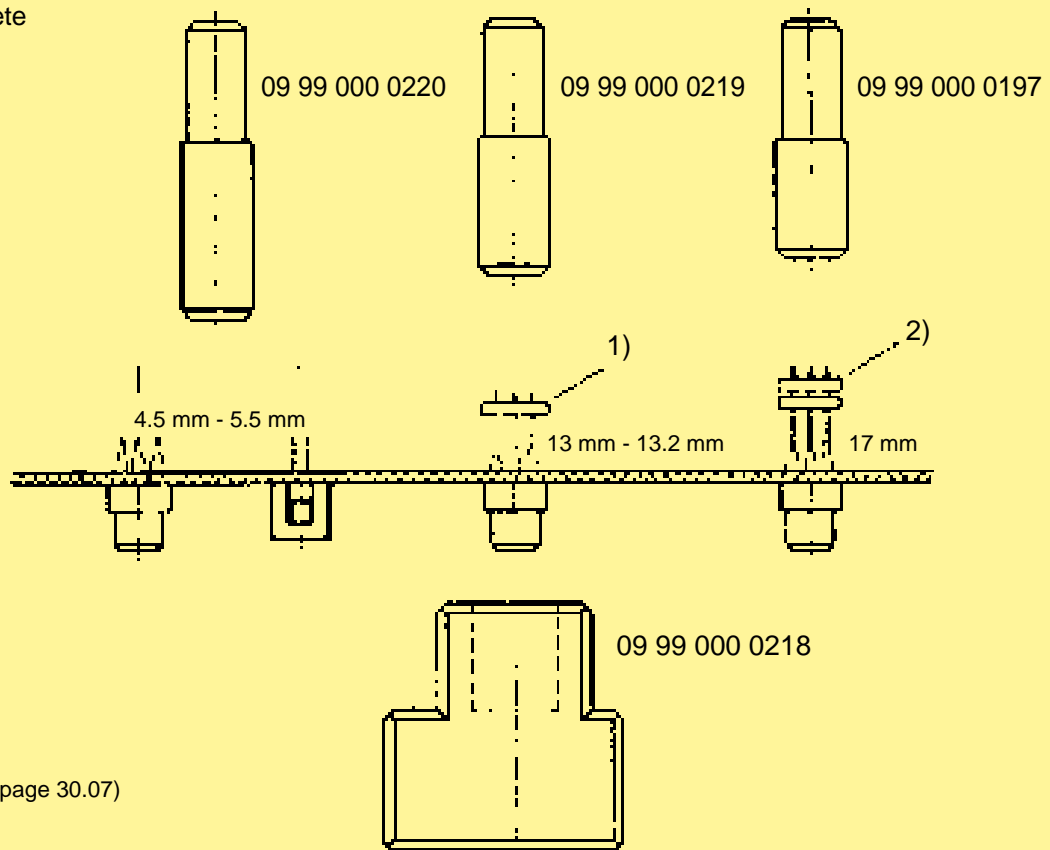

1) Termination support (see page 30.07)

2) for 17 mm wrap posts two termination supports are recommended

Identification	for use with	Part No.	Drawing	Dimensions in mm
Removal tool for moulding	Female connectors har-bus® 64	02 99 000 0003		
Removal tool (heavy duty) for moulding	Female connectors har-bus® 64	02 99 000 0006		
Press-out tool for 17 mm terminations	Female connectors har-bus® 64	02 99 000 0004		
Press-out tool for 5 mm / 4.5 mm terminations	Female connectors har-bus® 64	02 99 000 0008		
Support block	Female connectors har-bus® 64	02 99 000 0005		

Identification	for use with	Part No.	Drawing	Dimensions in mm
Removal tool for shroud	rear I/O shroud har-bus® 64	02 99 000 0007		
	rear I/O shroud Type C, 2C R, 2R	09 99 000 0278		

Replacement of complete **har-bus® 64** press-in connectors

Steps in detail

1. Lever up the moulding by using a removal tool
 - a) The removal tool with Part No. 02 99 000 0003 is suitable for repairing small quantities. It can only be used if the adjacent components on the pcb are at least 2 mm apart from the moulding of the connector.
 - b) The removal tool with Part No. 02 99 000 0006 is suitable for repairing large quantities. Due to its design it can also be used if components on the pcb are in close proximity to the moulding of the connector.

2. Lever up the rear I/O shroud with the removal tool 02 99 000 0007. This step is only required with 17 mm termination length.

3. Pull out the female contacts with the press-out tool
 - a) for 17 mm termination length use Part No. 02 99 000 0004 and
 - b) for 5 mm termination length use Part No. 02 99 000 0008.

During this process the press-out tool replaces the top tool and the pcb is supported by the support block (Part No. 02 99 000 0005) from the bottom.

Identification	Part No.	Drawing	Dimensions in mm
Hand bench press	09 99 000 0201		<p>Technical characteristics</p> <p>Working stroke 25 mm</p> <p>Press force 15 kN max.</p> <p>Hole \varnothing in the ram \varnothing 10 mm</p> <p>Net weight approx. 23 kg</p>
Pneumatic press 40 kN	09 99 000 0282		<p>Technical characteristics</p> <p>Total stroke 48 mm</p> <p>Working stroke 0-6 mm</p> <p>Press force 40 kN max.</p> <p>Air pressure 6 bar</p> <p>Hole \varnothing in the ram \varnothing 10.01 mm</p> <p>Net weight 136 kg</p> <p>Power supply 110 V / 220 V AC</p>
Adaptor for height compensation ¹⁾	09 99 000 0279		
Guide frame with base plate	09 99 000 0244		Standard type for pcb size x = 123,5 - 309,5 mm
	09 99 000 0261		Long type ²⁾ for pcb size x = 123,5 - 668,5 mm
Base plate	09 99 000 0255		

¹⁾ suitable for 09 99 000 0282 and all CPM machines (see page 30.12 ff.)

²⁾ not suitable for hand bench press



The **CPM prestige** press-in machine with a graphical user interface

The **CPM prestige** is a consequential development of the successful CPM 2001 press-in machines. The excellent design, supported by a wide range of tools presents a convenient, easy and comfortable way of processing backplanes and daughtercards. The machine is fully programmable and is supplied with a graphical user interface for control and visualisation of the complete process. The use of a microprocessor control allows the recognition and storage of different component heights, so that the pressing-in of different components is initiated simultaneously with only one button. The user-friendly touch-screen guides the user through the menu-orientated process controls.

The visualisation of the entire press-in process (the position of the connector, press-in forces etc.) allows the rapid recognition and eradication of the possible error sources. With the addition of a barcode reader (1D and 2D)¹⁾ the parameters of every pcb layout can be stored, recalled and loaded into the automated press-in programme. The extensive operation monitor functions simplify the service and support of the machine.

The machine employs the automatic switch-off system "autosense", known worldwide for its reliability. The different connector types and the tolerances of the pcb are automatically recognised and taken into consideration at the press-in operation, thus maximising the process security.

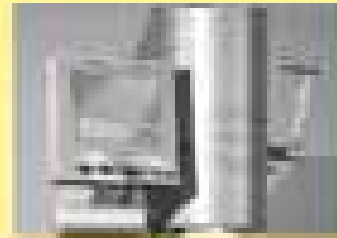

Visual guiding system via touch monitor

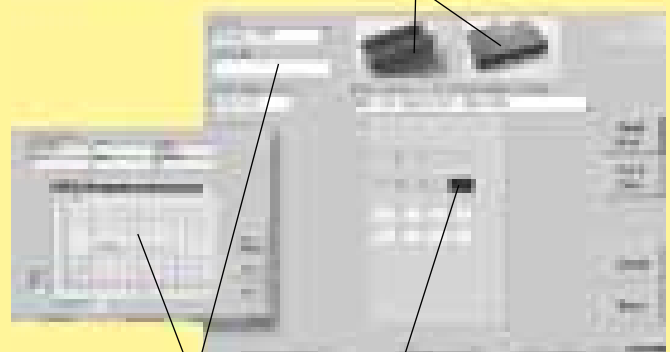

Real photos of connectors and tools

Process data

Layout with current position highlighted

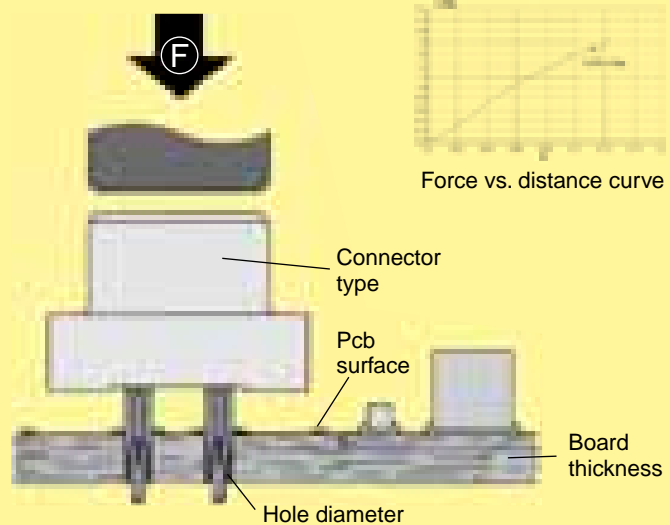

Shown are the four most considerable influences of the press-in process.

¹⁾ optional



Quality control of press-in termination

The press-in force correlates with the diameter of the plated through hole and with the friction coefficient of the surface; therefore it can be used for a continuous monitoring of the process.

The retention force, as an indirect measure of the normal force, serves to qualify the process or random tests.



CPM prestige

Part No. 09 89 040 0000

Technical characteristics

Drive	electro-mechanical, servo
Press-in force	100 kN
max. pcb dimensions	600 x 1000 mm
Floor space	1200 x 1150 mm
Weight	980 kg
Power supply	208 / 380 / 400 / 415 V
Consumption	< 1 kW
Colour	on request

CPM prestige
(incl. PC, control software, barcode reader, keyboard, touch screen)

Built-in features:

- Guiding rails (carbon/spring-loaded) for the secure positioning of the pcb
- Touch-screen and Industrial PC with UPS (uninterruptable power supply)
- Barcode reader for management ease of press-in programs
- All dimensions allow an easy integration into production lines

Process monitoring and quality assurance:

- Touch screen interface with graphical and verbal menus for all machine functions
- Autosense: automated press-in interruption at incorrect press-in forces
- Storage and validation of all press-in parameters via quality assurance software (press-in force tolerances)
- Continuous high-precision measurement and recording of press-in forces and distances
- Remote determination of errors and maintenance
- High flexibility through a modular tool range

Options:

- Rotatable tool changer
- Insertion removal station

Insertion removal station



Power supply 220 V / 50 Hz
 Air pressure 6 bar (15-16 l/min.)

Part No. **09 89 040 3000**
 for pcb dimensions
 of max.
 710 mm x 540 mm

Bestseller **CPM prestige** with insertion removal station, adaptable to all HARTING press-in machines.

Principle:

①

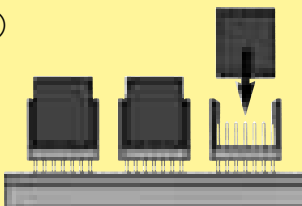

Load all headers with inserts for **one press-in cycle**

②

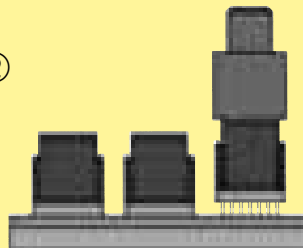

Press-in all connectors with a flat die

③

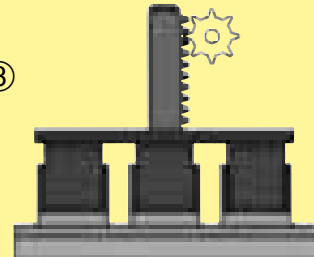

Position the magnetic plate

④

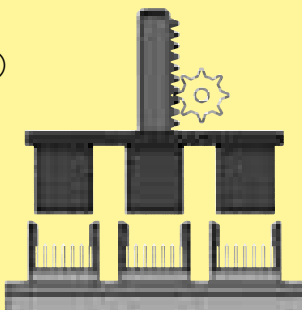

Remove all press-in inserts in one operation

Remove the processed pcb from the machine

⑤

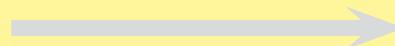

⑥

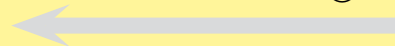

Move the next pre-assembled pcb to the press-in machine

⑦

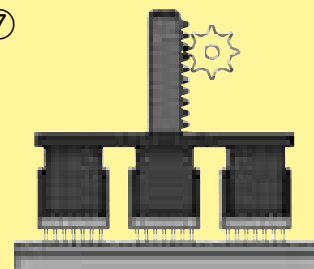

Load all headers in one operation

Today nearly all female connectors are designed for flat rock tooling. For every type of male connector specific tooling and a high degree of X-Y-process accuracy is required. Therefore HARTING offers press-in insert blocks that transfer all well known assembling advantages from female connectors to male headers.



Advantages of press inserts

Robust tooling

No lateral force to pcb hole

No abrasion of the contact mating surface by the press tool

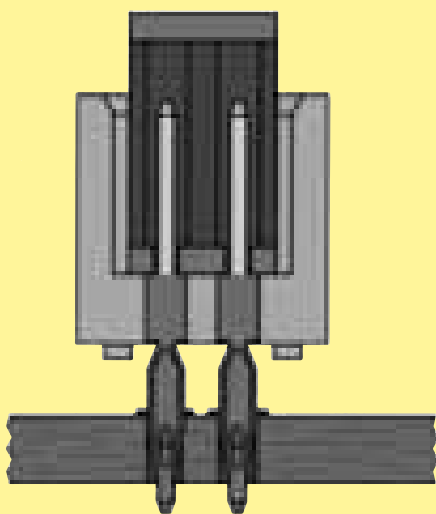

HARTING has already developed press-in inserts for all major male connector families on 2.54 mm, 2.5 mm and 2 mm pitches.







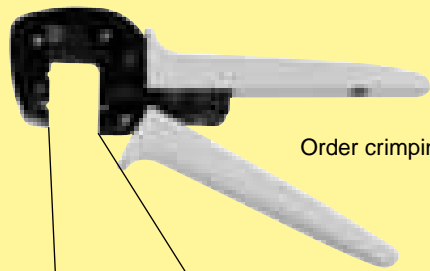
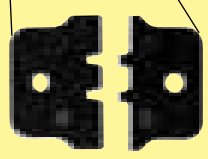

Inserts for any other special components can be developed on request.

The additional process for inserting and removing the press-in inserts can be efficiently done with the insertion removal station. This station removes all press-in inserts with a magnetic plate in one operation and inserts them into the next pre-assembled pcb with the necessary precision. (Principle see page 30.14).

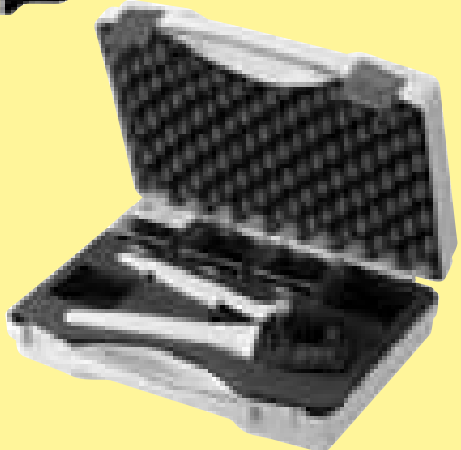
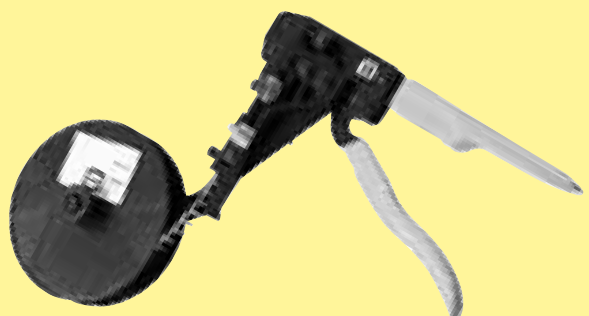

The cycle time for loading all headers is between 4 and 6 seconds, independent from the amount of press-in inserts.

To load the inserts automatically means also that connectors assembled in a wrong way will be recognised and errors consequently prevented.



Identification	Part No.	Drawing	Dimensions in mm
HARTING crimping tool for individual contacts BC / FC and har-bus® 64	09 99 000 0620		Order crimping inserts separately
Crimping insert set for individual contacts each set contains locator and crimp insert top and bottom part			
BC / FC 1 / har-bus® 64	09 99 000 0621	Wire gauge	BC: 0.09 - 0.50 mm ²
FC 2	09 99 000 0622		FC 1: 0.09 - 0.25 mm ²
FC 3	09 99 000 0623		FC 2: 0.14 - 0.56 mm ²
BC / har-bus® 64 solid wire	09 99 000 0629		FC 3: 0.50 - 1.50 mm ²
			BC: 0.13 mm ² (solid wire)
Locator BC / har-bus® 64 FC	09 99 000 0630 09 99 000 0631		
Service case for crimping tool and 5 sets inserts, incl. screwdriver for insert change, without contents	09 99 000 0632		
HARTING crimping tool for bandoliered contacts (500 pieces) BC / har-bus® 64	09 99 000 0248		Wire gauge 0.09 - 0.5 mm ²
for bandoliered contacts (250 pieces)			Wire gauge
FC 1	09 99 000 0247		0.09 - 0.25 mm ²
FC 2	09 99 000 0119		0.14 - 0.56 mm ²
FC 3	09 99 000 0120		0.50 - 1.50 mm ²
BC / har-bus® 64 solid wire	09 99 000 0627		0.13 mm ² (solid wire)
Crimping tool for individual contacts FC 1, FC 2 and FC 3 (Service tool)	09 99 000 0191		Wire gauge FC 1: 0.14 - 0.25 mm ² FC 2: 0.25 - 0.56 mm ² FC 3: 0.75 - 1.50 mm ² Locator is supplied with the tool.
Insertion tool for contacts BC / har-bus® 64	09 99 000 0100		
for contacts FC 1, FC 2 and FC 3	09 99 000 0088		
Removal tool for contacts BC / har-bus® 64	09 99 000 0101		
for contacts FC 1, FC 2 and FC 3	09 99 000 0087		

Tooling

Identification	Part No.	Drawing	Dimensions in mm
<p>HARTING semi-automatic crimping device</p> <p>Main drive, foot-operated 115/230 V – 50 Hz</p>	<p>09 99 000 0246</p>	 <p>Locator not necessary</p>	
<p>Crimping head for bandoliered contacts BC / har-bus® 64</p> <p>FC 1 FC 2 FC 3</p> <p>BC/har-bus® 64 solid wire</p> <p>Real holder for 2,500 contacts FC 1, FC 2 or FC 3 and for 5,000 contacts BC / har-bus® 64</p>	<p>09 99 000 0252</p> <p>09 99 000 0249 09 99 000 0250 09 99 000 0251</p> <p>09 99 000 0628</p> <p>09 99 000 0158</p>	<p>Wire gauge 0.09 - 0.5 mm²</p> <p>0.09 - 0.25 mm² 0.14 - 0.56 mm² 0.5 - 1.5 mm²</p> <p>0.13 mm² (solid wire)</p> 	

Automated crimping machine type BK



Main characteristics

- Smooth run through electronic brakes
- Hand wheel for manual adjustments
- Maintenance friendly through needle bearing rail
- Simple handling by quick change tool and stripper

Part No. 09 98 000 5000

Technical Characteristics

Dimensions

Height 690 mm
(1400 mm with a contact reel)

Width 350 mm

Depth 370 mm

Total weight 72 kg

Power supply 230 V, 50/60 Hz, 2.5 A

Consumption 0.75 kW

Motor speed 440 - 2000 rpm

Cable length 2 m incl. plug

Control SPS

Work cycle trigger Sensor

Work cycle 0.35 s for stripping and crimping

Illumination Integrated tool light

Stroke counter Daywise and fixed

Crimp force monitor BB07i

Crimping tool Quick change tool

Adjustable process parameters
 Crimping height on wire
 Crimping height on insulation
 Depth of insulation stripping
 Length of insulation stripping
 Wire retainer position
 Wire position in the crimp contact
 Band thrust



Identification	for use with	Part No.	Wire gauge [mm ²]	AWG	Insulation [Ø mm]	
Crimping tool for DIN 41 612 connectors ¹⁾	contacts BC / har-bus® 64	09 98 000 3004	0.09 - 0.56	28 - 20	0.7 - 1.6	
	contacts FC 1	09 98 000 3005	0.09 - 0.25	28 - 24	0.7 - 1.6	
	FC 2	09 98 000 3006	0.14 - 0.56	26 - 20	0.8 - 2.3	
	FC 3	09 98 000 3007	0.50 - 1.50	20 - 16	1.6 - 2.8	
	for D-Sub connectors ²⁾	standard contacts	09 98 000 3008 09 98 000 3009	0.09 - 0.25 0.25 - 0.56	28 - 24 24 - 20	0.7 - 1.4 0.9 - 1.7
		high density contacts	09 98 000 3012		26 - 24	0.8 - 1.4

¹⁾ 3.5 + 0.5 mm of insulation is stripped from the wire to be crimped

²⁾ 2.5 + 0.5 mm of insulation is stripped from the wire to be crimped

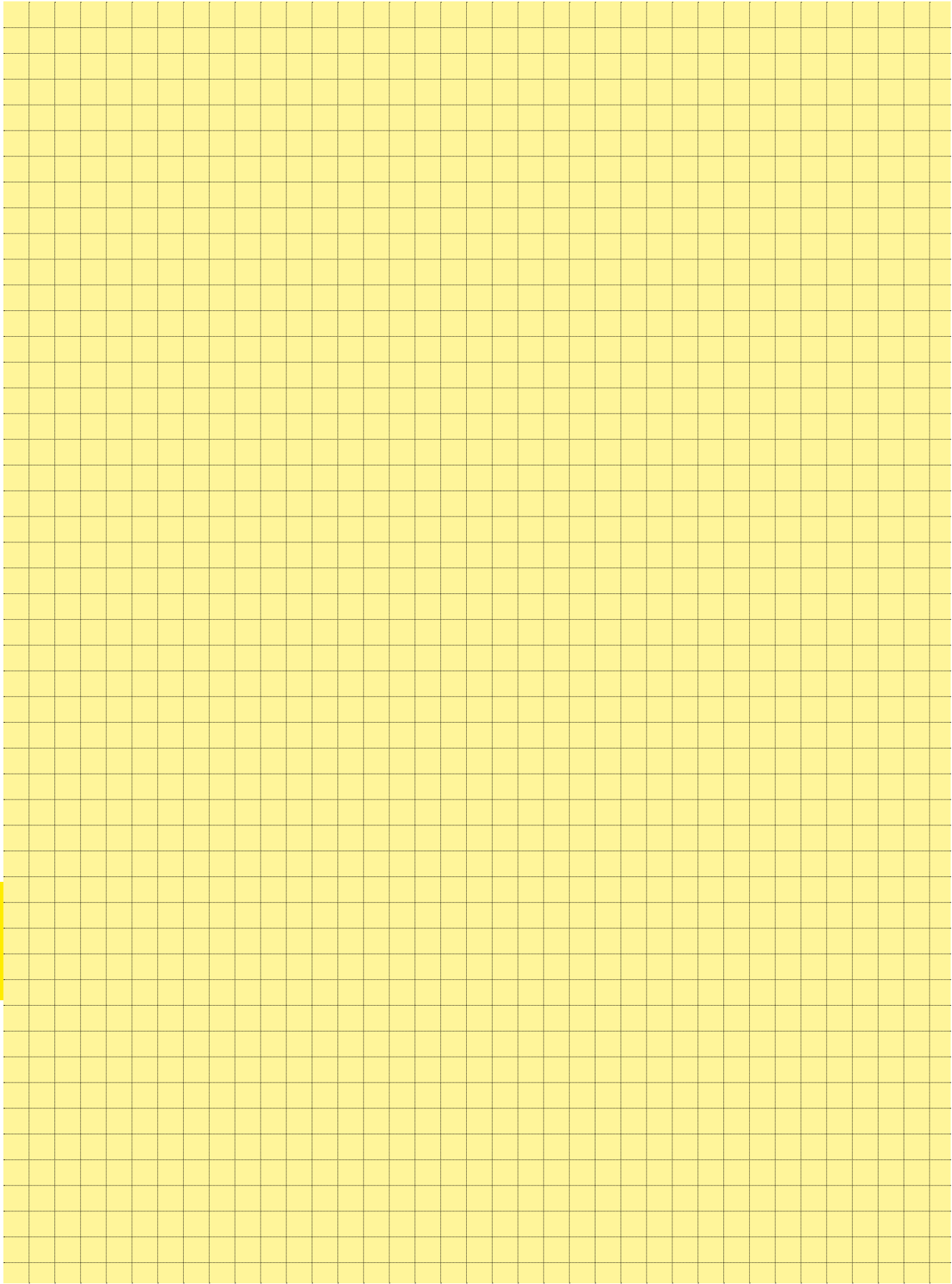

Tooling

30
-
20

List of part numbers



Part No.	Page	Part No.	Page	Part No.	Page	Part No.	Page	Part No.	Page
02 01 160 1101	02.11	02 09 000 0012	02.16	09 02 000 9902	00.10	09 02 000 9954	20.06	09 02 264 6861	01.12
02 01 160 1102	02.11	02 09 000 0012	30.06	09 02 000 9902	01.60	09 02 000 9954	20.09	09 02 264 6870	01.12
02 01 160 1105	02.11			09 02 000 9902	01.61			09 02 264 7828	01.14
02 01 160 1106	02.11			09 02 000 9902	02.17				
				09 02 000 9902	03.20	09 02 064 0501	00.08		
02 01 160 2101	02.05			09 02 000 9902	03.25	09 02 064 0501	20.02	09 02 332 6931	01.11
02 01 160 2101	02.11	02 44 000 0001	02.05	09 02 000 9902	20.02	09 02 064 0501	20.04		
02 01 160 2102	02.11	02 44 000 0001	02.16	09 02 000 9902	20.06	09 02 064 0501	20.05		
		02 44 000 0002	02.16	09 02 000 9903	00.08	09 02 064 0501	20.07	09 02 364 6921	01.11
		02 44 000 0003	02.16	09 02 000 9903	00.09	09 02 064 0502	00.08		
		02 44 000 0004	02.16	09 02 000 9903	00.10	09 02 064 0502	20.02		
		02 44 000 0005	02.16	09 02 000 9903	01.60	09 02 064 0502	20.04	09 02 464 6824	01.12
02 02 160 1201	02.12	02 44 000 0006	02.16	09 02 000 9903	01.61	09 02 064 0502	20.05	09 02 464 6825	01.12
02 02 160 1202	02.12	02 44 000 0007	02.16	09 02 000 9903	02.17	09 02 064 0502	20.07		
02 02 160 1301	02.12	02 44 000 0007	02.17	09 02 000 9903	03.20				
02 02 160 1302	02.12	02 44 000 0007	02.18	09 02 000 9903	03.25	09 02 064 3214	01.15	09 02 632 6921	01.11
02 02 160 1601	02.12	02 44 000 0008	02.16	09 02 000 9903	20.02				
		02 44 000 0008	02.17	09 02 000 9903	20.06	09 02 132 2921	01.11	09 02 664 6921	01.11
02 02 160 2201	02.05	02 44 000 0009	00.09	09 02 000 9903	00.08	09 02 132 2931	01.11		
02 02 160 2201	02.12	02 44 000 0009	02.16	09 02 000 9909	00.09	09 02 132 6921	01.11		
02 02 160 2202	02.12	02 44 000 0009	02.17	09 02 000 9909	00.11	09 02 132 6922	01.11	09 02 764 6824	01.12
02 02 160 2301	02.05			09 02 000 9909	20.02	09 02 132 6931	01.11	09 02 764 6825	01.12
02 02 160 2301	02.12			09 02 000 9909	20.07	09 02 132 6932	01.11		
02 02 160 2301	02.17			09 02 000 9910	20.02	09 02 132 7921	01.11		
02 02 160 2301	02.18			09 02 000 9910	20.07	09 02 132 7922	01.11		
02 02 160 2302	02.12	02 99 000 0001	30.05	09 02 000 9911	20.02	09 02 132 7931	01.11	09 03 000 6101	01.37
		02 99 000 0002	30.06	09 02 000 9911	20.07			09 03 000 6101	01.40
		02 99 000 0003	30.09	09 02 000 9919	00.09			09 03 000 6102	01.37
		02 99 000 0003	30.10	09 02 000 9919	20.02	09 02 164 2921	01.11	09 03 000 6102	01.40
		02 99 000 0004	30.09	09 02 000 9919	20.06	09 02 164 2922	01.11	09 03 000 6103	01.37
02 03 160 2201	02.05	02 99 000 0004	30.10	09 02 000 9919	20.09	09 02 164 2952	01.11	09 03 000 6103	01.40
02 03 160 2201	02.13	02 99 000 0005	30.09	09 02 000 9920	00.09	09 02 164 6919	01.11	09 03 000 6104	01.37
		02 99 000 0005	30.10	09 02 000 9920	20.02	09 02 164 6920	01.11	09 03 000 6104	01.40
		02 99 000 0006	30.09	09 02 000 9920	20.06	09 02 164 6921	01.11	09 03 000 6110	01.37
		02 99 000 0006	30.10	09 02 000 9920	20.09	09 02 164 6921 222	01.11	09 03 000 6110	01.40
		02 99 000 0007	30.10	09 02 000 9920	00.09	09 02 164 6922	01.11	09 03 000 6111	01.37
02 04 160 1101	02.05	02 99 000 0008	30.09	09 02 000 9921	20.02	09 02 164 6951	01.11	09 03 000 6111	01.40
02 04 160 1101	02.14	02 99 000 0008	30.10	09 02 000 9921	20.06	09 02 164 6952	01.11	09 03 000 6113	01.37
		02 99 000 0016	30.06	09 02 000 9921	20.09	09 02 164 6952	01.11	09 03 000 6113	01.40
				09 02 000 9922	00.09	09 02 164 7919	01.11	09 03 000 6114	01.37
				09 02 000 9922	20.02	09 02 164 7921	01.11	09 03 000 6114	01.40
				09 02 000 9922	20.06	09 02 164 7922	01.11	09 03 000 6115	01.37
02 05 000 0003	02.15			09 02 000 9922	20.09			09 03 000 6115	01.40
02 05 000 0004	02.15			09 02 000 9926	20.02			09 03 000 6122	01.37
02 05 000 0004	02.17	09 02 000 6474	01.15	09 02 000 9926	20.07	09 02 264 2824	01.12	09 03 000 6122	01.40
02 05 000 0004	02.18	09 02 000 6474	01.27	09 02 000 9926	20.09	09 02 264 2825	01.12	09 03 000 6127	01.37
02 05 000 0005	02.15	09 02 000 6484	01.15	09 02 000 9926	20.02	09 02 264 2850	01.12	09 03 000 6127	04.24
		09 02 000 6484	01.27	09 02 000 9927	20.07			09 03 000 6128	01.37
02 05 000 1511	02.15	09 02 000 8434	01.15	09 02 000 9927	20.09	09 02 264 6421	01.12	09 03 000 6128	04.24
02 05 000 1512	02.15	09 02 000 8434	01.27	09 02 000 9928	00.14	09 02 264 6821	01.12	09 03 000 6128	01.37
02 05 000 1513	02.15	09 02 000 8444	01.15	09 02 000 9928	00.06	09 02 264 6823	01.12	09 03 000 6133	01.37
		09 02 000 8444	01.27	09 02 000 9935	01.13	09 02 264 6824	01.12	09 03 000 6133	01.40
02 05 000 2511	02.15	09 02 000 8474	01.15	09 02 000 9939	01.61	09 02 264 6825	01.12	09 03 000 6134	01.37
02 05 000 2512	02.15	09 02 000 8474	01.27	09 02 000 9953	01.61	09 02 264 6825 222	01.12	09 03 000 6134	01.40
02 05 000 2513	02.15	09 02 000 8484	01.15	09 02 000 9953	20.02	09 02 264 6828	01.14	09 03 000 6140	01.36
		09 02 000 8484	01.27	09 02 000 9953	20.06	09 02 264 6829	01.12	09 03 000 6140	01.39
				09 02 000 9901	00.16	09 02 264 6841	01.12	09 03 000 6160	01.36
02 07 160 1101	02.05	09 02 000 9902	00.08	09 02 000 9953	20.09	09 02 264 6850	01.12	09 03 000 6160	01.38
02 07 160 1101	02.14	09 02 000 9902	00.09	09 02 000 9954	01.61	09 02 264 6850 222	01.12	09 03 000 6161	01.36

List of part numbers



Part No.	Page	Part No.	Page	Part No.	Page	Part No.	Page	Part No.	Page
09 03 000 6161	01.38	09 03 000 9940	01.26	09 03 160 2901	01.41	09 03 232 2824	01.22	09 03 264 7828	01.26
09 03 000 6165	01.36	09 03 000 9950	01.58	09 03 160 6901	01.41	09 03 232 2825	01.22	09 03 264 7845	01.22
09 03 000 6165	01.38	09 03 000 9951	01.58			09 03 232 2845	01.22	09 03 264 7850	01.24
09 03 000 6167	01.36	09 03 000 9952	01.58	09 03 160 7901	01.41	09 03 232 2850	01.24	09 03 264 7855	01.22
09 03 000 6181	01.36	09 03 000 9953	01.58			09 03 232 2855	01.22		
09 03 000 6181	01.38	09 03 000 9953	01.60						
09 03 000 6182	01.36	09 03 000 9954	01.58	09 03 164 2919	01.20	09 03 232 6421	01.22	09 03 278 6804	01.42
09 03 000 6182	01.38	09 03 000 9955	01.58	09 03 164 2921	01.20	09 03 232 6824	01.22	09 03 278 6805	01.42
09 03 000 6201	01.37	09 03 000 9956	01.58	09 03 164 2921 222	01.20	09 03 232 6825	01.22	09 03 278 6805 222	01.42
09 03 000 6201	01.40	09 03 000 9957	01.58	09 03 164 2922	01.20	09 03 232 6845	01.22	09 03 278 6830	01.43
09 03 000 6202	01.37	09 03 000 9957	01.60	09 03 164 2922	01.20	09 03 232 6850	01.24	09 03 278 6850	01.42
09 03 000 6202	01.40	09 03 000 9958	01.58	09 03 164 2951	01.20	09 03 232 6855	01.22	09 03 278 6864	01.43
09 03 000 6203	01.37	09 03 000 9959	01.58	09 03 164 6918	01.20	09 03 232 7824	01.22	09 03 278 6865	01.43
09 03 000 6203	01.40	09 03 000 9960	01.58	09 03 164 6919	01.20	09 03 232 7825	01.22		
09 03 000 6213	01.37	09 03 000 9961	01.58	09 03 164 6921	01.20	09 03 232 7845	01.22		
09 03 000 6213	01.40	09 03 000 9962	01.58	09 03 164 6921 222	01.20	09 03 232 7855	01.22	09 03 296 2824	01.22
09 03 000 6214	01.37	09 03 000 9963	01.58	09 03 164 6922	01.20			09 03 296 2824 222	01.22
09 03 000 6214	01.40	09 03 000 9964	01.58	09 03 164 6951	01.20			09 03 296 2825	01.22
09 03 000 6215	01.37	09 03 000 9965	01.58			09 03 242 6804	01.42	09 03 296 2825 222	01.22
09 03 000 6215	01.40	09 03 000 9966	01.58	09 03 164 7921	01.20	09 03 242 6805	01.42	09 03 296 2845	01.22
09 03 000 6220	01.37	09 03 000 9967	01.58	09 03 164 7922	01.20	09 03 242 6830	01.43	09 03 296 2850	01.24
09 03 000 6220	04.25	09 03 000 9968	01.58	09 03 164 7951	01.20	09 03 242 6850	01.42	09 03 296 2850 222	01.24
09 03 000 6225	01.37	09 03 000 9969	01.58			09 03 242 6864	01.43	09 03 296 2855	01.22
09 03 000 6225	01.40			09 03 178 2901	01.41	09 03 242 6865	01.43	09 03 296 6421	01.22
09 03 000 6240	01.36							09 03 296 6821	01.25
09 03 000 6240	01.39	09 03 096 0501	00.08	09 03 178 6901	01.41	09 03 260 6804	01.42	09 03 296 6823	01.25
09 03 000 6245	01.37	09 03 096 0501	00.09	09 03 178 6901 222	01.41	09 03 260 6805	01.42	09 03 296 6824	01.22
09 03 000 6245	01.40	09 03 096 0501	00.10			09 03 260 6830	01.43	09 03 296 6824 222	01.22
09 03 000 6250	01.37	09 03 096 0501	01.60	09 03 178 7901	01.41	09 03 260 6850	01.42	09 03 296 6825	01.22
09 03 000 6250	01.40	09 03 096 0501	01.61			09 03 260 6864	01.43	09 03 296 6825 222	01.22
09 03 000 6260	01.36	09 03 096 0501	03.25			09 03 260 6865	01.43	09 03 296 6829	01.22
09 03 000 6260	01.38	09 03 096 0501	20.02	09 03 196 2919	01.20			09 03 296 6841	01.22
09 03 000 6261	01.36	09 03 096 0501	20.04	09 03 196 2921	01.20			09 03 296 6845	01.22
09 03 000 6261	01.38	09 03 096 0501	20.05	09 03 196 2921 222	01.20	09 03 264 2824	01.22	09 03 296 6845	01.61
09 03 000 6262	01.36	09 03 096 0501	20.07	09 03 196 2922	01.20	09 03 264 2824 222	01.22	09 03 296 6845	01.62
09 03 000 6262	01.38			09 03 196 2951	01.20	09 03 264 2825	01.22	09 03 296 6850	01.24
09 03 000 6263	01.36	09 03 096 3214	01.27			09 03 264 2845	01.22	09 03 296 6850	01.62
09 03 000 6263	01.38	09 03 096 3214	01.60	09 03 196 6919	01.20	09 03 264 2850	01.24	09 03 296 6850	02.05
09 03 000 6269	01.36	09 03 096 3217	01.27	09 03 196 6920	01.20			09 03 296 6850 222	01.24
09 03 000 6269	01.38	09 03 096 3217	01.61	09 03 196 6921	01.20	09 03 264 6421	01.22	09 03 296 6851	01.24
09 03 000 6274	01.36			09 03 196 6921	01.61	09 03 264 6821	01.25	09 03 296 6852	01.24
09 03 000 6274	01.38			09 03 196 6921	01.62	09 03 264 6823	01.25	09 03 296 6855	01.22
09 03 000 6281	01.36	09 03 124 2901	01.41	09 03 196 6921 222	01.20	09 03 264 6824	01.22	09 03 296 6861	01.24
09 03 000 6281	01.38	09 03 124 6901	01.41	09 03 196 6922	01.20	09 03 264 6824 222	01.22	09 03 296 6861	01.60
		09 03 124 6901 222	01.41	09 03 196 6951	01.20	09 03 264 6825	01.22	09 03 296 6862	01.24
09 03 000 9913	00.09					09 03 264 6828	01.26	09 03 296 6862	01.60
09 03 000 9913	01.58	09 03 124 7901	01.41	09 03 196 7921	01.20	09 03 264 6828	01.60	09 03 296 6878	01.25
09 03 000 9913	01.60			09 03 196 7922	01.20	09 03 264 6829	01.22		
09 03 000 9913	02.17			09 03 196 7951	01.20	09 03 264 6829	01.22	09 03 296 7824	01.22
09 03 000 9914	01.58					09 03 264 6841	01.22	09 03 296 7825	01.22
09 03 000 9914	01.60	09 03 132 2921	01.20			09 03 264 6845	01.22	09 03 296 7845	01.22
09 03 000 9914	03.19	09 03 132 6921	01.20	09 03 224 6804	01.42	09 03 264 6850	01.24	09 03 296 7850	01.24
09 03 000 9914	03.20			09 03 224 6805	01.42	09 03 264 6850 222	01.24	09 03 296 7855	01.22
09 03 000 9921	01.58			09 03 224 6805 222	01.42	09 03 264 6851	01.24		
09 03 000 9921	01.60			09 03 224 6830	01.43	09 03 264 6855	01.22		
09 03 000 9921	03.19	09 03 142 2901	01.41	09 03 224 6850	01.42	09 03 264 6861	01.24	09 03 332 2921	01.20
09 03 000 9921	03.20			09 03 224 6864	01.43	09 03 264 6878	01.25		
09 03 000 9939	01.25	09 03 142 6901	01.41	09 03 224 6864 222	01.43	09 03 264 7824	01.22	09 03 332 6921	01.20
09 03 000 9940	01.14	09 03 142 7901	01.41	09 03 224 6865	01.43	09 03 264 7825	01.22	09 03 332 7921	01.20

List of part numbers



Part No.	Page	Part No.	Page	Part No.	Page	Part No.	Page	Part No.	Page
09 03 364 2921	01.20	09 03 796 6421	01.22	09 04 232 7831	03.12	09 05 148 7921	03.15	09 06 000 6474	03.17
09 03 364 6919	01.20	09 03 796 6821	01.25	09 04 232 7832	03.12	09 05 148 7931	03.15	09 06 000 6474	03.31
09 03 364 6921	01.20	09 03 796 6823	01.25					09 06 000 6481	03.14
		09 03 796 6824	01.22					09 06 000 6481	03.17
09 03 364 7921	01.20	09 03 796 6825	01.22	09 04 332 6831	03.12	09 05 248 2821	03.18	09 06 000 6481	03.31
		09 03 796 6825 222	01.22	09 04 332 6919	03.11	09 05 248 2823	03.18	09 06 000 6482	03.14
		09 03 796 6850	01.24	09 04 332 6921	03.11	09 05 248 2831	03.18	09 06 000 6482	03.17
09 03 378 2901	01.41	09 03 796 6850 222	01.24			09 05 248 2831 222	03.18	09 06 000 6482	03.31
09 03 378 6901	01.41			09 04 532 3213	03.14	09 05 248 2832	03.18	09 06 000 6484	03.14
						09 05 248 2851	03.18	09 06 000 6484	03.17
						09 05 248 6821	03.18	09 06 000 6484	03.31
09 03 396 2919	01.20	09 04 000 9906	03.24	09 04 632 2951	03.11	09 05 248 6823	03.18	09 06 000 7471	03.14
09 03 396 2921	01.20	09 04 000 9906	20.02			09 05 248 6831	03.18	09 06 000 7471	03.17
09 03 396 6918	01.20	09 04 000 9907	03.24	09 04 632 6921	03.11	09 05 248 6832	03.18	09 06 000 7471	03.31
09 03 396 6919	01.20	09 04 000 9907	20.02	09 04 632 6951	03.11	09 05 248 6851	03.18	09 06 000 7472	03.14
09 03 396 6921	01.20	09 04 000 9908	00.16			09 05 248 6851	03.20	09 06 000 7472	03.17
09 03 396 6951	01.20					09 05 248 6851 222	03.18	09 06 000 7472	03.31
09 03 396 7921	01.20			09 04 732 6821	03.12	09 05 248 7821	03.18	09 06 000 7474	03.14
		09 04 016 3201	00.08	09 04 732 6831	03.12	09 05 248 7823	03.18	09 06 000 7474	03.17
		09 04 016 3201	00.09	09 04 732 6832	03.12	09 05 248 7832	03.18	09 06 000 7474	03.31
09 03 464 2824	01.22	09 04 016 3201	00.10					09 06 000 7481	03.14
09 03 464 6824	01.22	09 04 016 3201	03.23					09 06 000 7481	03.17
09 03 464 6825	01.22					09 05 348 6831	03.18	09 06 000 7481	03.31
						09 05 348 6921	03.15	09 06 000 7482	03.14
09 03 464 7825	01.22	09 04 032 3213	03.14	09 05 000 9912	03.19			09 06 000 7482	03.17
		09 04 032 3215	00.08	09 05 000 9912	03.20			09 06 000 7482	03.31
		09 04 032 3215	00.09	09 05 000 9914	03.19			09 06 000 7482	03.31
09 03 496 2824	01.22	09 04 032 3215	00.10	09 05 000 9922	03.19	09 05 548 3202	03.17	09 06 000 7484	03.14
09 03 496 6824	01.22	09 04 032 3215	00.10	09 05 000 9924	03.19			09 06 000 7484	03.17
09 03 496 6825	01.22							09 06 000 7484	03.31
09 03 496 7825	01.22			09 05 048 0501	00.09	09 05 648 2921	03.15	09 06 000 8471	03.14
		09 04 132 2921	03.11	09 05 048 0501	00.10	09 05 648 6921	03.15	09 06 000 8471	03.17
		09 04 132 2921 222	03.11	09 05 048 0501	02.17	09 05 648 6931	03.15	09 06 000 8471	03.31
				09 05 048 0501	03.20			09 06 000 8472	03.14
09 03 596 3214	01.27	09 04 132 6921	03.11	09 05 048 0501	03.25	09 05 748 2831	03.18	09 06 000 8472	03.17
		09 04 132 6921 222	03.11	09 05 048 0501	20.02			09 06 000 8472	03.31
		09 04 132 6922	03.11	09 05 048 0501	20.04	09 05 748 6831	03.18	09 06 000 8474	03.14
09 03 664 2921	01.20	09 04 132 6951	03.11	09 05 048 0501	20.05			09 06 000 8474	03.17
09 03 664 6921	01.20	09 04 132 6952	03.11	09 05 048 0501	20.07			09 06 000 8474	03.31
		09 04 132 7921	03.11	09 05 048 3202	03.17	09 06 000 5541	03.40	09 06 000 8481	03.14
09 03 696 2921	01.20			09 05 048 3202	03.20	09 06 000 5542	03.40	09 06 000 8481	03.17
09 03 696 6919	01.20	09 04 232 2821	03.12	09 05 048 3204	00.09			09 06 000 8482	03.14
09 03 696 6921	01.20	09 04 232 2823	03.12	09 05 048 3204	00.10	09 06 000 6420	03.14	09 06 000 8482	03.17
09 03 696 6921 222	01.20	09 04 232 2826	03.13	09 05 048 3204	03.23	09 06 000 6420	03.17	09 06 000 8482	03.31
		09 04 232 2831	03.12			09 06 000 6420	03.31	09 06 000 8482	03.31
		09 04 232 2831 222	03.12	09 05 048 6924	00.09	09 06 000 6451	03.24	09 06 000 8484	03.14
09 03 732 6421	01.22	09 04 232 2832	03.12	09 05 048 6924	03.16	09 06 000 6452	03.24	09 06 000 8484	03.17
						09 06 000 6454	03.24	09 06 000 8484	03.31
		09 04 232 6821	03.12			09 06 000 6461	03.24	09 06 000 9541	03.40
09 03 764 6421	01.22	09 04 232 6823	03.12	09 05 148 2921	03.15	09 06 000 6462	03.24	09 06 000 9542	03.40
09 03 764 6821	01.25	09 04 232 6826	03.13	09 05 148 2921 222	03.15	09 06 000 6464	03.24	09 06 000 9544	03.40
09 03 764 6823	01.25	09 04 232 6826 222	03.13	09 05 148 2931	03.15	09 06 000 6471	03.14	09 06 000 9551	03.40
09 03 764 6824	01.22	09 04 232 6831	03.12			09 06 000 6471	03.17	09 06 000 9552	03.40
09 03 764 6825	01.22	09 04 232 6831 222	03.12	09 05 148 6920	03.15	09 06 000 6471	03.31	09 06 000 9554	03.40
09 03 764 6828	01.26	09 04 232 6832	03.12	09 05 148 6921	03.15	09 06 000 6472	03.14	09 06 000 9561	03.40
				09 05 148 6921 222	03.15	09 06 000 6472	03.17	09 06 000 9562	03.40
		09 04 232 7821	03.12	09 05 148 6931	03.15	09 06 000 6472	03.31	09 06 000 9564	03.40
09 03 796 2825	01.22	09 04 232 7823	03.12	09 05 148 6951	03.15	09 06 000 6474	03.14	09 06 000 9571	03.40
				09 05 148 6961	03.15				

List of part numbers



Part No.	Page	Part No.	Page	Part No.	Page	Part No.	Page	Part No.	Page
09 06 000 9572	03.40	09 06 000 9917	20.15	09 06 000 9986	20.22	09 06 015 2813	04.13	09 06 048 0504	00.11
09 06 000 9574	03.40	09 06 000 9919	00.11	09 06 000 9987	20.03	09 06 015 2813	20.21	09 06 048 0504	20.02
09 06 000 9901	00.11	09 06 000 9919	20.02	09 06 000 9987	20.22	09 06 015 2912	04.11	09 06 048 0504	20.12
09 06 000 9901	20.02	09 06 000 9919	20.14	09 06 000 9988	20.03	09 06 015 2913	04.11	09 06 048 0504	20.13
09 06 000 9901	20.11	09 06 000 9920	20.22	09 06 000 9988	20.22	09 06 015 2914	04.11	09 06 048 0504	20.14
09 06 000 9902	00.11	09 06 000 9926	00.11	09 06 000 9989	20.03	09 06 015 2922	04.11	09 06 048 0504	20.15
09 06 000 9902	20.02	09 06 000 9926	20.02	09 06 000 9989	20.22	09 06 015 2931	04.11	09 06 048 0505	00.09
09 06 000 9902	20.11	09 06 000 9926	20.03	09 06 000 9992	20.20			09 06 048 0505	00.10
09 06 000 9905	00.11	09 06 000 9926	20.14	09 06 000 9993	20.20			09 06 048 0505	00.11
09 06 000 9905	20.02	09 06 000 9926	20.17	09 06 000 9995	20.03	09 06 016 3301	03.36	09 06 048 0505	20.02
09 06 000 9905	20.11	09 06 000 9929	20.02	09 06 000 9995	20.24	09 06 016 3302	03.36	09 06 048 0505	20.12
09 06 000 9906	00.11	09 06 000 9929	20.15	09 06 000 9995	20.25			09 06 048 0505	20.13
09 06 000 9906	20.02	09 06 000 9930	00.09	09 06 000 9996	20.03	09 06 024 3202	03.39	09 06 048 0505	20.14
09 06 000 9906	20.11	09 06 000 9930	00.10	09 06 000 9996	20.24			09 06 048 0505	20.15
09 06 000 9907	00.11	09 06 000 9930	00.11	09 06 000 9996	20.25			09 06 048 0515	00.09
09 06 000 9907	20.02	09 06 000 9930	20.03	09 06 000 9997	20.03	09 06 031 2921	04.22	09 06 048 0515	00.10
09 06 000 9907	20.03	09 06 000 9930	20.19	09 06 000 9997	20.24	09 06 031 6921	04.22	09 06 048 0515	00.11
09 06 000 9907	20.14	09 06 000 9933	00.10	09 06 000 9997	20.25	09 06 031 6923	04.22	09 06 048 0515	20.03
09 06 000 9907	20.18	09 06 000 9933	00.11	09 06 000 9998	20.03			09 06 048 0515	20.16
09 06 000 9907	20.24	09 06 000 9933	20.02	09 06 000 9998	20.24			09 06 048 0515	20.17
09 06 000 9907	20.25	09 06 000 9933	20.03					09 06 048 0521	00.09
09 06 000 9908	00.11	09 06 000 9933	20.15			09 06 032 2903	00.10	09 06 048 0521	00.10
09 06 000 9908	20.02	09 06 000 9933	20.18			09 06 032 2903	03.28	09 06 048 0521	00.11
09 06 000 9908	20.03	09 06 000 9936	03.24			09 06 032 2905	00.10	09 06 048 0521	20.03
09 06 000 9908	20.14	09 06 000 9936	20.02	09 06 001 9902	20.33	09 06 032 2905	00.11	09 06 048 0521	20.20
09 06 000 9908	20.18	09 06 000 9937	03.24	09 06 001 9903	20.33	09 06 032 2905	03.28	09 06 048 0521	20.21
09 06 000 9908	20.24	09 06 000 9937	20.02	09 06 001 9904	20.33	09 06 032 2941	03.28	09 06 048 0521	20.22
09 06 000 9908	20.25	09 06 000 9939	03.33	09 06 001 9905	20.23			09 06 048 0522	00.09
09 06 000 9909	00.11	09 06 000 9950	00.15	09 06 001 9905	20.28	09 06 045 2871	03.39	09 06 048 0522	00.10
09 06 000 9909	20.02	09 06 000 9955	00.11	09 06 001 9906	20.31	09 06 045 2875	03.39	09 06 048 0522	00.11
09 06 000 9909	20.03	09 06 000 9955	20.02	09 06 001 9909	20.02			09 06 048 0522	20.03
09 06 000 9909	20.14	09 06 000 9957	00.09	09 06 001 9909	20.03			09 06 048 0522	20.21
09 06 000 9909	20.15	09 06 000 9957	00.10	09 06 001 9909	20.24	09 06 048 0401	00.10	09 06 048 0522	20.22
09 06 000 9909	20.18	09 06 000 9957	00.11	09 06 001 9909	20.25	09 06 048 0401	00.11	09 06 048 2903	00.10
09 06 000 9909	20.24	09 06 000 9957	03.25	09 06 001 9918	00.15	09 06 048 0401	20.02	09 06 048 2903	03.28
09 06 000 9909	20.25	09 06 000 9957	20.02	09 06 001 9919	00.15	09 06 048 0401	20.10	09 06 048 2905	00.10
09 06 000 9910	00.11	09 06 000 9957	20.19	09 06 001 9934	20.03	09 06 048 0401	20.11	09 06 048 2905	00.11
09 06 000 9910	20.02	09 06 000 9958	20.19	09 06 001 9934	20.24	09 06 048 0402	00.10	09 06 048 2905	03.28
09 06 000 9910	20.03	09 06 000 9961	20.17	09 06 001 9935	20.03	09 06 048 0402	00.11	09 06 048 2906	00.10
09 06 000 9910	20.14	09 06 000 9966	20.02	09 06 001 9935	20.24	09 06 048 0402	20.02	09 06 048 2906	03.29
09 06 000 9910	20.15	09 06 000 9966	20.03	09 06 001 9939	20.19	09 06 048 0402	20.10	09 06 048 2963	03.28
09 06 000 9910	20.18	09 06 000 9966	20.14	09 06 001 9950	00.16	09 06 048 0402	20.11	09 06 048 2981	00.11
09 06 000 9910	20.24	09 06 000 9966	20.18	09 06 001 9951	00.16	09 06 048 2905	03.21	09 06 048 2981	03.30
09 06 000 9910	20.25	09 06 000 9966	20.24	09 06 001 9952	00.16	09 06 048 0501	00.10		
09 06 000 9911	20.19	09 06 000 9967	20.02	09 06 001 9953	00.16	09 06 048 0501	00.11		
09 06 000 9912	00.10	09 06 000 9967	20.03	09 06 001 9960	00.16	09 06 048 0501	20.02		
09 06 000 9912	03.13	09 06 000 9967	20.14	09 06 001 9961	00.16	09 06 048 0501	20.10	09 06 064 3302	03.36
09 06 000 9912	03.35	09 06 000 9967	20.18	09 06 001 9962	00.16	09 06 048 0501	20.11		
09 06 000 9912	20.15	09 06 000 9967	20.24	09 06 001 9963	00.16	09 06 048 0503	00.09		
09 06 000 9912	20.18	09 06 000 9968	00.09	09 06 001 9964	00.11	09 06 048 0503	00.10	09 06 109 3401	03.37
09 06 000 9913	00.11	09 06 000 9968	00.10	09 06 001 9964	03.29	09 06 048 0503	00.11		
09 06 000 9913	20.02	09 06 000 9968	00.11	09 06 001 9964	20.03	09 06 048 0503	20.02		
09 06 000 9913	20.14	09 06 000 9968	20.03	09 06 001 9974	20.06	09 06 048 0503	20.12	09 06 115 2911	04.11
09 06 000 9914	20.02	09 06 000 9968	20.19	09 06 001 9974	20.08	09 06 048 0503	20.13	09 06 115 2911 222	04.11
09 06 000 9914	20.15	09 06 000 9975	03.35	09 06 001 9974	20.20	09 06 048 0503	20.14	09 06 115 2921	04.11
09 06 000 9915	20.02	09 06 000 9984	20.23	09 06 001 9974	20.27	09 06 048 0503	20.15	09 06 115 2932	04.11
09 06 000 9915	20.15	09 06 000 9985	20.23	09 06 001 9985	20.23	09 06 048 0504	00.09	09 06 115 2932 222	04.11
09 06 000 9917	20.02	09 06 000 9986	20.03	09 06 001 9986	20.11	09 06 048 0504	00.10	09 06 115 2991	04.11

List of part numbers



Part No.	Page	Part No.	Page	Part No.	Page	Part No.	Page	Part No.	Page
09 06 116 2511	04.16	09 06 215 2890	04.14	09 06 248 2821	03.33	09 06 800 9944	20.03	09 06 901 9924	20.25
		09 06 215 2891	04.14	09 06 248 2821 222	03.33	09 06 800 9946	20.31	09 06 901 9924	20.31
		09 06 215 2892	04.14	09 06 248 2823	03.33	09 06 800 9948	20.31	09 06 901 9925	00.11
09 06 121 6981	04.24	09 06 215 2892 222	04.14	09 06 248 2832	03.34	09 06 800 9950	20.30	09 06 901 9925	20.03
				09 06 248 2832 222	03.34	09 06 800 9951	20.30	09 06 901 9925	20.25
				09 06 248 2833	03.21	09 06 800 9952	20.31	09 06 901 9925	20.31
09 06 131 6922	04.22	09 06 216 2411	04.16	09 06 248 2833	03.34	09 06 800 9953	20.30	09 06 901 9934	20.03
09 06 131 6924	04.22			09 06 248 2833 222	03.34	09 06 800 9955	20.30	09 06 901 9934	20.29
				09 06 248 2834	03.34	09 06 800 9958	20.30	09 06 901 9935	20.03
		09 06 221 6883	04.25	09 06 248 2835	03.32	09 06 800 9958	20.31	09 06 901 9935	20.29
				09 06 248 2848	03.32	09 06 800 9960	20.30	09 06 901 9985	20.28
09 06 132 2901	03.27			09 06 248 3201	03.31				
09 06 132 2921	03.27	09 06 231 2821	04.23	09 06 248 3201	20.21	09 06 848 0550	00.11	09 06 948 0521	20.03
09 06 132 2931	03.27	09 06 231 2821 222	04.23	09 06 248 3201 222	03.31	09 06 848 0550	20.03	09 06 948 0521	20.20
09 06 132 6901	03.27	09 06 231 2822	04.23			09 06 848 0550	20.21	09 06 948 0521	20.21
09 06 132 6901 222	03.27	09 06 231 2881	04.23	09 06 248 6821	03.33	09 06 848 0550	20.30	09 06 948 0521	20.27
09 06 132 6921	03.27	09 06 231 2881	20.21	09 06 248 6821 222	03.33	09 06 848 0551	00.11	09 06 948 0521	20.27
09 06 132 6931	03.27	09 06 231 2881 222	04.23	09 06 248 6823	03.33	09 06 848 0551	20.03	09 06 948 0522	20.03
09 06 132 6931 222	03.27			09 06 248 6826	03.21	09 06 848 0551	20.21	09 06 948 0522	20.21
09 06 132 7901	03.27	09 06 231 6821	04.23	09 06 248 6826	03.35	09 06 848 0551	20.21	09 06 948 0522	20.27
09 06 132 7921	03.27	09 06 231 6822	04.23	09 06 248 6832	03.34				
09 06 132 7931	03.27	09 06 231 6822 222	04.23	09 06 248 6833	03.34				
				09 06 248 6833 222	03.34	09 06 900 9907	20.03		
09 06 145 2971	03.38	09 06 232 2821	03.33	09 06 248 6834	03.34	09 06 900 9907	20.29	09 18 064 7001	01.14
		09 06 232 2823	03.33	09 06 248 6834 222	03.34	09 06 900 9908	20.03	09 18 064 7001	01.26
		09 06 232 2831	03.33	09 06 248 6835	03.32	09 06 900 9908	20.29	09 18 064 7004	01.14
09 06 148 2901	03.27	09 06 232 2832	03.34	09 06 248 6835 222	03.32	09 06 900 9909	20.03	09 18 064 7004	01.26
09 06 148 2901 222	03.27	09 06 232 2832 222	03.34	09 06 248 6836	03.35	09 06 900 9909	20.29	09 18 064 7005	01.14
09 06 148 2921	03.27	09 06 232 2835	03.32	09 06 248 6837	03.34	09 06 900 9910	20.03	09 18 064 7005	01.26
09 06 148 2925	03.27	09 06 232 2843	03.33	09 06 248 6848	03.32	09 06 900 9910	20.29	09 18 064 7006	01.14
09 06 148 6901	03.27	09 06 232 2845	03.32	09 06 248 7821	03.33	09 06 900 9966	20.03	09 18 064 7006	01.26
09 06 148 6901	03.21	09 06 232 2848	03.32	09 06 248 7823	03.33	09 06 900 9966	20.29	09 18 064 7006	01.26
09 06 148 6901 222	03.27	09 06 232 2894	03.34	09 06 248 7832	03.34	09 06 900 9967	20.03	09 18 064 7007	01.14
09 06 148 6921	03.27			09 06 248 7832	03.34	09 06 900 9967	20.29	09 18 064 7007	01.26
09 06 148 6925	03.27	09 06 232 6821	03.33	09 06 248 7833	03.34	09 06 900 9967	20.29	09 18 064 7008	01.14
09 06 148 6925 222	03.27	09 06 232 6823	03.33	09 06 248 7835	03.32	09 06 900 9984	20.28	09 18 064 7008	01.26
09 06 148 6951	03.27	09 06 232 6826	03.35			09 06 900 9985	20.28	09 18 064 7010	01.14
		09 06 232 6831	03.33	09 06 331 6924	04.22	09 06 900 9986	20.03	09 18 064 7010	01.26
09 06 148 7901	03.27	09 06 232 6832	03.34	09 06 332 6931	03.27	09 06 900 9986	20.27	09 18 064 7011	01.14
		09 06 232 6833	03.34			09 06 900 9987	20.03	09 18 064 7011	01.26
		09 06 232 6834	03.34			09 06 900 9987	20.27		
09 06 203 2811	04.17	09 06 232 6835	03.32	09 06 332 7901	03.27	09 06 900 9988	20.03		
09 06 203 2911	04.17	09 06 232 6836	03.35			09 06 900 9988	20.27	09 22 116 6921	01.16
		09 06 232 6843	03.33			09 06 900 9988	20.27	09 22 116 6931	01.16
		09 06 232 6843 222	03.33	09 06 348 2951	03.27	09 06 900 9995	20.29	09 22 116 7931	01.16
09 06 209 3201	03.37	09 06 232 6845	03.32			09 06 900 9995	20.29		
		09 06 232 6846	03.35	09 06 348 6901	03.27	09 06 900 9996	00.11		
		09 06 232 6848	03.32	09 06 348 6901 222	03.27	09 06 900 9996	20.03		
09 06 215 2811	04.12	09 06 232 6858	03.32	09 06 348 6921	03.27	09 06 900 9996	20.29	09 22 132 2921	01.16
09 06 215 2812	04.14	09 06 232 6892	03.34	09 06 348 6951	03.27	09 06 900 9996	20.31	09 22 132 2922	01.16
09 06 215 2821	04.14	09 06 232 6893	03.34			09 06 900 9997	00.11		
09 06 215 2821 222	04.14	09 06 232 6894	03.34	09 06 348 7951	03.27	09 06 900 9997	20.03	09 22 132 6919	01.16
09 06 215 2831	04.14	09 06 232 6897	03.34			09 06 900 9997	20.29	09 22 132 6920	01.16
09 06 215 2841	04.14			09 06 721 6883	04.25	09 06 900 9997	20.31	09 22 132 6921	01.16
09 06 215 2854	04.15	09 06 232 7821	03.33					09 22 132 6921 222	01.16
09 06 215 2854 222	04.15	09 06 232 7823	03.33			09 06 901 9909	20.03	09 22 132 6922	01.16
09 06 215 2871	04.12	09 06 232 7831	03.33	09 06 800 9943	00.11	09 06 901 9909	20.29	09 22 132 6951	01.16
09 06 215 2871	20.21	09 06 232 7843	03.33	09 06 800 9943	20.03	09 06 901 9924	00.11	09 22 132 7921	01.16
09 06 215 2871 222	04.12	09 06 232 7894	03.34	09 06 800 9944	00.11	09 06 901 9924	20.03	09 22 132 7922	01.16

Part numbers

List of part numbers



Part No.	Page	Part No.	Page	Part No.	Page	Part No.	Page	Part No.	Page
09 22 232 6421	01.17	09 23 148 2921	01.28	09 23 448 6824	01.30	09 26 024 3201	03.42	09 28 148 7902	01.54
09 22 232 6821	01.17	09 23 148 2922	01.28	09 23 448 6825	01.30	09 26 024 3411	03.40	09 28 148 7903	01.54
09 22 232 6824	01.17	09 23 148 6919	01.28					09 28 148 7904	01.54
09 22 232 6825	01.17	09 23 148 6920	01.28					09 28 148 7907	01.54
09 22 232 6825 222	01.17	09 23 148 6921	01.28					09 28 148 7985	01.54
09 22 232 6829	01.17	09 23 148 6921 222	01.28	09 24 120 6571	01.18	09 27 132 6577	01.53		
09 22 232 6841	01.17	09 23 148 6922	01.28	09 24 120 6579	01.18	09 27 132 6902	01.53	09 28 248 6801	01.56
09 22 232 6850	01.17	09 23 148 6951	01.28	09 24 120 6919	01.18	09 27 132 6903	01.53		
09 22 332 6919	01.16	09 23 148 7919	01.28	09 24 120 6921	01.18	09 27 132 6903 222	01.53		
09 22 332 6921	01.16	09 23 148 7921	01.28	09 24 120 6922	01.18	09 27 132 6904	01.53	09 28 348 6902	01.54
		09 23 148 7922	01.28			09 27 132 6907	01.53	09 28 348 6903	01.54
09 22 432 6824	01.17	09 23 148 7951	01.28	09 24 220 6414	01.19	09 27 132 6954	01.53	09 28 348 7902	01.54
09 22 432 6825	01.17			09 24 220 6824	01.19	09 27 132 7902	01.53		
		09 23 232 6823	01.30	09 24 220 6825	01.19	09 27 132 7903	01.53	09 28 448 6801	01.56
		09 23 232 6824	01.30	09 24 220 6841	01.19	09 27 132 7907	01.53		
09 23 000 9950	01.58	09 23 232 6825	01.30	09 24 220 6850	01.19				
09 23 000 9951	01.58	09 23 232 6829	01.30	09 24 220 6870	01.19	09 27 232 6801	01.56	09 72 164 6577	01.52
09 23 000 9952	01.58	09 23 232 6841	01.30					09 72 164 6902	01.52
09 23 000 9953	01.58	09 23 232 6850	01.30					09 72 164 6903	01.52
09 23 000 9954	01.58	09 23 232 7825	01.30	09 25 030 0501	20.08			09 72 164 6904	01.52
09 23 000 9955	01.58			09 25 030 0501	20.02			09 72 164 6904 222	01.52
09 23 000 9956	01.58							09 72 164 6907	01.52
09 23 000 9957	01.58	09 23 248 2824	01.30	09 25 030 3214	01.34	09 28 132 2902	01.54	09 72 164 6909	01.52
09 23 000 9958	01.58	09 23 248 2825	01.30			09 28 132 2907	01.54	09 72 164 6954	01.52
09 23 000 9959	01.58	09 23 248 2850	01.30					09 72 164 6974	01.52
09 23 000 9960	01.58	09 23 248 6421	01.30	09 25 120 6921	01.32	09 28 132 6519	01.54	09 72 164 6985	01.52
09 23 000 9961	01.58	09 23 248 6821	01.30	09 25 120 6922	01.32	09 28 132 6520	01.54	09 72 164 6995	01.52
09 23 000 9962	01.58	09 23 248 6824	01.30			09 28 132 6902	01.54	09 72 164 7902	01.52
09 23 000 9963	01.58	09 23 248 6824	01.62	09 25 130 6571	01.32	09 28 132 6903	01.54	09 72 164 7903	01.52
09 23 000 9964	01.58	09 23 248 6824 222	01.30	09 25 130 6572	01.32	09 28 132 6904	01.54	09 72 164 7907	01.52
09 23 000 9965	01.58	09 23 248 6825	01.30	09 25 130 6579	01.32	09 28 132 6907	01.54		
09 23 000 9966	01.58	09 23 248 6825 222	01.30	09 25 130 6590	01.32	09 28 132 6985	01.54		
09 23 000 9967	01.58	09 23 248 6829	01.30	09 25 130 6919	01.32	09 28 132 7902	01.54		
09 23 000 9968	01.58	09 23 248 6841	01.30	09 25 130 6921	01.32	09 28 132 7903	01.54	09 72 264 6801	01.56
09 23 000 9969	01.58	09 23 248 6850	01.30	09 25 130 6922	01.32	09 28 132 7907	01.54		
		09 23 248 6850 222	01.30					09 72 364 6902	01.52
09 23 048 0501	20.02	09 23 248 6866	01.30						
09 23 048 0501	20.08	09 23 248 6866	01.62	09 25 220 6824	01.34	09 28 148 2902	01.54		
				09 25 220 6825	01.34	09 28 148 2903	01.54	09 72 464 6801	01.56
09 23 048 3214	01.27					09 28 148 2907	01.54		
09 23 048 3217	01.27	09 23 316 6931	01.28						
				09 25 230 6414	01.34	09 28 148 5531	01.57		
09 23 116 2931	01.28	09 23 332 6919	01.28	09 25 230 6824	01.34	09 28 148 6519	01.54	09 73 124 6902	01.44
09 23 116 6931	01.28	09 23 332 6921	01.28	09 25 230 6825	01.34	09 28 148 6520	01.54	09 73 124 6903	01.44
		09 23 332 7921	01.28	09 25 230 6841	01.34	09 28 148 6521	01.54	09 73 124 6904	01.44
09 23 132 2921	01.28			09 25 230 6850	01.34	09 28 148 6532	01.57	09 73 124 6907	01.44
09 23 132 2922	01.28			09 25 230 6870	01.34	09 28 148 6532	01.62	09 73 124 6985	01.44
09 23 132 6919	01.28	09 23 348 6919	01.28			09 28 148 6577	01.54		
09 23 132 6920	01.28	09 23 348 6921	01.28			09 28 148 6902	01.54		
09 23 132 6921	01.28	09 23 348 6951	01.28	09 26 000 9901	03.42	09 28 148 6903	01.54	09 73 142 6902	01.44
09 23 132 6922	01.28	09 23 348 7921	01.28			09 28 148 6903 222	01.54	09 73 142 6903	01.44
						09 28 148 6904	01.54	09 73 142 6904	01.44
09 23 132 7921	01.28			09 26 024 0401	03.42	09 28 148 6904 222	01.54	09 73 142 6907	01.44
09 23 132 7922	01.28	09 23 432 6824	01.30			09 28 148 6907	01.54	09 73 142 6974	01.44
				09 26 024 2981	03.41	09 28 148 6974	01.54	09 73 142 6985	01.44
						09 28 148 6985	01.54		

Part numbers

List of part numbers



Part No.	Page	Part No.	Page	Part No.	Page	Part No.	Page	Part No.	Page
09 73 160 6902	01.44	09 73 196 7902	01.46	09 73 796 6801	01.49	09 99 000 0114	01.14	09 99 000 0270	30.06
09 73 160 6903	01.44	09 73 196 7903	01.46			09 99 000 0114	01.26	09 99 000 0271	30.06
09 73 160 6904	01.44	09 73 196 7904	01.46			09 99 000 0116	01.14	09 99 000 0272	30.06
09 73 160 6907	01.44	09 73 196 7907	01.46			09 99 000 0116	01.26	09 99 000 0274	30.06
09 73 160 6974	01.44	09 73 196 7974	01.46	09 79 164 2950	01.48	09 99 000 0119	30.16	09 99 000 0275	30.06
09 73 160 6985	01.44			09 79 164 6903	01.50	09 99 000 0120	30.16	09 99 000 0276	30.06
		09 73 232 2801	01.49	09 79 164 6907	01.50	09 99 000 0133	00.16	09 99 000 0277	30.06
		09 73 232 6801	01.49			09 99 000 0150	01.14	09 99 000 0278	30.10
09 73 164 2902	01.46	09 73 232 6811	01.49	09 79 196 2950	01.48	09 99 000 0150	01.26	09 99 000 0279	30.11
09 73 164 2903	01.46	09 73 232 7801	01.49	09 79 196 2961	01.48	09 99 000 0158	30.17	09 99 000 0282	30.11
09 73 164 2904	01.46			09 79 196 6902	01.50	09 99 000 0172	03.39	09 99 000 0328	01.39
09 73 164 2907	01.46			09 79 196 6903	01.50	09 99 000 0174	01.39	09 99 000 0328	04.24
		09 73 264 2801	01.49	09 79 196 6907	01.50	09 99 000 0174	04.25	09 99 000 0620	30.16
09 73 164 6577	01.46	09 73 264 6801	01.49			09 99 000 0179	01.14	09 99 000 0621	30.16
09 73 164 6902	01.46	09 73 264 6804	01.49	09 79 264 6801	01.51	09 99 000 0179	01.26	09 99 000 0622	30.16
09 73 164 6903	01.46	09 73 264 7801	01.49	09 79 264 7801	01.51	09 99 000 0180	01.14	09 99 000 0623	30.16
09 73 164 6904	01.46					09 99 000 0180	01.26	09 99 000 0627	30.16
09 73 164 6907	01.46	09 73 296 2801	01.49	09 79 296 6801	01.51	09 99 000 0181	30.06	09 99 000 0628	30.17
09 73 164 6947	01.46	09 73 296 6801	01.49	09 79 296 7801	01.51	09 99 000 0183	30.06	09 99 000 0629	30.16
09 73 164 6974	01.46	09 73 296 6801	01.60			09 99 000 0185	30.05	09 99 000 0630	30.16
09 73 164 6985	01.46	09 73 296 6801	01.61	09 79 364 6903	01.50	09 99 000 0191	30.16	09 99 000 0631	30.16
		09 73 296 6801	02.17			09 99 000 0194	01.39	09 99 000 0632	30.16
		09 73 296 6801 222	01.49	09 79 396 6903	01.50	09 99 000 0196	01.39		
		09 73 296 6804	01.49			09 99 000 0197	30.06		
09 73 178 6902	01.44	09 73 296 6804	01.49	09 79 464 6801	01.51	09 99 000 0197	30.07	20 10 001 4211	01.36
09 73 178 6903	01.44	09 73 296 7801	01.49	09 79 496 6801	01.51	09 99 000 0197	30.08	20 10 001 4221	01.36
09 73 178 6904	01.44					09 99 000 0198	30.07		
09 73 178 6907	01.44					09 99 000 0198	30.08		
09 73 178 6974	01.44	09 73 364 2902	01.46	09 89 040 0000	30.13	09 99 000 0200	30.07	20 10 125 4212	01.36
09 73 178 6985	01.44	09 73 364 6902	01.46	09 89 040 3000	30.14	09 99 000 0200	30.08	20 10 125 4222	01.36
		09 73 364 6903	01.46			09 99 000 0201	30.11		
						09 99 000 0218	30.07		
						09 99 000 0218	30.08		
						09 99 000 0219	30.07		
09 73 196 2577	01.46			09 89 040 0000	30.13	09 99 000 0219	30.08	20 10 230 4211	01.36
09 73 196 2902	01.46	09 73 396 6902	01.46			09 99 000 0220	30.07	20 10 230 4221	01.36
09 73 196 2903	01.46	09 73 396 6903	01.46			09 99 000 0220	30.08		
09 73 196 2904	01.46					09 99 000 0221	30.06		
09 73 196 2907	01.46					09 99 000 0221	30.07		
		09 73 464 2804	01.49			09 99 000 0221	30.07		
		09 73 464 2804	01.49	09 98 000 3004	30.19	09 99 000 0228	30.06		
09 73 196 5531	01.57	09 73 464 6801	01.49	09 98 000 3005	30.19	09 99 000 0229	30.06		
09 73 196 5531	01.62	09 73 464 6804	01.49	09 98 000 3006	30.19	09 99 000 0239	30.07	61 03 000 0042	20.31
		09 73 464 7801	01.49	09 98 000 3007	30.19	09 99 000 0240	30.07	61 03 000 0044	20.31
09 73 196 6519	01.46			09 98 000 3008	30.19	09 99 000 0241	30.07	61 03 000 0141	20.31
09 73 196 6520	01.46			09 98 000 3008	30.19	09 99 000 0242	00.15	61 03 000 0143	20.31
09 73 196 6521	01.46			09 98 000 3009	30.19	09 99 000 0243	01.39		
09 73 196 6577	01.46	09 73 496 2804	01.49	09 98 000 3012	30.19	09 99 000 0244	30.11		
09 73 196 6902	01.46	09 73 496 6801	01.49	09 98 000 5000	30.18	09 99 000 0246	30.17		
09 73 196 6903	01.46	09 73 496 6804	01.49			09 99 000 0247	30.16		
09 73 196 6903	01.61	09 73 496 7801	01.49			09 99 000 0248	30.16		
09 73 196 6903 222	01.46					09 99 000 0248	30.16		
09 73 196 6904	01.46					09 99 000 0249	30.17		
09 73 196 6904	01.61					09 99 000 0250	30.17		
09 73 196 6907	01.46	09 73 664 6947	01.46	09 99 000 0038	00.16	09 99 000 0251	30.17		
09 73 196 6953	01.46			09 99 000 0087	30.16	09 99 000 0252	30.17		
09 73 196 6954	01.46			09 99 000 0088	30.16	09 99 000 0255	30.11		
09 73 196 6974	01.46	09 73 696 6902	01.46	09 99 000 0100	30.16	09 99 000 0256	30.05		
09 73 196 6985	01.46	09 73 696 6904	01.46	09 99 000 0101	30.16	09 99 000 0261	30.11		
09 73 196 6995	01.46	09 73 696 6947	01.46	09 99 000 0103	00.15	09 99 000 0269	30.06		

Please send me further information:

DVD HARKIS® basic

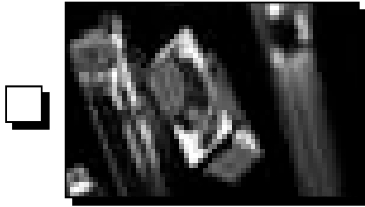

Interface Connectors

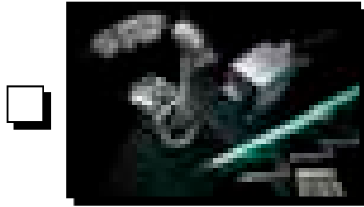

Device Connectivity



Industrial Connectors Han®

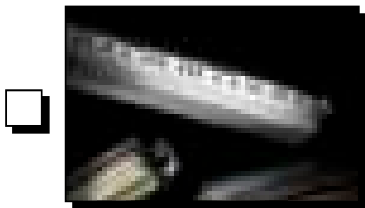

**Connectors
DIN 41612**

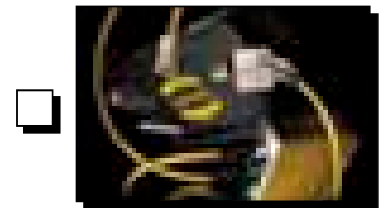

**Intelligent Network
Solutions**

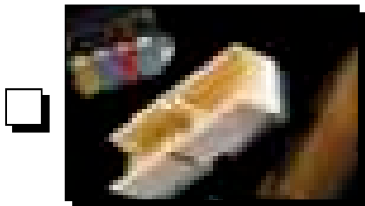

**Coaxial and Metric
Connectors**

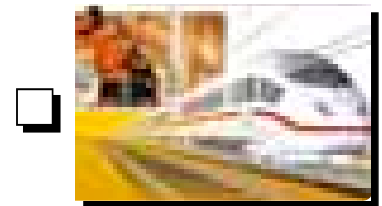

**Application
brochure**



TCA Connectors

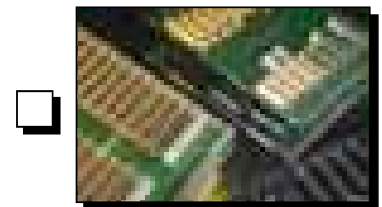

**High Speed
Backplanes**

Sender:

Company: _____

Street: _____

Department: _____

Postcode/Town: _____

Name: _____

Country: _____

Prenome: _____

Phone: _____

Function: _____

Fax: _____

E-Mail: _____

Please send it by post or fax to your local HARTING representatives (see page addresses) or visit us under www.HARTING.com.

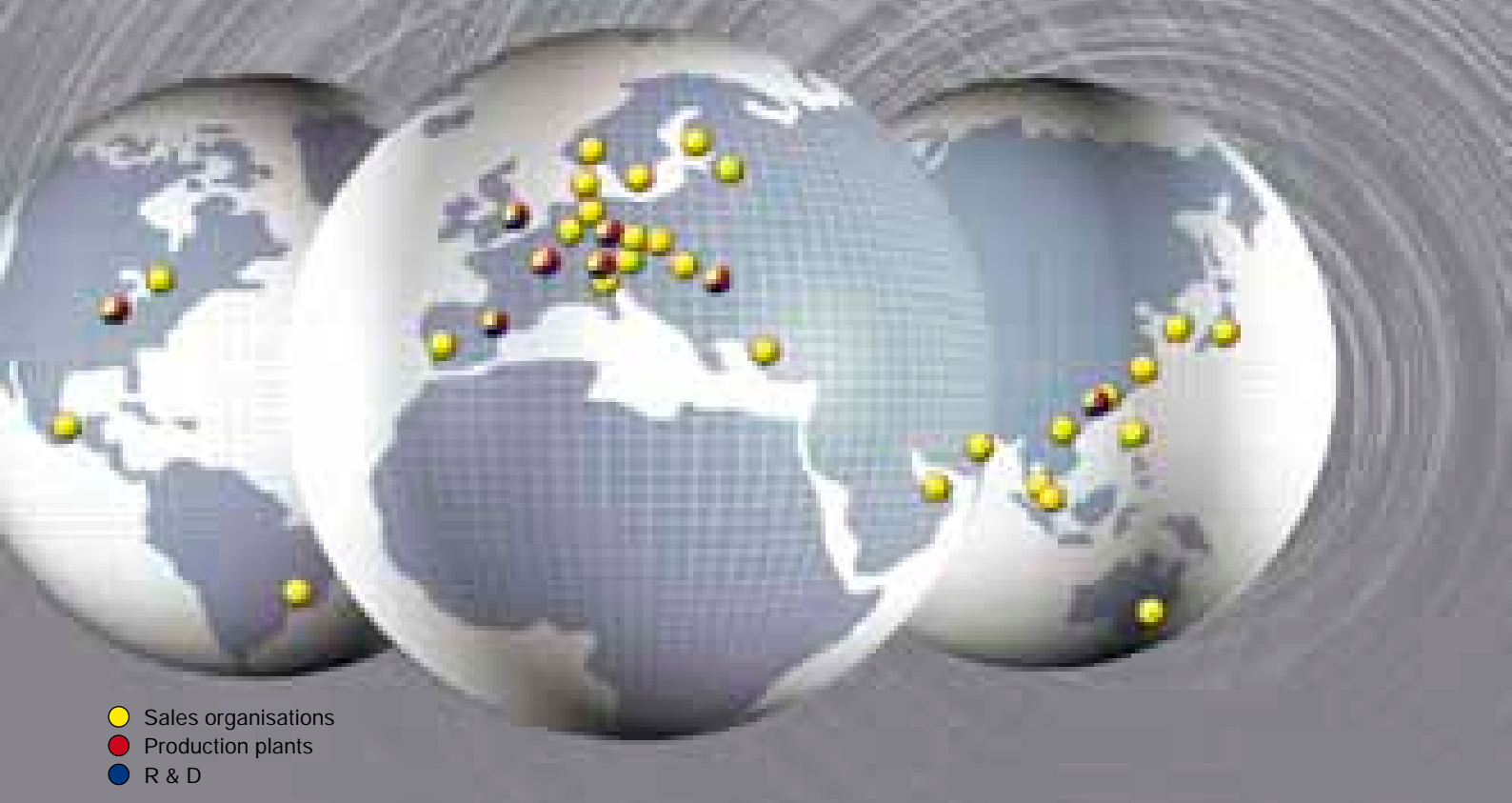

- Sales organisations
- Production plants
- R & D

Sales Network – worldwide



Albania

see Eastern Europe

Argentina

Condelectric S.A.
Hipólito Yrigoyen 2591, 1640 - Martínez
Buenos Aires – Argentina
Phone +54 11 4836 1053
Fax +54 11 4836 1053
comercial@condelectric.com.ar

Armenia

see Eastern Europe

Australia

HARTING Pty Ltd
Suite 11 / 2 Enterprise Drive
Bundoora 3083, AUS-Victoria
Phone +61 3 9466 7088
Fax +61 3 9466 7099
au@HARTING.com
www.HARTING.com.au

Austria

HARTING Ges.m.b.H.
Deutschstraße 19, A-1230 Wien
Phone +431 6162121
Fax +431 6162121-21
at@HARTING.com
www.HARTING.at

Azerbaijan

see Eastern Europe

Bahrain

see United Arab Emirates

Belgium

HARTING N.V./S.A.
Z.3 Doornveld 23, B-1731 Zellik
Phone +32 2 466 0190
Fax +32 2 466 7855
be@HARTING.com
www.HARTING.be

Bosnia and Herzegovina

see Eastern Europe

Brazil

HARTING Ltda.
Rua Major Paladino 128 –
Prédio 11
CEP 05307-000 – São Paulo –
SP – Brasil
Phone +55 11 5035 0073
Fax +55 11 5034 4743
br@HARTING.com
www.HARTING.com.br

Brunei

see Singapore

Bulgaria

see Eastern Europe

Canada

HARTING Canada Inc.
8455 Trans-Canada Hwy., Suite 202
St. Laurent, QC, H4S1Z1, Canada
Tel. 855-659-6653, Fax 855-659-6654
info.ca@HARTING.com
www.HARTING.ca

China

HARTING Sales (Shanghai) Limited
Room 5403, HK New World Tower
300 Huai Hai Road (M.), Luwan District
Shanghai 200021, China
Phone +86 21 6386 2200
Fax +86 21 6386 8636
cn@HARTING.com
www.HARTING.com.cn

Croatia

see Eastern Europe

Czech Republic

HARTING s.r.o.
Mlýnská 2, CZ-160 00 Praha 6
Phone +420 220 380 460
Fax +420 220 380 461
cz@HARTING.com
www.HARTING.cz

Denmark

HARTING ApS
Hjulgagervej 4a
DK - 7100 Vejle
Phone +45 70 25 00 32
Fax +45 75 80 64 99
dk@HARTING.com
www.HARTING.com

Eastern Europe

HARTING Eastern Europe GmbH
Bamberger Straße 7
D-01187 Dresden
Phone +49 351 4361 760
Fax +49 351 436 1770
Eastern.Europe@HARTING.com
www.HARTING.com

Estonia

see Eastern Europe

Finland

HARTING Oy
Teknobulevardi 3-5
FI-01530 Vantaa
Phone +358 207 291 510
Fax +358 207 291 511
fi@HARTING.com
www.HARTING.fi

France

HARTING France
181 avenue des Nations, Paris Nord 2
BP 66058 Tremblay en France
F-95972 Roissy Charles de Gaulle
Cédex
Phone +33 1 4938 3400
Fax +33 1 4863 2306
fr@HARTING.com
www.HARTING.fr

Germany

HARTING Deutschland GmbH & Co. KG
P.O. Box 2451, D-32381 Minden
Simeons carré 1, D-32427 Minden
Phone +49 571 8896 0
Fax +49 571 8896 282
de@HARTING.com
www.HARTING-Deutschland.de

Georgia

see Eastern Europe

Great Britain

HARTING Ltd., Caswell Road
Brackmills Industrial Estate
GB-Northampton, NN4 7PW
Phone +44 1604 827 500
Fax +44 1604 706 777
gb@HARTING.com
www.HARTING.co.uk

Hong Kong

HARTING (HK) Limited
Regional Office Asia Pacific
3512 Metroplaza Tower 1
223 Hing Fong Road
Kwai Fong, N. T., Hong Kong
Phone +852 2423 7338
Fax +852 2480 4378
ap@HARTING.com
www.HARTING.com.hk

Hungary

HARTING Magyarország Kft.
Fehérvári út 89-95, H-1119 Budapest
Phone +36 1 205 34 64
Fax +36 1 205 34 65
hu@HARTING.com
www.HARTING.hu

India

HARTING India Private Limited
No. D, 4th Floor, 'Doshi Towers'
No. 156 Poonamallee High Road
Kilpauk, Chennai 600 010
Tamil Nadu, India
Phone +91 44 435604 15 / 416
Fax +91 44 435604 17
in@HARTING.com
www.HARTING.in

Indonesia

see Malaysia

Israel

COMTEL
Israel Electronic Solutions Ltd.
Bet Hapamon, 20 Hataas st.
P.O.Box 66
Kefar-Saba 44425
Phone +972-9-7677240
Fax +972-9-7677243
sales@comtel.co.il
www.comtel.co.il

Italy

HARTING SpA
Via Dell' Industria 7
I-20090 Vimodrone (Milano)
Phone +39 02 250801
Fax +39 02 2650 597
it@HARTING.com
www.HARTING.it

Japan

HARTING K. K.
Yusen Shin-Yokohama 1 Chome Bldg., 2F
1-7-9, Shin-Yokohama, Kohoku
Yokohama 222-0033 Japan
Phone +81 45 476 3456
Fax +81 45 476 3466
jp@HARTING.com
www.HARTING.co.jp

Jordan

see United Arab Emirates

Kazakhstan

see Eastern Europe

Kirghizia

see Eastern Europe

Korea (South)

HARTING Korea Limited
#308 Yatap Leaders Building
342-1, Yatap-dong, Bundang-gu
Sungnam-City, Kyunggi-do
463-828, Republic of Korea
Phone +82 31 781 4615
Fax +82 31 781 4616
kr@HARTING.com
www.HARTING.co.kr

Kosovo

see Eastern Europe

Kuwait

see United Arab Emirates

Latvia

see Eastern Europe

Lithuania

see Eastern Europe

Macedonia

see Eastern Europe

Malaysia (Office)

HARTING Singapore Pte Ltd
Malaysia Branch
11-02 Menara Amcorp
Jln. Persiaran Barat
46200 PJ, Sel. D. E., Malaysia
Phone +60 3 / 7955 6173
Fax +60 3 / 7955 5126
sg@HARTING.com

Montenegro

see Eastern Europe

Netherlands

HARTING B.V.
Larenweg 44
NL-5234 KA 's-Hertogenbosch
Postbus 3526
NL-5203 DM 's-Hertogenbosch
Phone +31 736 410 404
Fax +31 736 440 699
nl@HARTING.com
www.HARTINGbv.nl

New Zealand

see Australia

Norway

HARTING A/S
Østensjøveien 36, N-0667 Oslo
Phone +47 22 700 555
Fax +47 22 700 570
no@HARTING.com
www.HARTING.no

Oman

see United Arab Emirates

Philippines

see Malaysia

Poland

HARTING Polska Sp. z o. o.
ul. Kamieńskiego 201-219
PL-51-126 Wrocław
Phone +48 71 352 81 71
Fax +48 71 320 74 44
pl@HARTING.com
www.HARTING.pl

Portugal

HARTING Iberia, S. A.
Avda. Josep Tarradellas 20-30 4º 6a
E-08029 Barcelona
Phone +351 219 673 177
Fax +351 219 678 457
es@HARTING.com
www.HARTING.es/pt

Qatar

see United Arab Emirates

Republic of Moldova

see Eastern Europe

Romania

HARTING Romania SCS
Europa Unita str. 21
550018-Sibiu, Romania
Phone +40 369-102 671
Fax +40 369-102 622
ro@HARTING.com
www.HARTING.com

Russia

HARTING ZAO
Maliy Sampsoniyevsky prospect 2A
194044 Saint Petersburg, Russia
Phone +7 812 327 6477
Fax +7 812 327 6478
ru@HARTING.com
www.HARTING.ru

Saudi Arabia

see United Arab Emirates

Serbia

see Eastern Europe

Singapore

HARTING Singapore Pte Ltd.
25 International Business Park
#02-06 German Centre
Singapore 609916
Phone +65 6225 5285
Fax +65 6225 9947
sg@HARTING.com
www.HARTING.sg

Slovakia

HARTING s.r.o.
Sales office Slovakia
J. Simora 5, SK - 940 52 Nové Zámky
Phone +421 356-493 993
Fax +421 356-402 114
sk@HARTING.com
www.HARTING.sk

Slovenia

see Eastern Europe

South Africa

Cabcon Technologies (PTY) Ltd
P.O. Box 13002, Northmead, 1511
Phone +27 1184533258
Fax +27 118454077
cabcon@mweb.co.za

Spain

HARTING Iberia S.A.
Avda. Josep Tarradellas 20-30 4º 6a
E-08029 Barcelona
Phone +34 93 363 84 75
Fax +34 93 419 95 85
es@HARTING.com
www.HARTING.es

Sweden

HARTING AB
Gustavslundsvägen 141 B 4tr
S-167 51 Bromma
Phone +46 8 445 7171
Fax +46 8 445 7170
se@HARTING.com
www.HARTING.se

Switzerland

HARTING AG
Industriestrasse 26
CH-8604 Volketswil
Phone +41 44 908 20 60
Fax +41 44 908 20 69
ch@HARTING.com
www.HARTING.ch

Taiwan

HARTING Taiwan Ltd.
Room 1, 5/F
495 GuangFu South Road
RC-110 Taipei, Taiwan
Phone +886 2 2758 6177
Fax +886 2 2758 7177
tw@HARTING.com
www.HARTING.com.tw

Tajikistan

see Eastern Europe

Thailand

see Malaysia

Turkey

HARTING TURKEI Elektronik Ltd. Şti.
Barbaros Mah. Dereboyu Cad.
Fesleğen Sok.
Uphill Towers, A-1b Kat:8 D:45
34746 Ataşehir, İstanbul
Phone +90 216 688 81 00
Fax +90 216 688 81 01
tr@HARTING.com
www.HARTING.com.tr

Turkmenistan

see Eastern Europe

United Arab Emirates

HARTING Middle East FZ-LLC
Knowledge Village, Block 2A, Office F72
P.O. Box 454372, Dubai
United Arab Emirates
Tel. +971 4 453 9737
Fax +971 4 439 0339
uae@HARTING.com
www.HARTING.ae

Ukraine

see Eastern Europe

USA

HARTING Inc. of North America
1370 Bowes Road
USA-Elgin, Illinois 60123
Phone +1 (877) 741-1500 (toll free)
Fax +1 (866) 278-0307 (Inside Sales)
us@HARTING.com
www.HARTING-USA.com

Uzbekistan

see Eastern Europe

Distributors – worldwide



Farnell:
www.farnell.com

RS Components:
www.rs-components.com

FUTURE Electronics:
www.futureelectronics.com

Other countries and general contact



HARTING Electronics GmbH & Co. KG
P.O. Box 1433
32328 Espelkamp - Germany
Phone +49 5772/47-97200
Fax +49 5772/47-777
electronics@HARTING.com



Pushing Performance

www.HARTING.com



Office: 61 Lerin str.
1680 Sofia, Bulgaria
Call us: 029731195; 9734626
Send us email: office@famousconnections.eu
www.famousconnections.eu